



ELSEVIER

Available online at www.sciencedirect.com

SCIENCE @ DIRECT®

International Journal of Pressure Vessels and Piping 79 (2002) 829–840

INTERNATIONAL JOURNAL OF
Pressure Vessels
and Piping

www.elsevier.com/locate/ijpvp

Determination of flexibility factors in curved pipes with end restraints using a semi-analytic formulation

E.M.M. Fonseca^{a,*}, F.J.M.Q. de Melo^b, C.A.M. Oliveira^b

^aDepartment of Applied Mechanics, Polytechnic Institute of Bragança, Campus De Sta Apolonia Apartado 134, Bragança 5301 857, Portugal

^bDepartment of Mechanical Engineering and Industrial Management, Faculty of Engineering, University of Porto, Porto, Portugal

Received 17 January 2002; revised 30 August 2002; accepted 17 September 2002

Abstract

Piping systems are structural sets used in the chemical industry, conventional or nuclear power plants and fluid transport in general-purpose process equipment. They include curved elements built as parts of toroidal thin-walled structures. The mechanical behaviour of such structural assemblies is of leading importance for satisfactory performance and safety standards of the installations. This paper presents a semi-analytic formulation based on Fourier trigonometric series for solving the pure bending problem in curved pipes. A pipe element is considered as a part of a toroidal shell. A displacement formulation pipe element was developed with Fourier series. The solution of this problem is solved from a system of differential equations using mathematical software. To build-up the solution, a simple but efficient deformation model, from a semi-membrane behaviour, was followed here, given the geometry and thin shell assumption. The flexibility factors are compared with the ASME code for some elbow dimensions adopted from ISO 1127. The stress field distribution was also calculated.

© 2002 Elsevier Science Ltd. All rights reserved.

Keywords: Curved pipe; Pure bending; Flexibility factor; Semi-analytic formulation; Fourier series

1. Introduction

Pipe bends play a very important role in the global piping arrangement, as they not only allow flow direction change, but they also absorb thermal expansions and longitudinal deformations from adjacent tangent parts or other straight pipe elements [1]. Computer codes have been used extensively to expedite calculations of deflections, reactions and stresses both in piping system and pressure vessels. In order to determine such calculations, it is important to know flexibility factor values, where the case of pure bending is one of the most used in design [2]. Many experiments and theories have been presented to demonstrate and explain the flexibility and stresses of a curved pipe compared with elastic beam theory. In this paper we will present the results of flexibility factors using a formulation for a curved pipe subjected to uniform bending moment. We have determined the flexibility factor when the curved pipe was fitted with

thin or thick flanges. Throughout this formulation beam theory combined with the shell membrane equations is assumed.

2. Equation formulations

2.1. Essential assumptions

The deformation field refers to membrane strains and curvature variations.

The following assumptions [3] were considered in the present analysis:

- the curvature radius R is assumed much larger than the section radius r ;
- a semi-membrane deformation model is adopted and neglects the bending stiffness along the longitudinal direction of the toroidal shell but considers the meridional bending resulting from ovalization;
- the shell is thin and inextensible along the meridional direction.

* Corresponding author. Tel.: +351-273-303-157; fax: +351-273-313-051.

E-mail address: efonseca@ipb.pt (E.M.M. Fonseca).

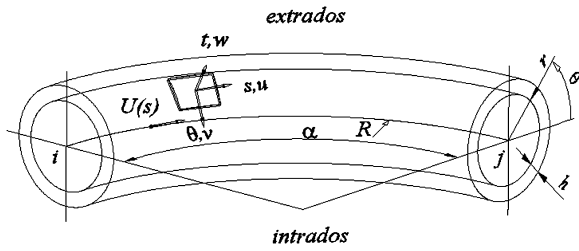

Fig. 1. Geometric parameters for the curved pipe.

Fig. 1 shows the essential parameters defining the pipe bend geometry.

2.2. The displacement field

For the displacement field we have superposed the effect of the rotation with trigonometric terms, for problems by symmetric bending

$$\varphi(x) = \frac{x}{L} \delta\alpha + \sum_{k \geq 1}^{nx} r_k \sin \frac{k\pi x}{L} \text{ (complete set of terms)} \quad (1a)$$

$$\varphi(x) = \frac{x}{L} \delta\alpha + \sum_{k \geq 1}^{nx} r_k \frac{L}{(2k-1)\pi} \times \sin \frac{(2k-1)\pi x}{L} \text{ (with odd terms)} \quad (1b)$$

The displacement field for the curved beam coincident with a central arch is:

$$W(x) = - \int \varphi(x) dx \quad (2)$$

$$U(x) = - \frac{1}{R} \int W(x) dx \quad (3)$$

Here, trigonometric terms for section ovalization are included

$$\sum_{k \geq 1}^{nx} \cos \frac{(2k-1)\pi x}{2L} \times \sum_{i \geq 2}^{n\theta} - \frac{a_{ki}}{i} \sin i\theta \text{ (for } v \text{ displacement)} \quad (4)$$

$$\sum_{k \geq 1}^{nx} \cos \frac{(2k-1)\pi x}{2L} \times \sum_{i \geq 2}^{n\theta} a_{ki} \cos i\theta \text{ (for } w \text{ displacement)} \quad (5)$$

Similar expressions are defined for the transverse section warping displacement field. Thus, expressions for warping u -displacement in transverse sections of the curved pipe either with rigid or thin flanges are:

$$\sum_{k=1}^{nx} \sin \frac{k\pi x}{L} \sum_{i \geq 2}^{n\theta} b_{ki} \cos i\theta \text{ (for rigid flanges)} \quad (6a)$$

$$\sum_{k=1}^{nx} \sin \frac{k\pi x}{2L} \sum_{i \geq 2}^{n\theta} b_{ki} \cos i\theta \text{ (for thin flanges)} \quad (6b)$$

Finally, following the formulation proposed by Thomson [6], the displacement field in a curved pipe resulting from the superposition of displacement shell and the complete Fourier expansion for ovalization and warping terms, is:

$$u = U(x) + (r \cos \theta) \varphi(x) + \sum_{k=1}^{nx} \sin \frac{k\pi x}{L} \times \sum_{i \geq 2}^{n\theta} b_{ki} \cos i\theta, \text{ (for rigid flanges)} \quad (7a)$$

$$u = U(x) + (r \cos \theta) \varphi(x) + \sum_{k=1}^{nx} \sin \frac{k\pi x}{2L} \times \sum_{i \geq 2}^{n\theta} b_{ki} \cos i\theta, \text{ (for thin flanges)} \quad (7b)$$

$$v = -W(x) \sin \theta + \sum_{k \geq 1}^{nx} \sum_{i \geq 2}^{n\theta} - \frac{a_{ki}}{i} \left(\frac{\cos(2k-1)\pi x}{2L} \right) (\sin i\theta) \quad (8)$$

$$w = +W(x) \cos \theta + \sum_{k \geq 1}^{nx} \sum_{i \geq 2}^{n\theta} a_{ki} \left(\cos \frac{(2k-1)\pi x}{2L} \right) (\cos i\theta) \quad (9)$$

Depicting the displacement field in a condensed matrix representation

$$\begin{Bmatrix} u \\ v \\ w \end{Bmatrix} = \begin{bmatrix} \frac{x^3}{6LR} + r \cos \theta \frac{x}{L} & 0 & \{CS_i\} \\ \frac{x^2}{2L} \sin \theta & \{S_i\} & 0 \\ -\frac{x^2}{2L} \cos \theta & \{CS_i\} & 0 \end{bmatrix} \begin{Bmatrix} \delta\alpha \\ r \\ a \\ b \end{Bmatrix} \quad (10)$$

where

$$\{CS_i\} = \sum_{k=1}^{nx} \sin \frac{k\pi x}{L} \sum_{i \geq 2}^{n\theta} b_{ki} \cos i\theta \text{ or}$$

$$\{CS_i\} = \sum_{k=1}^{nx} \sin \frac{k\pi x}{2L} \sum_{i \geq 2}^{n\theta} b_{ki} \cos i\theta,$$

$$\{S_i\} = \sum_{k \geq 1}^{nx} \sum_{i \geq 2}^{n\theta} - \frac{a_{ki}}{i} \left(\frac{\cos(2k-1)\pi x}{2L} \right) (\sin i\theta) \text{ and}$$

$$\{CS_i\} = \sum_{k \geq 1}^{nx} \sum_{i \geq 2}^{n\theta} a_{ki} \left(\cos \frac{(2k-1)\pi x}{2L} \right) (\cos i\theta).$$

2.3. The deformation field

As referred to previously, the deformation model considers that the pipe undergoes a semi-membrane strain field. The strain field is given by the following equations

used by Melo, Flugge and Kitching [3–5]

$$\begin{aligned} \boldsymbol{\varepsilon} &= \begin{Bmatrix} \varepsilon_x \\ \gamma_{x\theta} \\ K_\theta \end{Bmatrix} \\ &= \begin{bmatrix} \frac{\partial}{\partial x} & -\frac{\sin \theta}{R} & \frac{\cos \theta}{R} \\ \frac{1}{r} \frac{\partial}{\partial \theta} + \frac{\sin \theta}{R} & \frac{\partial}{\partial x} & 0 \\ 0 & -\frac{1}{r^2} \frac{\partial}{\partial \theta} & \frac{1}{r^2} \frac{\partial^2}{\partial \theta^2} \end{bmatrix} \begin{Bmatrix} u \\ v \\ w \end{Bmatrix} \end{aligned} \quad (11)$$

where ε_x is the longitudinal membrane strain, $\gamma_{x\theta}$ is the shear strain and K_θ is the meridional curvature from ovalization.

The element stiffness matrix K is calculated from the matrix equation:

$$[K] = \int_{x=0}^{x=L} \int_{\theta=0}^{\theta=2\pi} [B]^T [D] [B] r \, dx \, d\theta \quad (12)$$

The integration of this equation is extended to the pipe surface, where matrix $[B]$ results from:

$$[B] = [L] \times [N] \quad (13)$$

Given that the pipe is inextensible along the meridional direction, no contribution for elastic strain energy arises from such strains. The elasticity matrix D appears with a simpler algebraic definition, having deleted the contribution of off-diagonal terms with a Poisson factor:

$$D = \begin{bmatrix} \frac{Eh}{1-\nu^2} & 0 & 0 \\ 0 & \frac{Eh}{2(1+\nu)} & 0 \\ 0 & 0 & \frac{Eh^3}{12(1-\nu^2)} \end{bmatrix} \quad (14)$$

where E is the elasticity modulus, h is the pipe thickness and ν is Poisson's ratio.

The stress fields are determined by:

$$\boldsymbol{\sigma} = \begin{Bmatrix} N_{xx} \\ N_{x\theta} \\ M_{\theta\theta} \end{Bmatrix} = [D] \begin{Bmatrix} \varepsilon_{xx} \\ \gamma_{x\theta} \\ K_{\theta\theta} \end{Bmatrix} \quad (15)$$

The matrix force–displacement equation for the curved pipe element is

$$[K] \delta_e = \boldsymbol{F} \quad (16)$$

where K is the stiffness matrix and δ_e is a nodal unknown displacement vector.

3. Determination of flexibility factor in curved pipes subjected to uniform bending in the curvature plane

The flexibility coefficient is a parameter that makes possible an accurate calculation for reactions at restraints and attachments in a piping system. For that task, one can use design codes either based on displacement or force methods, having included the flexibility factor as a stiffness reduction parameter for beam elements, whenever curved pipes are involved. In high temperature loading, creep phenomena can be present and a flexibility factor may be used to evaluate the time-dependent variation of the curved pipe bending resistance. The flexibility coefficient is calculated as follows

$$K = \frac{M_C(\delta\alpha)}{M_S(\delta\alpha)} \quad (17)$$

where $M_C(\delta\alpha)$ is a resistant moment in a curved pipe subjected to a bending angle $\delta\alpha$ at the edge and $M_S(\delta\alpha)$ is the corresponding bending moment in a straight pipe, with a length equal to that of the curved one and subjected to the same bending angle at the edge.

The calculation of the bending moment in a circular section can be determined by an integral equation. Considering only semi-membrane behaviour, the bending moment is as follows:

$$M_C = \int_0^{2\pi} \sigma_x h r^2 \cos \theta \, d\theta = \frac{Eh}{1-\nu^2} \int_0^{2\pi} \varepsilon_x r^2 \cos \theta \, d\theta \quad (18)$$

In a thin-walled element only the deformation along x is considered for the calculation of the bending moment.

A similar calculation of the bending moment in the equivalent straight pipe is as follows:

$$M_S = \frac{EI}{(1-\nu^2)} \frac{\delta\alpha}{L} \quad (19)$$

The second moment of area for a thin tubular circular section is represented by:

$$I = \pi r^3 h \quad (20)$$

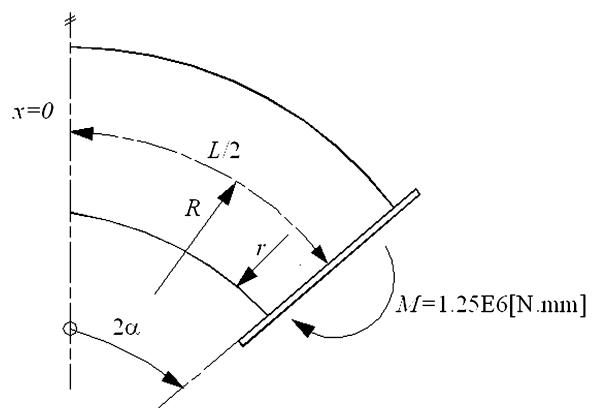

Fig. 2. Geometry of a curved pipe with end restraints.

Table 1
Geometric and material properties for a curved pipe

D (mm)	h (mm)	R (mm)	L (mm)	E (N/mm ²)
340	1.2	1110	826.5	7.36 × 10 ⁴

For the loading case of an imposed moment, the flexibility factors can be determined by the following equation

$$K = \frac{\delta\alpha}{\bar{\delta\alpha}} \tag{21}$$

where

$$\bar{\delta\alpha} = ML(1 - \nu^2)/EI \tag{22}$$

and $\delta\alpha$ in a curved pipe is calculated by Eq. (16).

4. The case study

The studied case is shown in Fig. 2, representing a curved pipe with end restraints, subjected to a uniform bending moment. The geometry and the material properties are in accordance with Table 1, as in Ref. [7]. Only one half of the pipe bend was analysed due to geometric and loading symmetry. The results refer to the transverse section at $x = 0$ in the case of rigid or thin flanges as shown in Fig. 2.

Figs. 3 and 4 show the longitudinal stresses of a curved pipe under pure bending moment, using rigid or thin flanges. Those results obtained with our formulation are compared with the results by Melo and Castro [7], and Wilczek [8]. We have calculated the longitudinal stresses using all terms or only odd terms in the Fourier expansions for the displacements calculation, represented along the semi-section studied (0–180°).

When calculating the stress field for the curved pipes with rigid flanges we may use the formulation by all terms or only odd terms and will obtain the same results. But for the case studied with thin flanges, only the results obtained

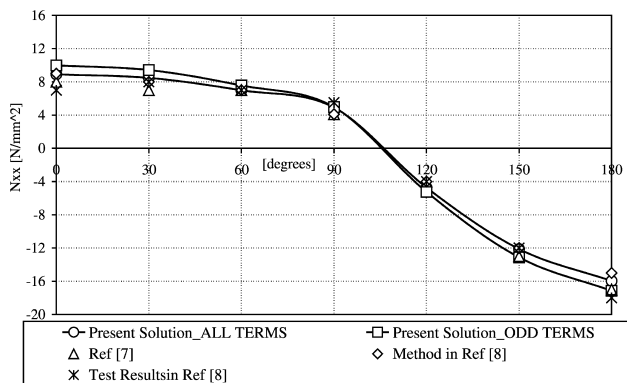

Fig. 3. Longitudinal stresses for a curved pipe with rigid flanges.

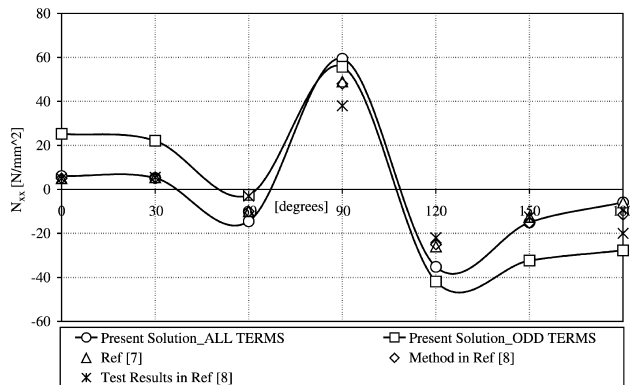

Fig. 4. Longitudinal stresses for a curved pipe with thin flanges.

with all terms are in good agreement with other references, as shown in Fig. 4.

5. Stress analysis for other curved pipe geometry and end restraints

In Table 2, 12 examples of 90° elbows according ISO 1127 are presented. All cases refer to edge prescribed uniform bending moment. In the same way, only one half of the pipe bend was analysed and the results refer to the transverse section at $x = 0$, as shown in Fig. 2.

In Figs. 5 and 6 we show the longitudinal and the meridional stresses for all curved pipes analysed. We have calculated the stresses in all pipes for this loading condition, having used either a complete formulation (all terms) or only odd terms in the Fourier expansions for the displacements evaluation. The top number of terms in the trigonometric expansions was fixed at eight. Next we present the results for a longitudinal membrane and meridional stress in curved pipe bends with end restraints using thick or thin flanges.

Table 2
Geometric parameters for 90° elbows and material proprieties

D (mm)	h (mm)	R (mm)	L (mm)	E (N/mm ²)
21.30	2	31.95	50.19	2.10 × 10 ⁵
33.70	2	50.55	79.40	2.10 × 10 ⁵
60.30	2	90.45	142.08	2.10 × 10 ⁵
101.60	2	152.40	239.39	2.10 × 10 ⁵
323.90	2	485.85	763.17	2.10 × 10 ⁵
406.40	3	609.60	957.56	2.10 × 10 ⁵
508.00	3	762.00	1196.95	2.10 × 10 ⁵
609.60	3	914.40	1436.34	2.10 × 10 ⁵
711.20	4	1066.80	1675.73	2.10 × 10 ⁵
812.80	4	1219.20	1915.11	2.10 × 10 ⁵
914.40	4	1371.60	2154.50	2.10 × 10 ⁵
1016.00	4	1524.00	2393.89	2.10 × 10 ⁵

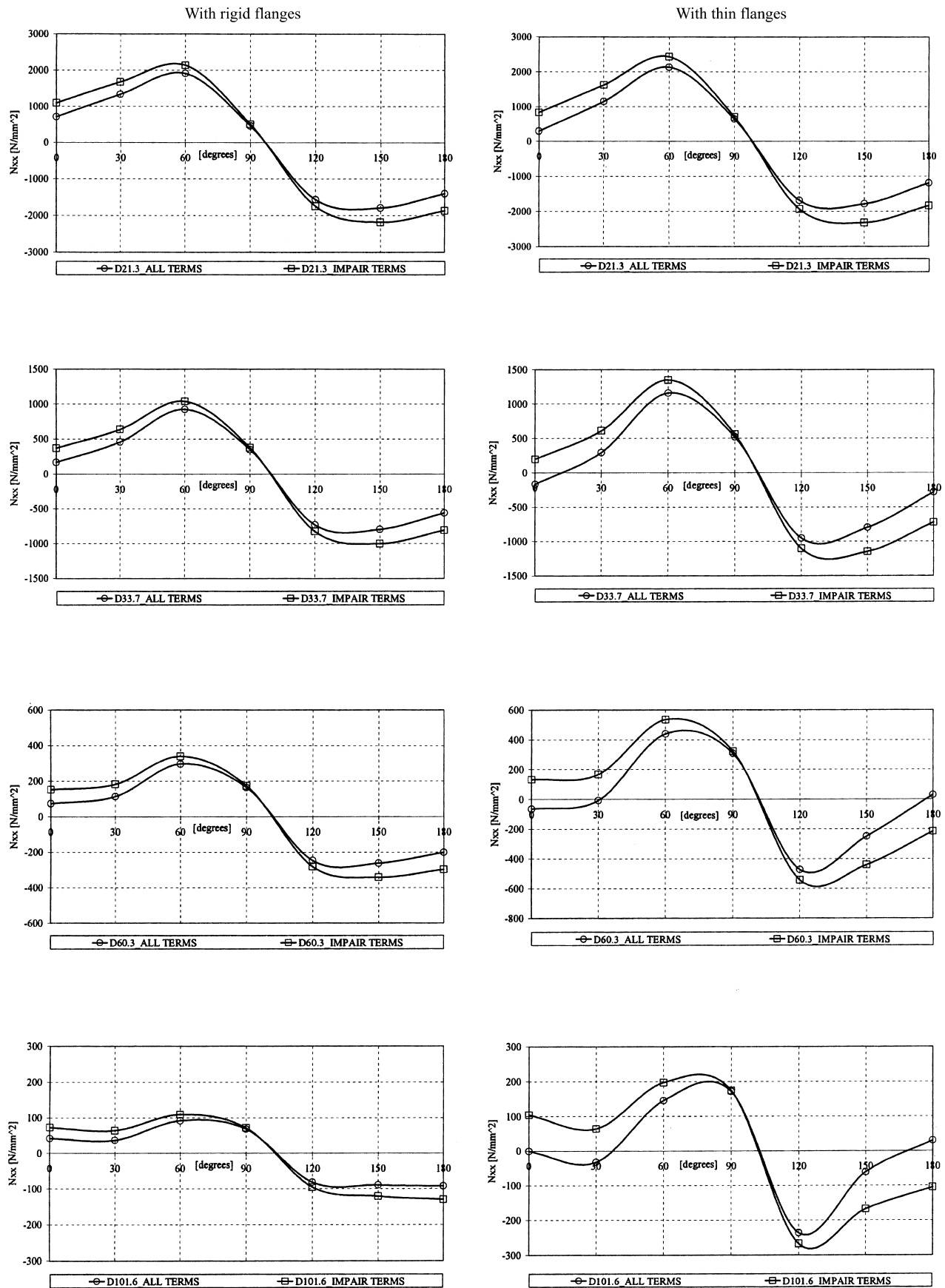

Fig. 5. Longitudinal stresses at section equidistant to edges ($x = 0$).

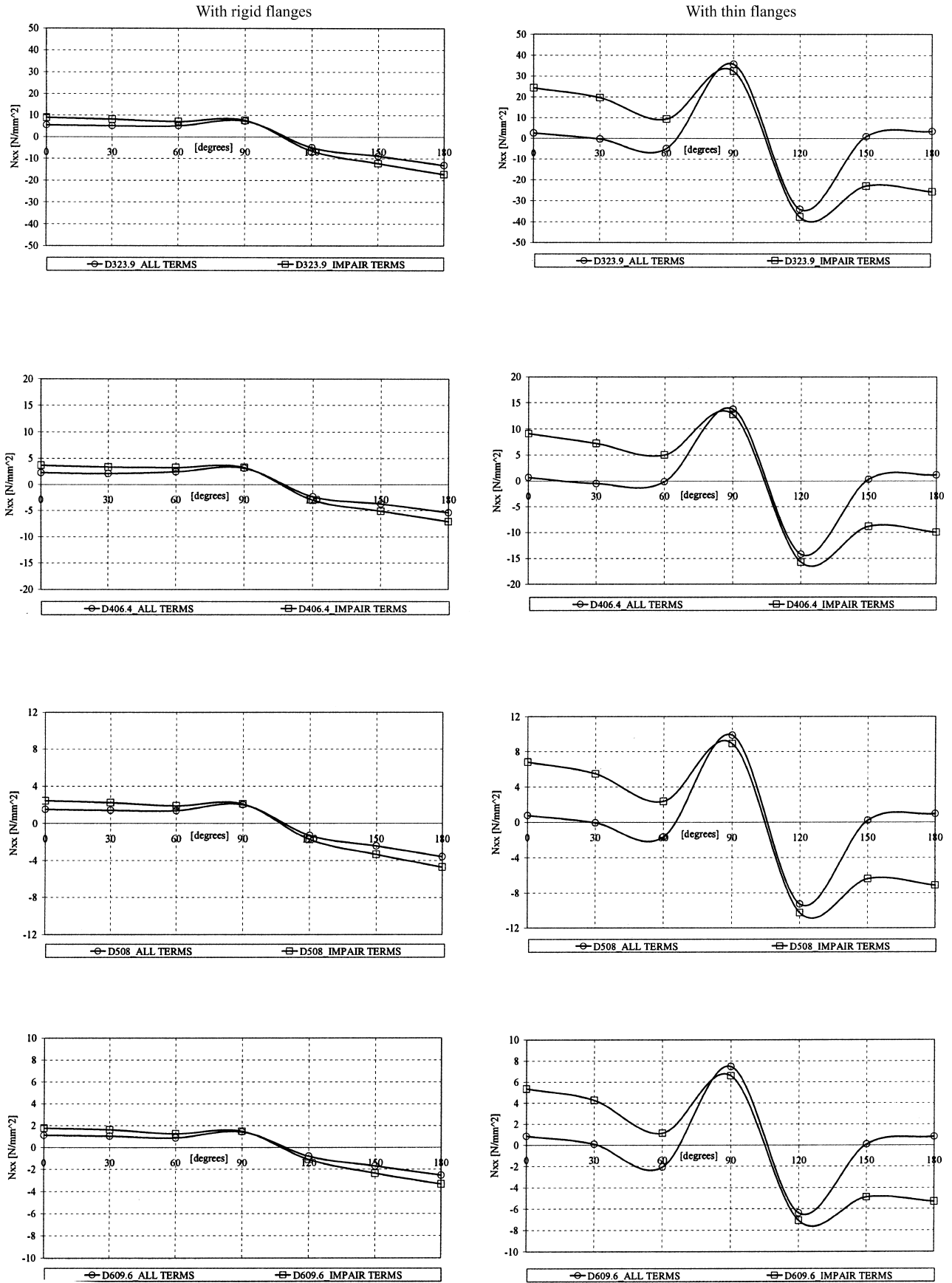

Fig. 5. (continued)

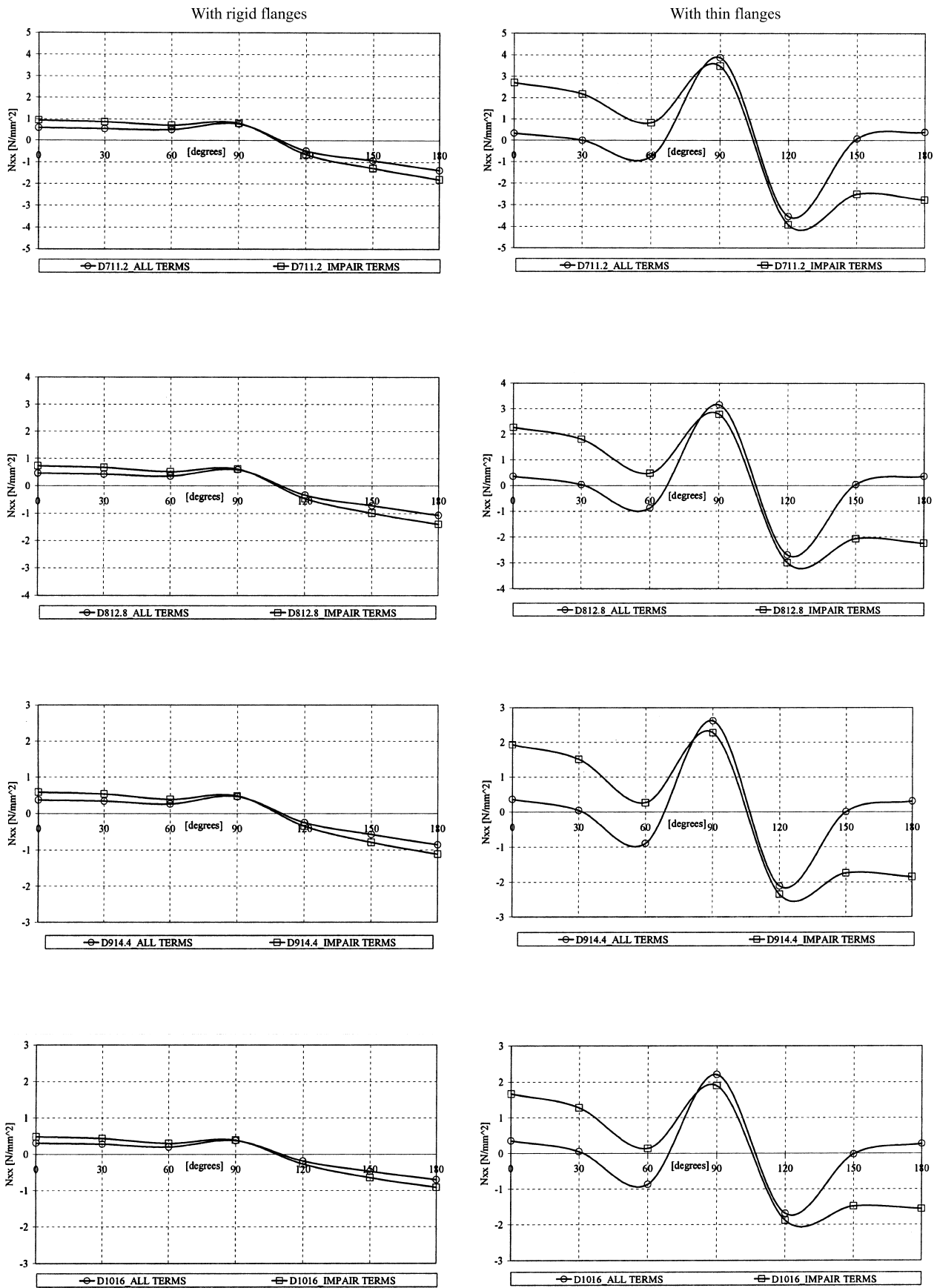

Fig. 5. (continued)

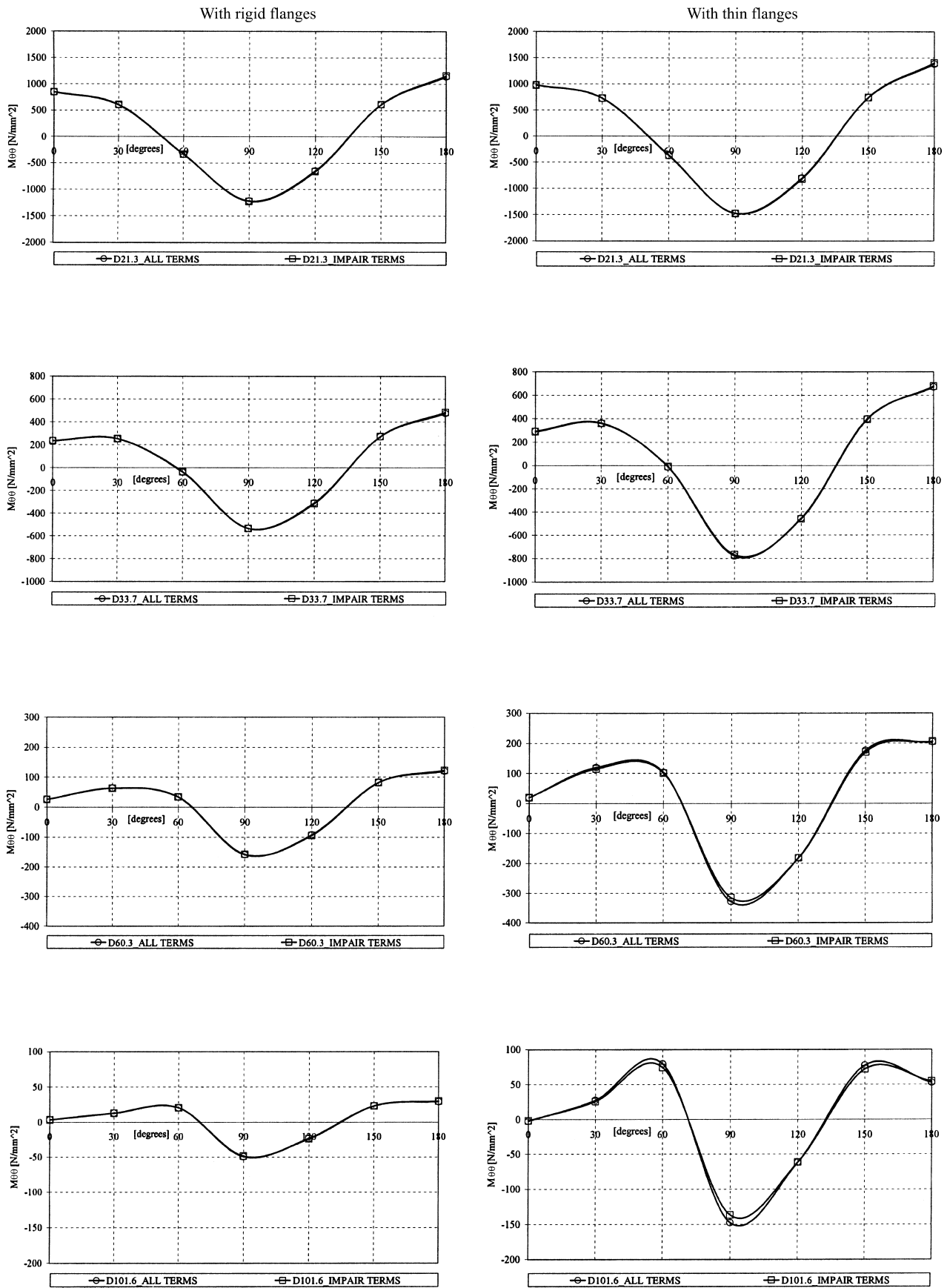

Fig. 6. Meridional bending stresses at section equidistant to edges (inside pipe surface).

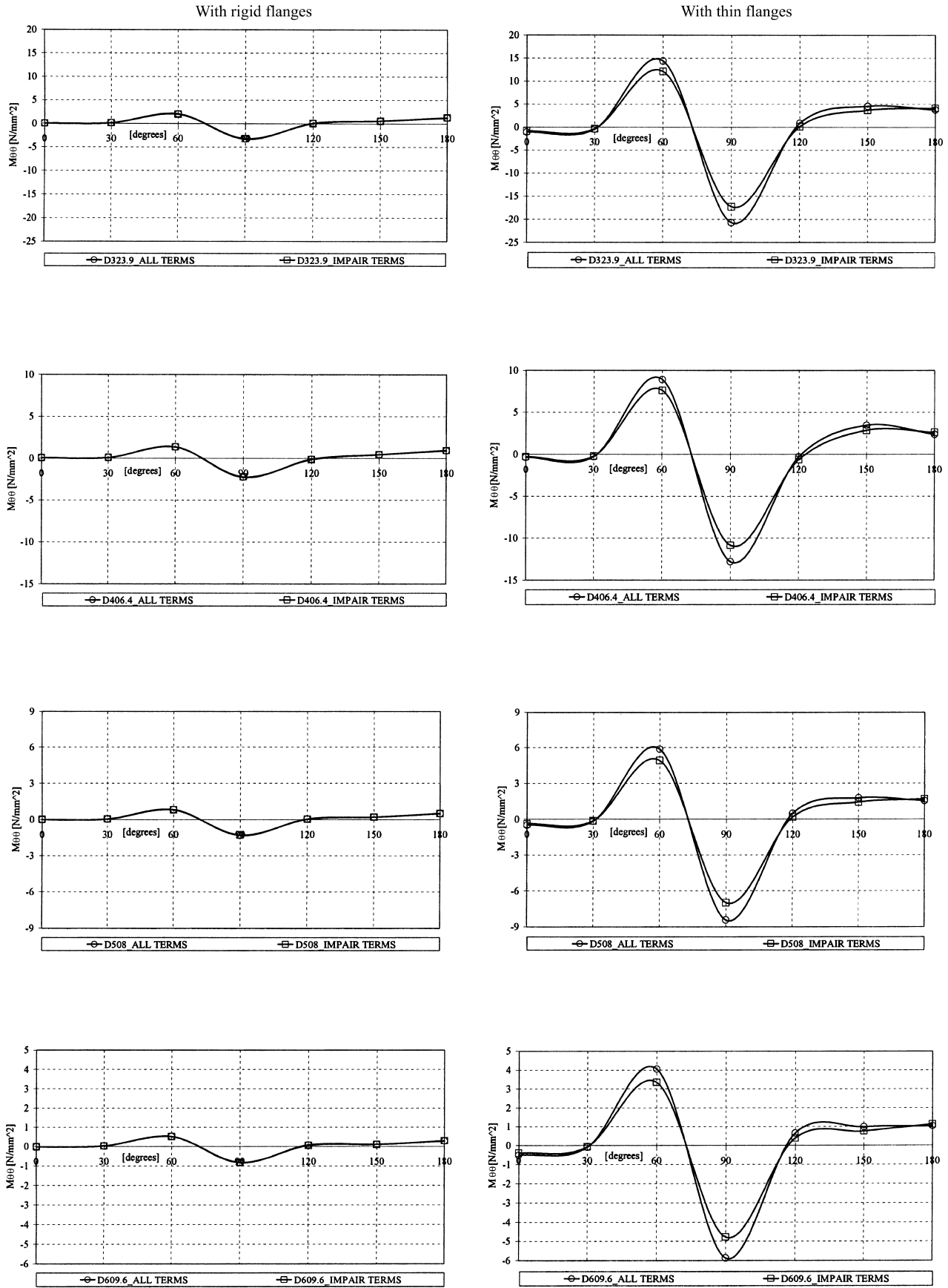

Fig. 6. (continued)

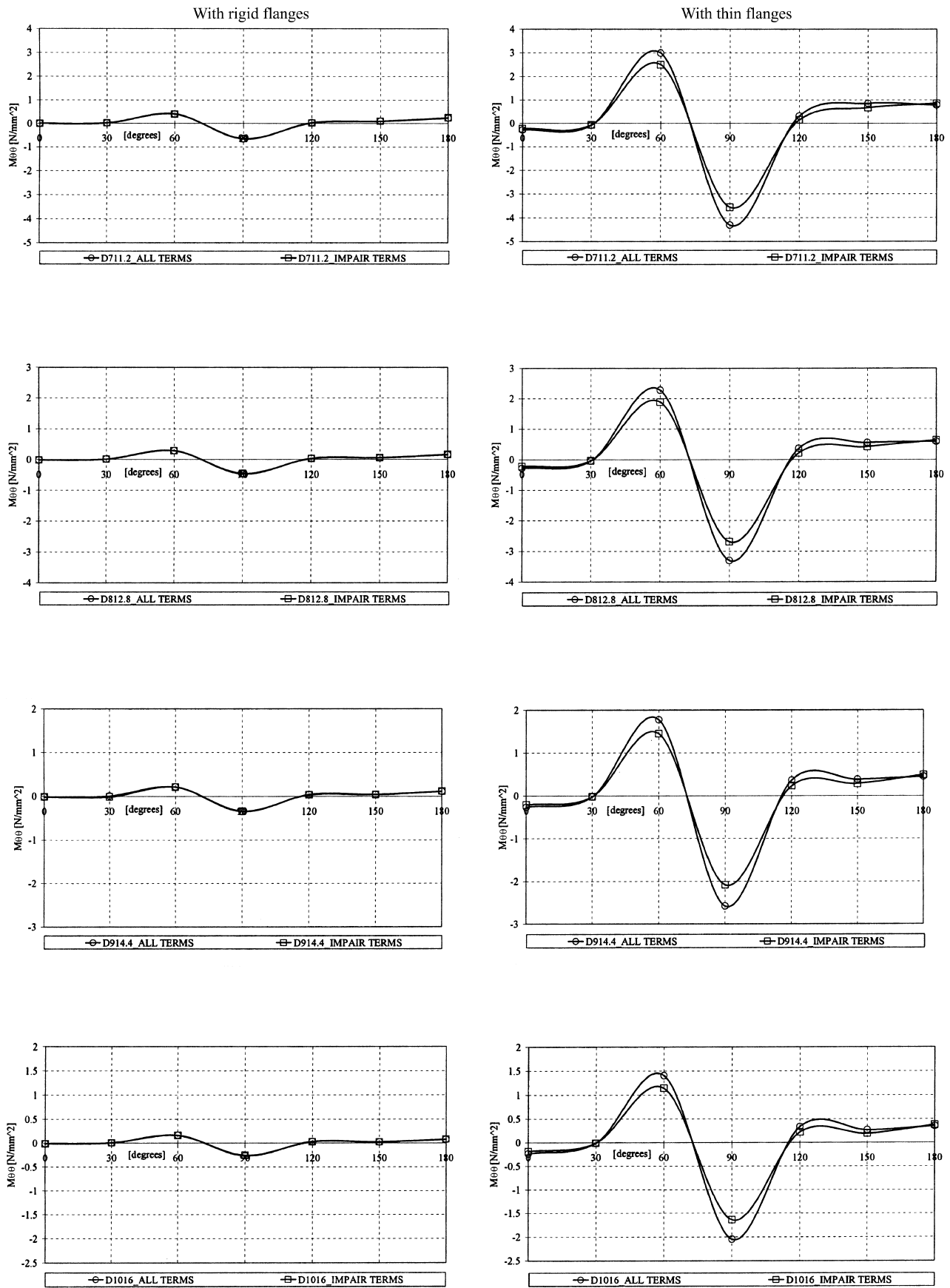

Fig. 6. (continued)

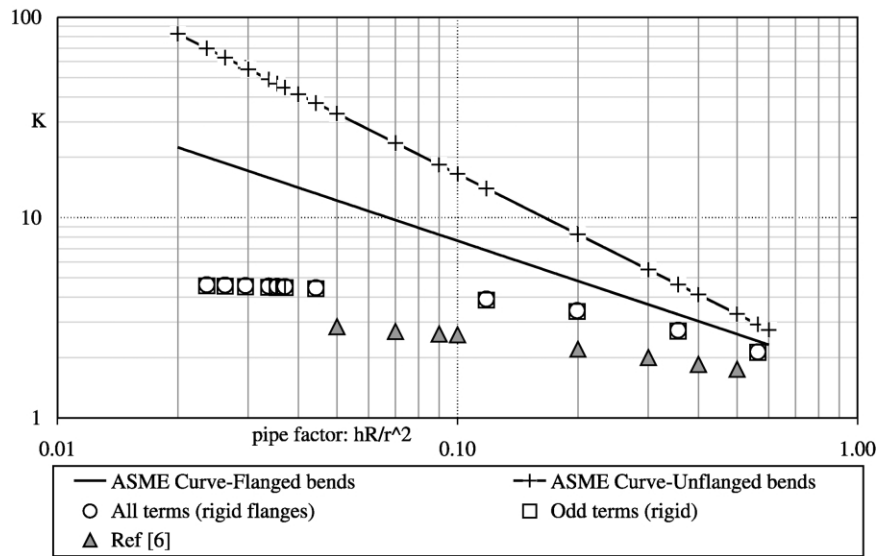

Fig. 7. Flexibility factors, curved pipes with rigid flanges.

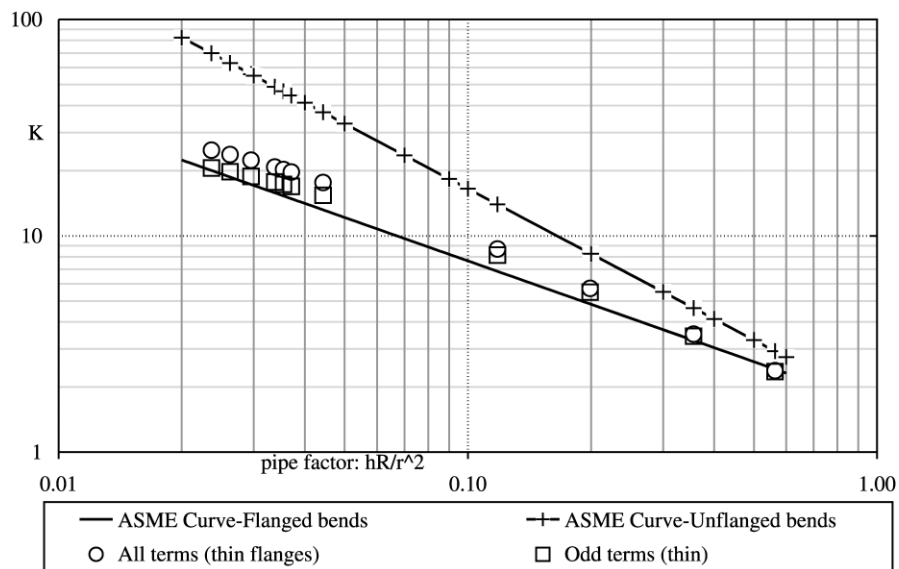

Fig. 8. Flexibility factors, curved pipes with thin flanges.

6. Calculation of the flexibility factor

According to the ASME Code, the calculation of the flexibility factor in a curved pipe under uniform bending is determined from the following equation:

$$K = \frac{1.65}{\bar{h}^{2/3}} \quad (\text{for flanged bends}) \quad (23a)$$

$$K = \frac{1.65}{\bar{h}} \quad (\text{for unflanged bends}) \quad (23b)$$

where

$$\bar{h} = \frac{hR}{r^2} \quad (24)$$

Fig. 7 shows the results obtained with the semi-analytic formulation discussed here compared with the ASME curve, considering rigid flanges for all curved pipes studied.

Fig. 8 shows the results obtained when using thin flanges. In this case the results obtained will be compared with the ASME curve for unflanged bends.

7. Conclusion

The present method is a procedure for the stress field determination or the displacement field calculations

in curved pipes, having used a semi-analytic formulation. A mathematical symbolic solver carried out the problem discussed herein, where we have formulated the displacement field using Fourier series modelling the ovalization and warping condition in curved pipes. Good agreement between our stress results and the corresponding data from other authors was observed. The calculation of the flexibility factors has shown some discrepancies related with ASME results, especially for the case of curved pipes with rigid flanges; however, better agreement was observed when such results were compared with similar data from Thomson [6]. Nevertheless, the case of thin flanges has shown better agreement with ASME results.

The present method is simple to program and easy to operate, demanding small capacity computers and avoiding a pre-processing mesh generation for the shell definition surface, an advantage for engineering designers.

References

- [1] Ohtaki S. FEM analysis of pipe bends subjected to out-of-plane bending. European Congress on Computational Methods in Applied Sciences and Engineering, ECCOMAS; 2000.
- [2] Natarajan R, Mirza S. Effect of internal pressure on flexibility factors in pipe elbows with end constraints. *J Pressure Vessel Technol* 1985;107: 60–3.
- [3] Madureira L, Melo FQ. A hybrid formulation in the stress analysis of curved pipes. *Engng Comput* 2000;17(8):970–80.
- [4] Flugge W. *Thin elastic shells*. Berlin: Springer; 1973.
- [5] Kitching R. Smooth and mitred pipe bends. In: Gill SS, editor. *The stress analysis of pressure vessels and pressure*. Oxford: Pergamon Press; 1970, chapter 7.
- [6] Thomson G. *In plane bending of smooth pipe bends*. PhD Thesis. University of Strathclyde, Scotland, UK; 1980.
- [7] Melo FJM, Castro PMST. A reduced integration Mindlin beam element for linear elastic stress analysis of curved pipes under generalized in-plane loading. *Comput Struct* 1992;43(4):787–94.
- [8] Wilczek E. *Statische Berechnung eines Rohrkrümmers mit Realen Randbedingungen*. PhD Thesis. Technischen Hochschule Aachen, Aachen; 1984.