

NEW PROPOSALS FOR THE DESIGN OF STEEL BEAM-COLUMNS UNDER FIRE CONDITIONS

Nuno LOPES, Paulo M. M. VILA REAL

University of Aveiro, Department of Civil Engineering, 3810-193 Aveiro, Portugal, & IDMEC Polo FeuP

pvreal@civil.ua.pt, nuno_lopes@civil.ua.pt

Luis SIMÕES DA SILVA

University of Coimbra, Department of Civil Engineering, Polo II, Pinhal de Marrocos, 3030-290 Coimbra, Portugal

luiss@dec.uc.pt

Paulo PILOTO

Polytechnic of Bragança, Department of Mechanical Engineering, Bragança, Portugal

ppiloto@ipb.pt

Jean-Marc FRANSSSEN

University of Liege, 1, Chemin des Chevreuils, 4000, Liège 1, Belgium

jm.franssen@ulg.ac.be

ABSTRACT

The possibility of having, in parts 1-1 and 1-2 of Eurocode 3, the same approach for the design of beam-columns and for lateral-torsional buckling, was investigated by the authors in previous papers using a numerical approach, where it was concluded that those assumptions could be made.

In the present paper, a new approach for lateral-torsional buckling has been used with the formulae for the design of beam-columns at elevated temperature based on prEN 1993-1-1 combined with the formulae from prEN 1993-1-2. In both cases the results obtained are much

better than the current design expressions, when compared with those obtained in the numerical calculations.

KEYWORDS: *steel, beam-column, lateral-torsional-buckling, fire, Eurocode 3, numerical modelling*

INTRODUCTION

The final draft of part 1-1 of Eurocode 3, prEN 1993-1-1 (2003) [1], introduced several changes in the design formulae for beam-columns and unrestrained beams with lateral-torsional buckling (LTB) at room temperature. These modifications took place during the conversion of Eurocode 3 from ENV to EN status.

Two new formulae for the design of beam-columns at room temperature have been proposed in prEN 1993-1-1 (2003) [1] as the result of extensive work made by two working groups that followed different approaches, namely, a French-Belgian team and an Austrian-German one.

Under fire conditions, in prEN 1993-1-2 (2003) [2], the proposed formulae for the design of beam-columns in case of fire have not changed and are still based on ENV 1993-1-1 (1992) [3].

In order to study the possibility of having, in parts 1-1 and 1-2 of the upcoming Eurocode 3, the same approach for beam-columns, a numerical investigation was carried out, with the conclusion that it is possible to use the formulae from the part 1-1 provided that some factors are modified to consider high temperatures [4].

Significant changes, proposed in prEN 1993-1-1 (2003) [1], have been introduced in the evaluation of the lateral-torsional buckling resistance of unrestrained beams at room temperature leading to results that are still on the safe side but less conservative than those obtained using the approach prescribed in the former ENV 1993-1-1 (1992) [3] in case of non-uniform bending.

Numerical modelling of the lateral-torsional buckling of steel beams at elevated temperature has shown that the beam design curve from prEN 1993-1-2 (2003) [2] is over-conservative for bending moment diagrams other than uniform bending moment [5].

In accordance with the safety format of the lateral-torsional buckling code provisions for room temperature design, an alternative proposal for rolled sections or equivalent welded sections subjected to fire was presented by Vila Real et al [5], that addressed the issue of the influence of the loading type on the resistance of the beam, leading to better agreement with the numerical behaviour while maintaining safety.

The objective of the present paper is to evaluate the proposals made by Vila Real et al [4] in terms of a consistent safety check for the stability of beam-columns subjected to lateral-torsional buckling under fire loading, but using the new proposal for lateral-torsional buckling of unrestrained beams in case of fire [5]. This new proposal will be also used with the design formulae for beam-columns from the prEN 1993-1-2 (2003).

More specifically, using the specialised finite element code SAFIR [6], results of second-order analysis, including imperfections, for a range of lengths, levels of axial force and loading cases, are compared with the codified interaction formulae from Part 1-2 of Eurocode 3 [2] (here

denoted “prEN 1993-1-2” when the new proposal for lateral-torsional buckling [5] is not considered and “prEN 1993-1-2 / f” when this new proposal is included) and with the proposed adaptation [4] to fire loading of method 1 and method 2 in prEN 1993-1-1 (2003), henceforth denoted “EC3 Method 1, f_i / f ” and “EC3 Method 2, f_i / f ” or “EC3 Method 1, f_i ” and “EC3 Method 2, f_i ”, again if the new proposal for LTB [5] is considered or not. Finally, the safety of these proposals is discussed and established.

CASE STUDY

A simply supported beam-column with fork supports has been chosen to explore the validity of the beam safety conditions, as shown in figure 1a). With respect to the bending moment variation along the member length, two values, (-1 and 0), of the ψ ratio (see fig. 1) have been investigated.

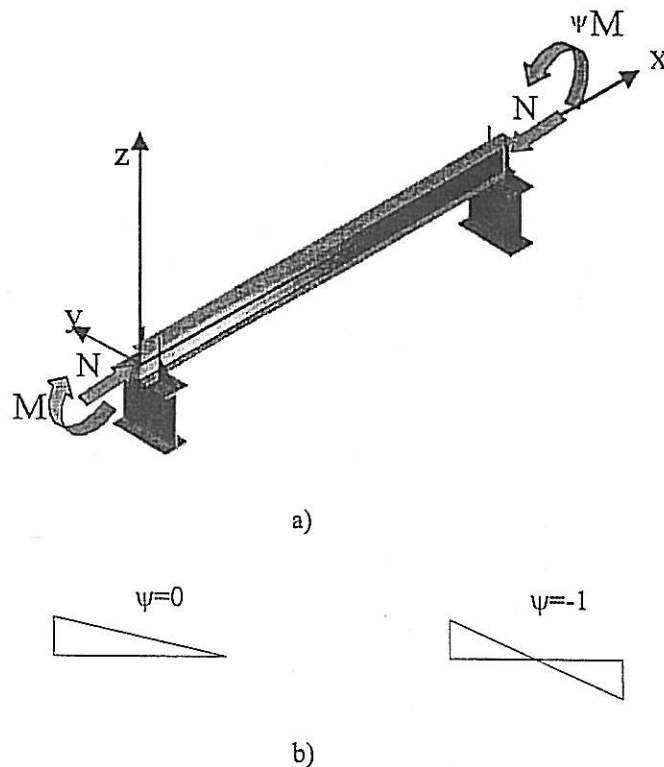

FIGURE 1 : a) Simply supported beam-column with non-uniform bending; b) Studied bending diagrams.

The case $\psi = 1$ was not studied here because this case is not affected by the new procedure for lateral-torsional buckling [5], that is, when the ψ ratio equals 1, the proposed formulae for the evaluation of the lateral-torsional buckling resistance of steel beams remains the same as those

proposed in the prEN 1993-1-2. The parametric study of beam-columns for $\psi = 1$ has already been made by Vila Real et al [4].

An IPE 220 steel section of grade S 235 has been used. Uniform temperature in the cross-section has been also used so that comparison between the numerical results and the Eurocode could be made. In this paper the temperature used was 600 °C, deemed to adequately represent the majority of practical situations.

A lateral geometric imperfection given by the following expression was considered:

$$y(x) = \frac{l}{1000} \sin\left(\frac{\pi x}{l}\right) \quad (1)$$

where l is the beam length. An initial rotation around the longitudinal axis with a maximum value of $l/1000$ rad at mid span was also introduced.

The residual stresses adopted are constant across the thickness of the web and flanges. A triangular distribution as shown in figure 2, with a maximum value of 0.3×235 MPa has been used [7].

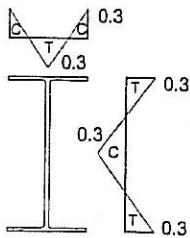

FIGURE 2 : Residual stresses: C – compression; T – tension

The lengths of the studied members were chosen so that the adimensional slenderness were smaller than 2.

IMPROVEMENT OF THE prEN 1993-1-2 PROPOSAL FOR LATERAL-TORSIONAL BUCKLING

According to the proposal of prEN 1993-1-2 [2], the lateral-torsional buckling resistance of a laterally unrestrained beam with class 1 or 2 cross-section, is obtained as follows:

$$M_{b,f,t,Rd} = \chi_{LT,f} W_{pl,y} k_{y,\theta,com} f_y \frac{1}{\gamma_{M,f}} \quad (2)$$

where $\chi_{LT,\beta}$ is given by

$$\chi_{LT,\beta} = \frac{1}{\phi_{LT,\theta,com} + \sqrt{[\phi_{LT,\theta,com}]^2 - [\bar{\lambda}_{LT,\theta,com}]^2}} \quad (3)$$

with

$$\phi_{LT,\theta,com} = \frac{1}{2} \left[1 + \alpha \bar{\lambda}_{LT,\theta,com} + (\bar{\lambda}_{LT,\theta,com})^2 \right] \quad (4)$$

The non-dimensional slenderness $\bar{\lambda}_{LT,\theta,com}$ (or $\bar{\lambda}_{LT,\beta}$, if the temperature field in the cross section is uniform) is given by

$$\bar{\lambda}_{LT,\theta,com} = \bar{\lambda}_{LT,\beta} = \bar{\lambda}_{LT} \sqrt{\frac{k_{y,\theta,com}}{k_{E,\theta,com}}} \quad (5)$$

In this proposal, the imperfection factor α is a function of the steel grade and is given by:

$$\alpha = 0.65 \sqrt{235 / f_y} \quad (6)$$

As these formulae (from prEN 1993-1-2) lead to over conservative results when compared to numerical results for the case of non-uniform bending, Vila Real et al [5] have made a new proposal that adopts a modified reduction factor for lateral-torsional buckling, $\chi_{LT,\beta,mod}$, given by

$$\chi_{LT,\beta,mod} = \frac{\chi_{LT,\beta}}{f} \quad \text{but} \quad \chi_{LT,\beta,mod} \leq 1 \quad (7),$$

where f depends on the loading type and is given by the following equation

$$f = 1 - 0.5(1 - k_c) \quad (8)$$

where k_c is a correction factor according to table 1.

Moment distribution	Class 1, 2, 3 sections
	k_c
 <p style="text-align: center;">$-1 \leq \psi \leq 1$</p>	$0.6 + 0.3\psi + 0.15\psi^2$ but $k_c \leq 1$

Table 1 : Correction factors k_c for the new proposal

INTERACTION FORMULAE FOR BEAM-COLUMNS AT HIGH TEMPERATURES

Interaction formulae proposed by prEN 1993-1-2

For fire loading, according to the new version of part 1-2 of Eurocode 3 [2], the interaction equations for beam-columns are:

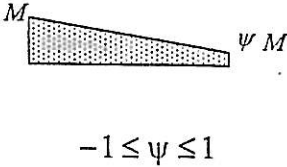
$$\frac{N_{f,Ed}}{\chi_{z,f} A k_{y,\theta} \frac{f_y}{\gamma_{M,f}}} + \frac{K_{LT} M_{y,f,Ed}}{\chi_{LT,f} W_{pl,y} k_{y,\theta} \frac{f_y}{\gamma_{M,f}}} \leq 1 \quad (9)$$

where

$$K_{LT} = 1 - \frac{\mu_{LT} N_{f,Ed}}{\chi_{z,f} A k_{y,\theta} \frac{f_y}{\gamma_{M,f}}} \quad \text{but } K_{LT} \leq 1.0 \quad (10)$$

and

$$\mu_{LT} = 0.15 \bar{\lambda}_{z,\theta} \beta_{M,LT} - 0.15 \quad \text{but } \mu \leq 0.9 \quad (11)$$

Here $\chi_{z,f}$ is the reduction factor for flexural buckling around the zz axis, and $\chi_{LT,f}$ is the reduction factor for lateral-torsional buckling, given by (4). These formulae for the design of beam-columns are based on the ENV 1993-1-1 (1992) [3].

To study the described methods, for each selected beam-column length and bending moment ratio ψ (0 and -1), illustrated in figures 3 and 4, the interaction equation (9) was plotted for increasing ratios of $N/N_{fi,Rd}$, together with the results of the numerical simulations for a uniform temperature of 600°C. In these figures, the results from equation (9) are denoted by “prEN 1993-1-2” whenever the new proposal for LTB is not considered and “prEN 1993-1-2 / f” otherwise.

From figures 3 and 4 it is concluded that the new proposal for LTB introduces a significant improvement in the interaction diagrams, for beam-columns with lateral-torsional buckling.

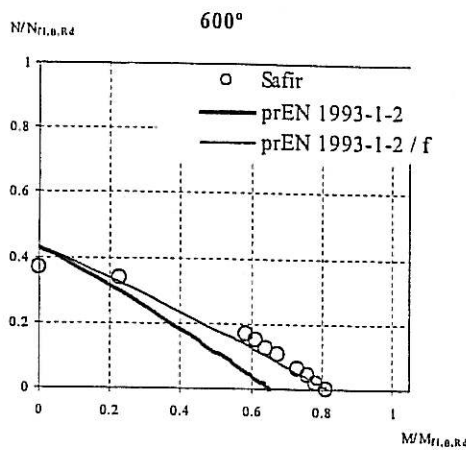

a) $L=2000mm$; $\bar{\lambda}_{LT,fi}=0.62$; $\bar{\lambda}_{y,fi}=0.29$;

$$\bar{\lambda}_{z,fi}=1.06$$

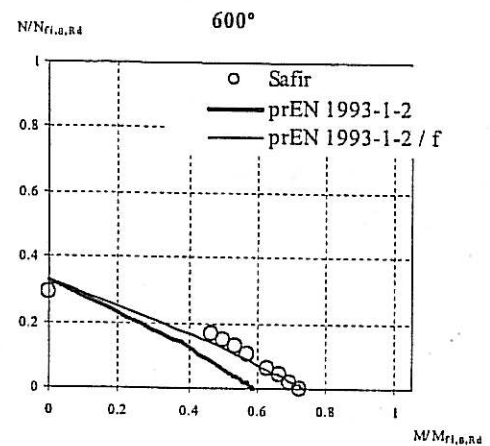

b) $L=2500mm$; $\bar{\lambda}_{LT,fi}=0.73$; $\bar{\lambda}_{y,fi}=0.36$;

$$\bar{\lambda}_{z,fi}=1.32$$

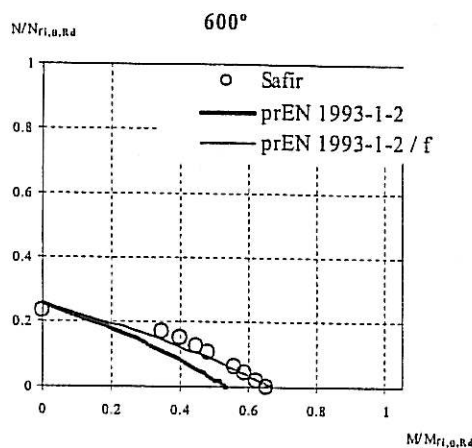

c) $L=3000mm$; $\bar{\lambda}_{LT,fi}=0.84$; $\bar{\lambda}_{y,fi}=0.43$;

$$\bar{\lambda}_{z,fi}=1.59$$

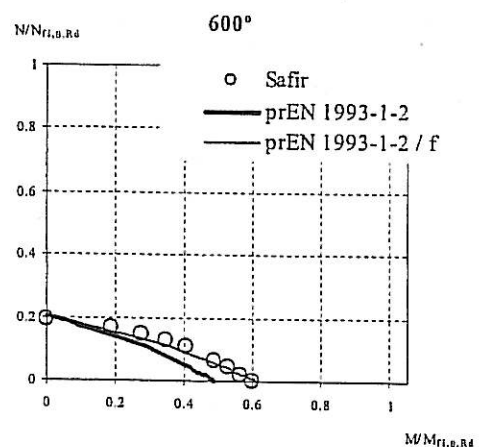

d) $L=3500mm$; $\bar{\lambda}_{LT,fi}=0.93$; $\bar{\lambda}_{y,fi}=0.50$;

$$\bar{\lambda}_{z,fi}=1.85$$

FIGURE 3 : Interaction diagrams of prEN 1993-1-2, for $\psi = 0$

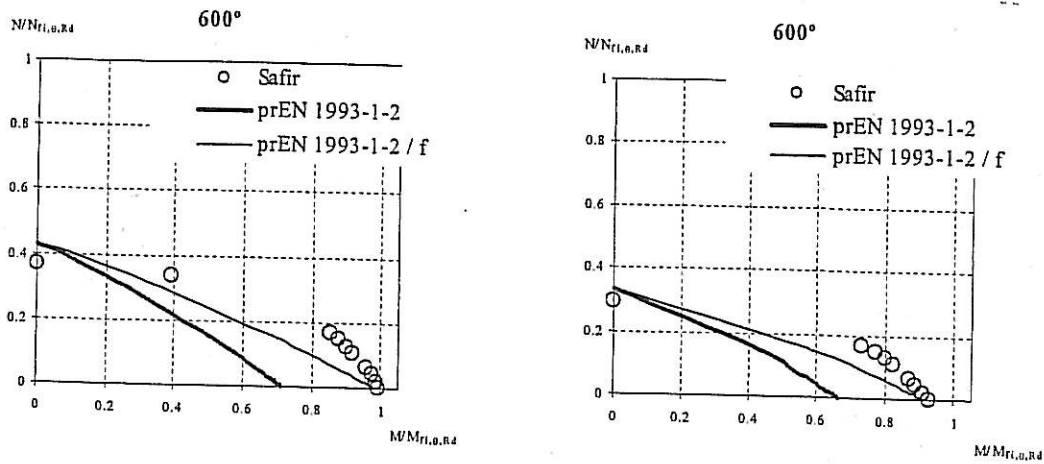

a) $L=2000mm$; $\bar{\lambda}_{LT,fi} = 0.51$; $\bar{\lambda}_{y,fi} = 0.29$;

b) $L=2500mm$; $\bar{\lambda}_{LT,fi} = 0.61$; $\bar{\lambda}_{y,fi} = 0.36$;

$$\bar{\lambda}_{z,fi} = 1.06$$

$$\bar{\lambda}_{z,fi} = 1.32$$

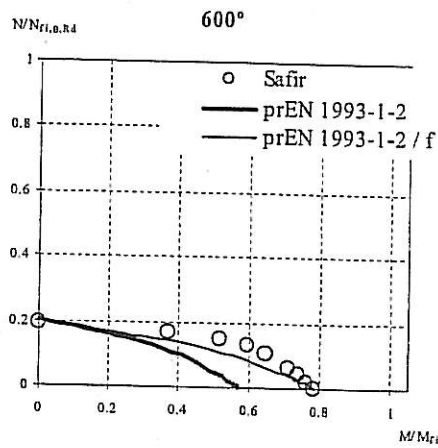
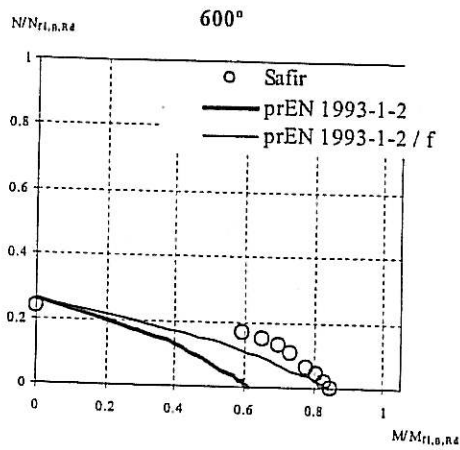

c) $L=3000mm$; $\bar{\lambda}_{LT,fi} = 0.69$; $\bar{\lambda}_{y,fi} = 0.43$;

d) $L=3500mm$; $\bar{\lambda}_{LT,fi} = 0.77$; $\bar{\lambda}_{y,fi} = 0.50$;

$$\bar{\lambda}_{z,fi} = 1.59$$

$$\bar{\lambda}_{z,fi} = 1.85$$

FIGURE 4 : Interaction diagrams of prEN 1993-1-2, for $\psi = -1$

Proposed Interaction Formulae based on prEN 1993-1-1 proposal

Vila Real et al [4] have proposed the following interaction formulae for beam-columns in case of fire:

$$\frac{N_{fi,Ed}}{\chi_{y,fi} \frac{N_{fi,Rk}}{\gamma_{M,fi}}} + k_{yy,fi} \frac{M_{y,fi,Ed} + \Delta M_{y,fi,Ed}}{\chi_{LT,fi} \frac{M_{y,fi,Rk}}{\gamma_{M,fi}}} \leq 1 \quad (12a)$$

$$\frac{N_{fi,Ed}}{\chi_{z,fi} \frac{N_{fi,Rk}}{\gamma_{M,fi}}} + k_{zy,fi} \frac{M_{y,fi,Ed} + \Delta M_{y,fi,Ed}}{\chi_{LT,fi} \frac{M_{y,fi,Rk}}{\gamma_{M,fi}}} \leq 1 \quad (12b),$$

These interaction formulae are based on the prEN 1993-1-1 provided that some factors are changed to take into consideration high temperatures. The changed factors are the yield stress, the Young modulus, and the reduction factors χ_{fi} for flexural buckling around the yy and zz axes, and $\chi_{LT,fi}$ for lateral-torsional buckling according to the proposals of prEN 1993-1-2.

The factors $k_{yy,fi}$ and $k_{zy,fi}$ are the interaction factors in case of fire that can be determined by two alternative methods (“EC3 Method 1, fi” and “EC3 Method 2, fi”) described in Vila Real et al [4]. If the new proposal of Vila Real et al [5] for lateral-torsional buckling is used, two additional methods are obtained (“EC3 Method 1, fi / f” and “EC3 Method 2, fi / f”) all illustrated in figures 6 to 9.

The procedure for the evaluation of the interaction factors for “EC3 Method 1, fi” is based on method 1 at room temperature, that is reported in Annex A of part 1-1 of EC3 [1] and was developed by a French-Belgian team [8] combining theoretical rules and numerical calibration to account for all the differences between the real model and the theoretical one. The specific formulae for the calculation of the interaction factors according to method 1 in case of fire are:

$$k_{yy,fi} = c_{my,fi} c_{mLT,fi} \frac{\mu_{y,\theta}}{1 - \frac{N_{fi,Ed}}{N_{cr,y,fi}}} \cdot \frac{1}{c_{yy,fi}} \quad (13)$$

$$k_{zy,fi} = c_{my,fi} c_{mLT,fi} \frac{\mu_{z,\theta}}{1 - \frac{N_{fi,Ed}}{N_{cr,y,fi}}} \cdot \frac{1}{c_{zy,fi}} 0.6 \sqrt{\frac{w_y}{w_z}} \quad (14),$$

where

$$c_{my,fi} = c_{my,fi,0} + (1 - c_{my,fi,0}) \frac{\sqrt{\varepsilon_{y,fi} a_{LT}}}{1 + \sqrt{\varepsilon_{y,fi} a_{LT}}} \quad (15)$$

$$c_{mLT,fi} = c_{my,fi}^2 \frac{a_{LT}}{\sqrt{\left(1 - \frac{N_{fi,Ed}}{N_{cr,z,fi}}\right) \left(1 - \frac{N_{fi,Ed}}{N_{cr,T,fi}}\right)}} \quad (16)$$

$$\varepsilon_{y,fi} = \frac{M_{y,fi,Ed}}{N_{fi,Ed}} \cdot \frac{A}{W_{el,y}} \quad (17)$$

Due to the non-linearity introduced by the factor ε_y the interaction curves were obtained using an iterative procedure. It was assumed that the moment of each studied beam-column could not exceed its design buckling resistance moment, $M_{b,Rd,fi}$. This justifies the vertical branch of some interaction curves of method 1.

“EC3 Method 2, fi” is related to method 2 at room temperature, which is described in Annex B of part 1-1 of EC3 [1] and results from an Austrian-German proposal [9] that attempted to simplify the verification of the stability of beam-columns, all interaction factors being obtained by means of numerical calibration. These factors are not clearly understandable from a physical point of view, but this simple formulation simplifies the verification procedure and reduces the possibility of mistakes.

The interaction factors according to method 2 in case of fire must be calculated from:

$$k_{yy,fi} = c_{my,fi} \left(1 + (\bar{\lambda}_{y,\theta} - 0.2) \frac{N_{fi,Ed}}{\chi_{y,fi} \frac{N_{fi,Rk}}{\gamma_{M,fi}}} \right) \leq c_{my,fi} \left(1 + 0.8 \frac{N_{fi,Ed}}{\chi_{y,fi} \frac{N_{fi,Rk}}{\gamma_{M,fi}}} \right) \quad (18)$$

$$k_{zy} = 1 - \frac{0.1 \bar{\lambda}_{z,\theta}}{c_{mLT} - 0.25} \cdot \frac{N_{fi,Ed}}{\chi_{z,fi} \frac{N_{fi,Rk}}{\gamma_{M,fi}}} \geq 1 - \frac{0.1}{c_{mLT} - 0.25} \cdot \frac{N_{fi,Ed}}{\chi_{z,fi} \frac{N_{fi,Rk}}{\gamma_{M,fi}}} \quad (19)$$

for $\bar{\lambda}_{z,\theta} < 0.4$:

$$k_{zy} = 0.6 + \bar{\lambda}_{z,\theta} \leq 1 - \frac{0.1 \bar{\lambda}_{z,\theta}}{c_{mLT} - 0.25} \cdot \frac{N_{fi,Ed}}{\chi_{z,fi} \frac{N_{fi,Rk}}{\gamma_{M,fi}}}$$

where

$$c_{m,fi} = 0.6 + 0.4\psi_1 \geq 0.4 \quad (20)$$

Figures 5 and 6 show the influence of considering or not the new proposal for LTB [5] with method 1 and method 2 adapted to elevated temperatures, for $\psi = 0$ and $\psi = -1$ respectively. It can be observed in those figures that the new proposal for LTB introduces a great improvement in the interaction diagrams for both methods.

Finally in figures 7 and 8, all the three methods studied here, considering the new proposal for the lateral-torsional buckling of beams [5] are plotted together, showing a very good agreement with the numerical results.

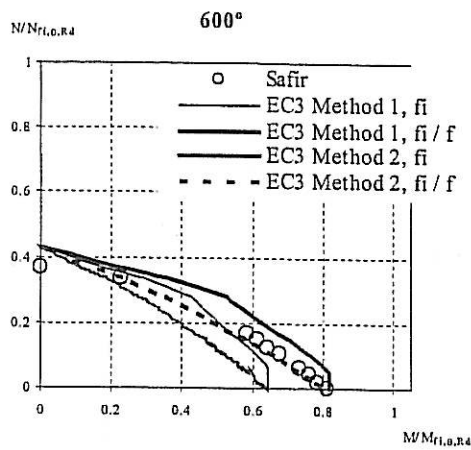

a) $L=2000mm$; $\bar{\lambda}_{LT,fi} = 0.62$; $\bar{\lambda}_{y,fi} = 0.29$;
 $\bar{\lambda}_{z,fi} = 1.06$

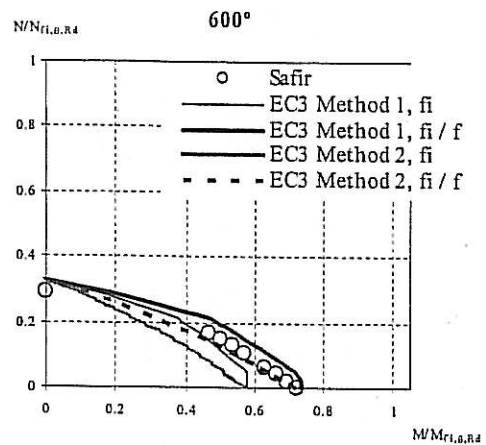

b) $L=2500mm$; $\bar{\lambda}_{LT,fi} = 0.73$; $\bar{\lambda}_{y,fi} = 0.36$;
 $\bar{\lambda}_{z,fi} = 1.32$

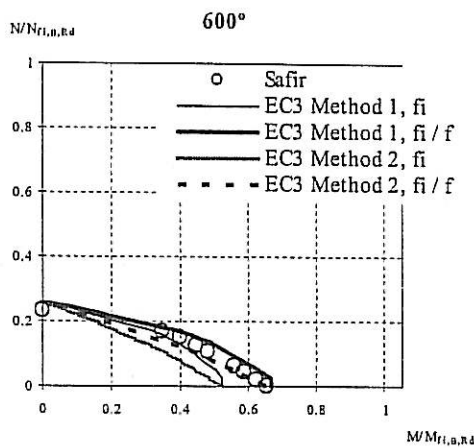

c) $L=3000mm$; $\bar{\lambda}_{LT,fi} = 0.84$; $\bar{\lambda}_{y,fi} = 0.43$;
 $\bar{\lambda}_{z,fi} = 1.59$

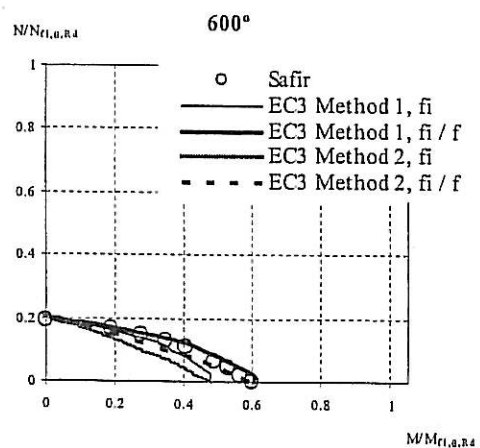

d) $L=3500mm$; $\bar{\lambda}_{LT,fi} = 0.93$; $\bar{\lambda}_{y,fi} = 0.50$;
 $\bar{\lambda}_{z,fi} = 1.85$

FIGURE 5 : Interaction diagrams of adapted prEN 1993-1-1 at 600 °C for $\psi = 0$

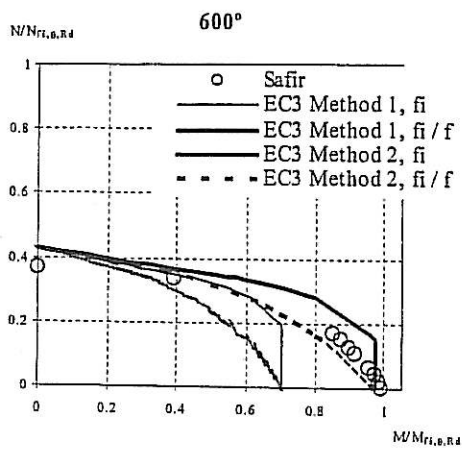

a) $L=2000mm$; $\bar{\lambda}_{LT,fi}=0.51$; $\bar{\lambda}_{y,fi}=0.29$;

$$\bar{\lambda}_{z,fi}=1.06$$

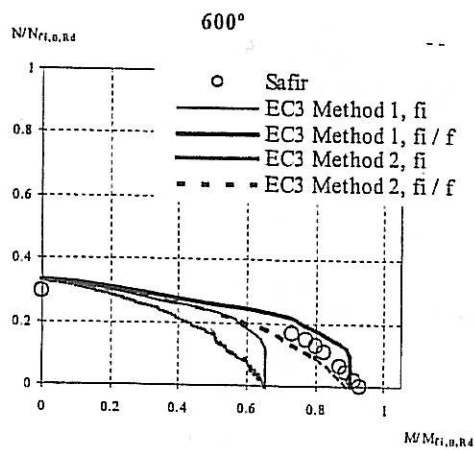

b) $L=2500mm$; $\bar{\lambda}_{LT,fi}=0.61$; $\bar{\lambda}_{y,fi}=0.36$;

$$\bar{\lambda}_{z,fi}=1.32$$

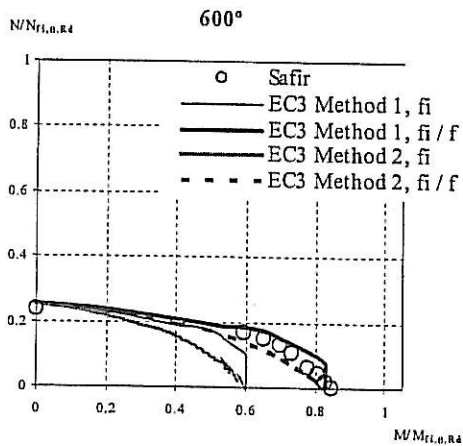

c) $L=3000mm$; $\bar{\lambda}_{LT,fi}=0.69$; $\bar{\lambda}_{y,fi}=0.43$;

$$\bar{\lambda}_{z,fi}=1.59$$

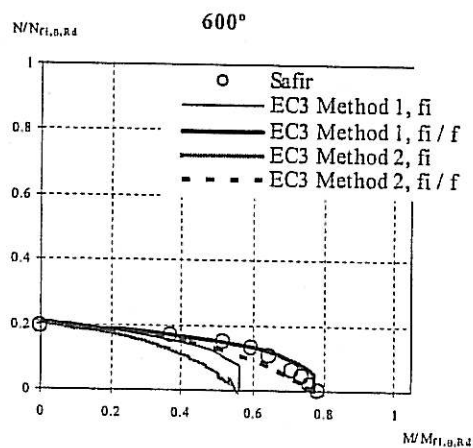

d) $L=3500mm$; $\bar{\lambda}_{LT,fi}=0.77$; $\bar{\lambda}_{y,fi}=0.50$;

$$\bar{\lambda}_{z,fi}=1.85$$

FIGURE 6 : Interaction diagrams of adapted prEN 1993-1-1 at 600 °C for $\psi = -1$

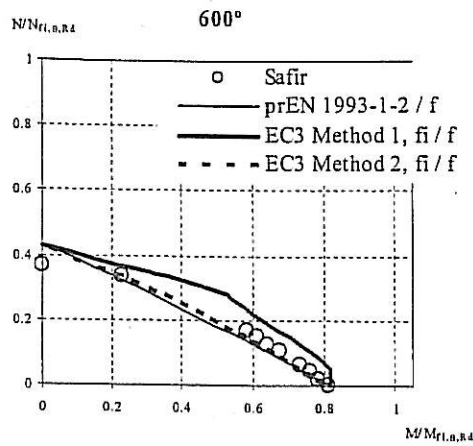

a) - $L=2000\text{mm}$; $\bar{\lambda}_{LT,fi}=0.62$; $\bar{\lambda}_{y,fi}=0.29$;

$$\bar{\lambda}_{z,fi}=1.06$$

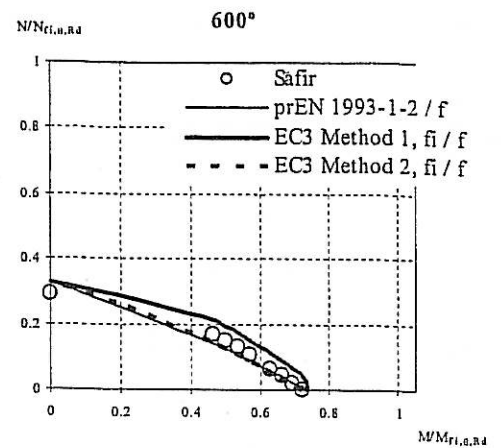

b) - $L=2500\text{mm}$; $\bar{\lambda}_{LT,fi}=0.73$; $\bar{\lambda}_{y,fi}=0.36$;

$$\bar{\lambda}_{z,fi}=1.32$$

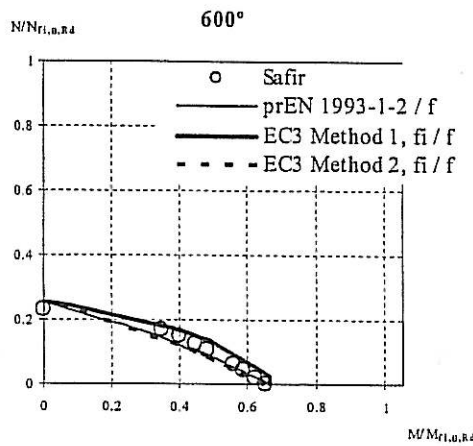

c) - $L=3000\text{mm}$; $\bar{\lambda}_{LT,fi}=0.84$; $\bar{\lambda}_{y,fi}=0.43$;

$$\bar{\lambda}_{z,fi}=1.59$$

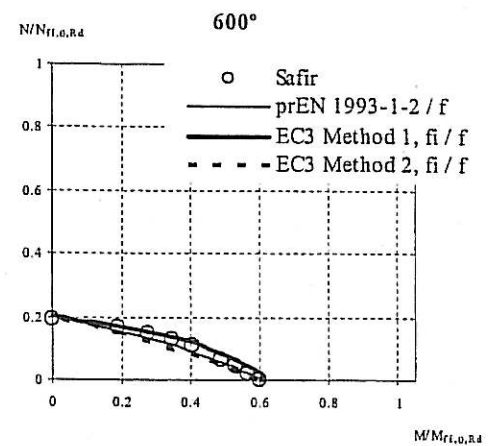

d) - $L=3500\text{mm}$; $\bar{\lambda}_{LT,fi}=0.93$; $\bar{\lambda}_{y,fi}=0.50$;

$$\bar{\lambda}_{z,fi}=1.85$$

FIGURE 7 : Interaction diagrams considering the new proposal for lateral-torsional buckling, for $\psi = 0$

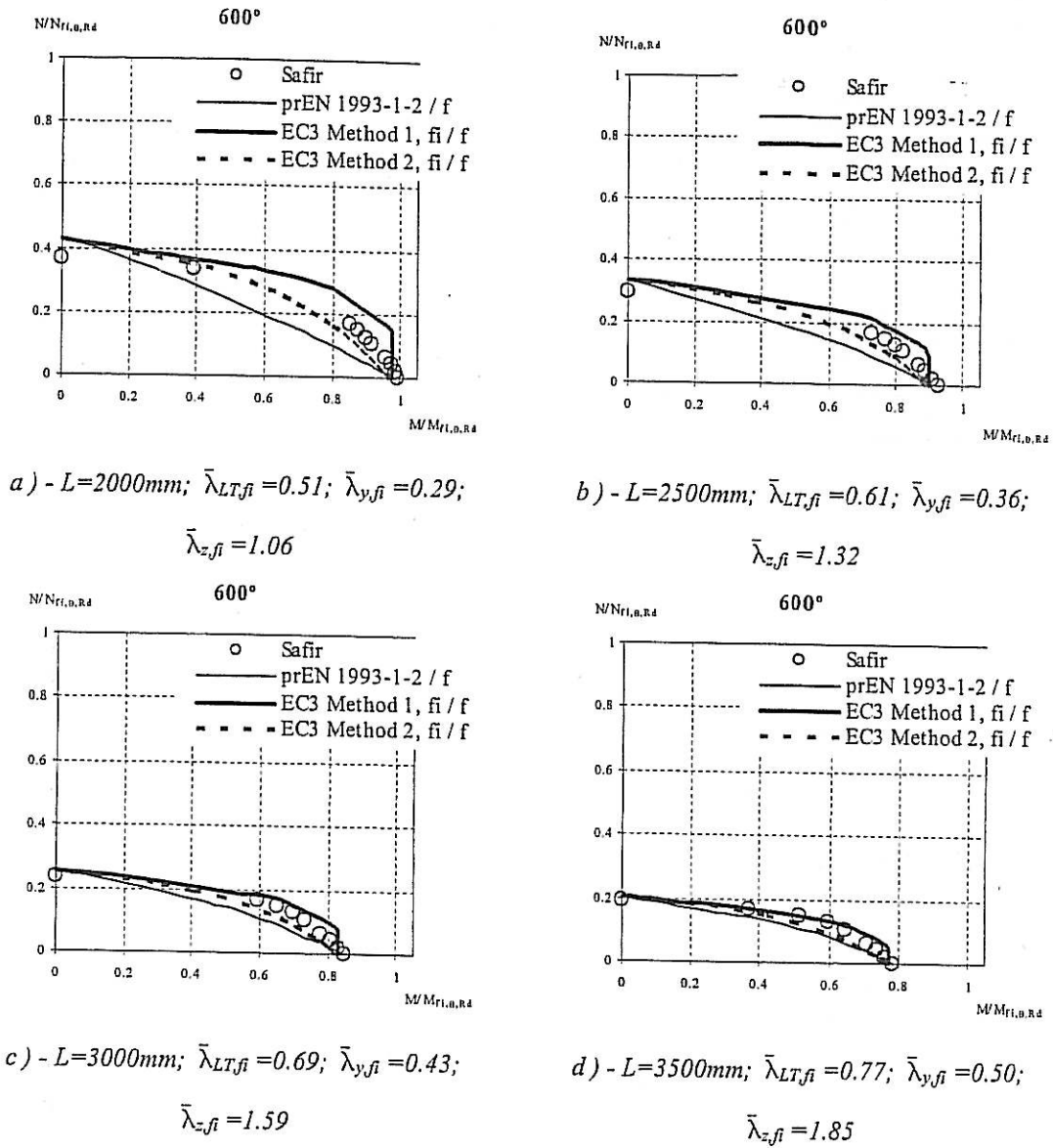

FIGURE 8 : Interaction diagrams considering the new proposal for lateral-torsional buckling, for $\psi = -1$

Critical temperature

The verification of the fire resistance of steel members can be made in the temperature domain, imposing that the temperature does not exceed the critical temperature during the relevant duration of fire exposure.

The critical temperature according to Eurocode 3 can be calculated with

$$\theta_{a,cr} = 39,19 \ln \left[\frac{1}{0,9674 \mu_0^{3,833}} - 1 \right] + 482 \quad (21)$$

where the degree of utilization μ_0 , for members subjected to combined bending and axial compression according to the prEN 1993-1-2 is given by the following expression

$$\mu_0 = \frac{N_{f,Ed}}{\chi_{z,f} A \frac{f_y}{\gamma_{M,f}}} + \frac{K_{LT} M_{y,f,Ed}}{\chi_{LT,f} W_{pl,y} \frac{f_y}{\gamma_{M,f}}} \quad (22)$$

and for the proposal presented in this paper, for method 1 and method 2 given by

$$\mu_0 = \frac{N_{f,Ed}}{\chi_{y,f} A \frac{f_y}{\gamma_{M,f}}} + k_{yy,f} \frac{M_{y,f,Ed}}{\chi_{LT,f} W_{pl,y} \frac{f_y}{\gamma_{M,f}}} \quad (23)$$

and

$$\mu_0 = \frac{N_{f,Ed}}{\chi_{z,f} A \frac{f_y}{\gamma_{M,f}}} + k_{zy,f} \frac{M_{y,f,Ed}}{\chi_{LT,f} W_{pl,y} \frac{f_y}{\gamma_{M,f}}} \quad (24)$$

As for the buckling of axial compressed members and the lateral-torsional buckling of beams, an iterative procedure is necessary.

DESIGN EXAMPLE

Considering an isostatic unrestrained beam with an IPE 220, with 2 m of length, subjected to a bending diagram resultant of moments applied at the extremities with $\psi = -1$ and to an axial compression effort. Assuming that the beam is in steel of the grade S 235, that the moment in the extremities in fire situation, around the strong axis, is $M_{y,f,d} = \pm 20 \text{ kN} \cdot \text{m}$ and that the axial compression is $N_{f,d} = 100 \text{ kN}$, calculate the critical temperature in accordance with

- The latter version of part 1-2 of Eurocode 3 (prEN 1993-1-2).
- The latter version of part 1-2 of Eurocode 3 but introducing the factor f to determine the modified reduction factor, according to equation (7).
- The adaptation of Method 1 at high temperatures with factor f to determine the modified reduction factor, according to equation (7).

d) The adaptation of Method 2 at high temperatures with factor f to determine the modified reduction factor, according to equation (7).

Resolution:

The following values will be needed for the resolution of the problem:

- Young's modulus	$E = 210\,000 \text{ N/mm}^2$
- Shear modulus	$G = E / [2(1 + \nu)] \text{ N/mm}^2$
- Poisson's ratio	$\nu = 0,3$
- Length	$L = 2000 \text{ mm}$
- Class of the cross-section	class 1
- Area of the cross-section	$A = 3337 \text{ mm}^2$
- Plastic section modulus in y axis	$W_{pl,y} = 285400 \text{ mm}^3$
- Radius of gyration around yy	$i_y = 91,1 \text{ mm}$
- Radius of gyration around zz	$i_z = 24,8 \text{ mm}$
- Second moment of area around zz	$I_z = 2049 \times 10^3 \text{ mm}^4$
- Warping constant	$I_w = 2,27 \times 10^{10} \text{ mm}^6$
- Torsion constant	$I_t = 90700 \text{ mm}^4$

a) The beam can undergo lateral-torsional buckling therefore the degree of utilization of the beam is calculated with the equation (22)

$$\mu_0 = \frac{N_{f,Ed}}{\chi_{z,f} A \frac{f_y}{\gamma_{M,f}}} + \frac{K_{LT} M_{y,f,Ed}}{\chi_{LT,f} W_{pl,y} \frac{f_y}{\gamma_{M,f}}}$$

The elastic critical moment for lateral-torsional buckling is

$$M_{cr} = C_1 \frac{\pi^2 EI_z}{L^2} \sqrt{\frac{I_w}{I_z} + \frac{L^2 GI_t}{\pi^2 EI_z}} \times 10^{-6} = 370 \text{ kN} \cdot \text{m}$$

The non-dimensional slenderness takes the value

$$\bar{\lambda}_{LT} = \sqrt{W_{pl,y} f_y / M_{cr}} = 0,426$$

and at 20 °C

$$\bar{\lambda}_{LT,20^\circ} = \bar{\lambda}_{LT} \sqrt{k_{y,20^\circ} / k_{E,20^\circ}} = 0,426 \sqrt{1,0 / 1,0} = 0,426$$

giving

$$\phi_{LT,20^\circ} = \frac{1}{2} (1 + 0,65 \cdot 0,426 + 0,426^2) = 0,729$$

and

$$\chi_{LT,\beta} = \frac{1}{0,729 + \sqrt{0,729^2 - 0,426^2}} = 0,757$$

The slenderness at room temperature is

$$\lambda_z = \frac{l_{\beta}}{i_z} = \frac{2000}{24,8} = 80,6$$

which gives

$$\bar{\lambda}_z = \frac{\lambda_z}{\lambda_1} = \frac{80,6}{93,9} = 0,859$$

at 20 °C

$$\bar{\lambda}_{z,20^\circ} = \bar{\lambda}_z \sqrt{k_{y,20^\circ} / k_{E,20^\circ}} = \bar{\lambda}_z = 0,859$$

and

$$\phi_{z,20^\circ} = \frac{1}{2} (1 + 0,65 \cdot 0,859 + 0,859^2) = 1,149$$

from the other hand

$$\mu_{LT} = 0,15 \bar{\lambda}_{z,20^\circ} \beta_{M,LT} - 0,15 \leq 0,9$$

where

$$\beta_{M,LT} = 2,5$$

giving

$$\mu_{LT} = 0,15 \cdot 0,859 \cdot 2,5 - 0,15 = 0,172$$

and

$$k_{LT} = 1 - \frac{\mu_{LT} N_{\beta,Ed}}{\chi_{z,\beta} A k_{y,0} \frac{f_y}{\gamma_{M,\beta}}} \leq 1$$

At 20 °C the reduction factor for the buckling $\chi_{z,\beta}$ is

$$\chi_{z,\beta} = \frac{1}{1,149 + \sqrt{1,149^2 - 0,859^2}} = 0,523$$

giving

$$k_{LT} = 1 - \frac{0,172 \cdot 100 \times 10^3}{0,523 \cdot 3337 \cdot 1,0 \cdot \frac{235}{1,0}} = 0,958$$

and the degree of utilization

$$\mu_0 = \frac{100 \times 10^3}{0,523 \cdot 3337 \cdot 235} + \frac{0,958 \cdot 20 \times 10^6}{0,757 \cdot 285,4 \times 10^3 \cdot 235} = 0,621$$

resulting in the following critical temperature

$$\theta_{a,cr} = 39,19 \ln \left(\frac{1}{0,9674 \cdot 0,621^{3,833}} - 1 \right) + 482 = 548 \text{ °C}$$

With this critical temperature the calculation can all be repeated to obtain a new critical temperature. The iterative process must be repeated until convergence is reached, as shown in the following table:

θ [°C]	$\bar{\lambda}_{z,\theta} = \bar{\lambda}_z \cdot \sqrt{\frac{k_{y,\theta}}{k_{E,\theta}}}$	$\bar{\lambda}_{LT,\theta} = \bar{\lambda}_{LT} \cdot \sqrt{\frac{k_{y,\theta}}{k_{E,\theta}}}$	$\chi_{z,\beta}$	$\chi_{LT,\beta}$	k_{LT}	$\mu_0 = \frac{N_{\beta,Ed}}{\chi_{z,\beta} A f_y / \gamma_{M,\beta}} + \frac{k_{LT} M_{y,\beta,Ed}}{\chi_{LT,\beta} W_{pl,y} f_y / \gamma_{M,\beta}}$	$\theta_{a,cr}$ [°C]
20	0.859	0.426	0.523	0.757	0.958	0.621	548
548	1.006	0.498	0.453	0.717	0.898	0.655	539
539	1.000	0.495	0.456	0.719	0.905	0.655	539

After convergence the critical temperature is

$$\theta_{a,cr} = 539 \text{ °C}$$

b) Now the last version of part 1-2 of Eurocode 3 used in the previous question but with factor f considered in this paper in the equation (8) (prEN 1993-1-2 / f) will be used. The iterative process is summarized in the following table

θ [°C]	$\bar{\lambda}_{z,\theta} = \bar{\lambda}_z \cdot \sqrt{\frac{k_{y,\theta}}{k_{E,\theta}}}$	$\bar{\lambda}_{LT,\theta} = \bar{\lambda}_{LT} \cdot \sqrt{\frac{k_{y,\theta}}{k_{E,\theta}}}$	$\chi_{z,\beta}$	$\chi_{LT,\beta,mod} = \frac{\chi_{LT,\beta}}{f}$	k_{LT}	$\mu_0 = \frac{N_{\beta,Ed}}{\chi_{z,\beta} A f_y / \gamma_{M,\beta}} + \frac{k_{LT} M_{y,\beta,Ed}}{\chi_{LT,\beta} W_{pl,y} f_y / \gamma_{M,\beta}}$	$\theta_{a,cr}$ [°C]
20	0.859	0.426	0.523	1.000	0.958	0.529	575
575	1.029	0.509	0.443	0.981	0.876	0.554	568
568	1.021	0.506	0.446	0.984	0.883	0.554	568

c) In this paragraph the adaptation of Method 1 at high temperatures with factor f to determine the modified reduction factor, according to equation (7), (EC3 Method 1, f_i / f) will be used. The iterative process is summarized in the following table

θ [°C]	$\bar{\lambda}_{z,\theta}$	$\bar{\lambda}_{y,\theta}$	$\bar{\lambda}_{LT,\theta}$	$\chi_{z,\theta}$	$\chi_{y,\theta}$	$\chi_{LT,f,mod}$	$k_{yy,fi}$	$k_{zy,fi}$	$\mu_0 =$ max [(23) e (24)]	$\theta_{a,cr}$ [°C]
20	0.859	0.234	0.426	0.523	0.863	1.000	0.632	0.327	0.341	644
644	1.080	0.294	0.535	0.421	0.829	0.962	0.873	0.400	0.427	610
610	1.062	0.289	0.526	0.428	0.832	0.968	0.790	0.380	0.415	614
614	1.064	0.289	0.527	0.427	0.832	0.968	0.798	0.382	0.416	614

d) In this paragraph the adaptation of Method 2 at high temperatures with factor f to determine the modified reduction factor, according to equation (7), (EC3 Method 2, f_i / f) will be used. The iterative process is summarized in the following table

θ [°C]	$\bar{\lambda}_{z,\theta}$	$\bar{\lambda}_{y,\theta}$	$\bar{\lambda}_{LT,\theta}$	$\chi_{z,\theta}$	$\chi_{y,\theta}$	$\chi_{LT,f,mod}$	$k_{yy,fi}$	$k_{zy,fi}$	$\mu_0 =$ max [(23) e (24)]	$\theta_{a,cr}$ [°C]
20	0.859	0.234	0.426	0.523	0.863	1.000	0.402	0.860	0.500	585
585	1.038	0.282	0.514	0.439	0.836	0.977	0.410	0.626	0.482	591
591	1.046	0.284	0.518	0.435	0.835	0.974	0.410	0.609	0.479	591

CONCLUSIONS

It has been shown that the proposed methods for the lateral-torsional buckling of unrestrained steel beams at high temperatures, introduce significant improvements in the design curves of beam-columns under fire conditions.

Although the new proposal based on the method 1, in some cases, is not in the safe side when compared with the numerical results all the proposals presented here are in general in very good agreement with these results. In addition, if method 1 and method 2 are adopted, this has the advantage of using the same formulae at room temperature and at elevated temperature, being in line with the procedure which used to be in usage in the Eurocodes. These aspects should be considered when the new proposal for the resistance of beam-columns has to be chosen in the next revision of the Eurocode 3.

A design example has been solved adopting methods presented in this paper, which conclude that methods 1 and 2 give higher critical temperatures.

The study presented in this paper strongly recommends the use of one of these proposals in future versions of part 1-2 of the Eurocode 3.

REFERENCES

- [1] prEN 1993-1-1, *Eurocode 3: Design of Steel Structures – part 1-1: General rules and rules for buildings*, Stage 49, European Committee for Standardisation, Brussels, Belgium, 2003.
- [2] prEN 1993-1-2, *Eurocode 3: Design of Steel Structures – part 1-2: General Rules - Structural fire design*, European Committee for Standardisation, Brussels, Belgium, February 2003.
- [3] ENV 1993-1-1, *Eurocode 3: Design of Steel Structures – part 1-1: General rules and rules for buildings*, European Committee for Standardisation, Brussels, Belgium, 1992.
- [4] Vila Real, P.M.M., Lopes, N., Simões da Silva, L., Piloto, P., Franssen, J.-M., *Towards a consistent safety format of steel beam-columns: application of the new interaction formulae for ambient temperature to elevated temperatures*, Steel & Composite Structures, an International Journal, Techno-Press vol. 3, n. 6, p.p. 383-401, 2003.
- [5] Vila Real, P.M.M., Lopes, N., Simões da Silva, L., Franssen, J.-M., *Lateral-torsional buckling of unrestrained steel beams under fire conditions: improvement of EC3 proposal*, submitted to Computers & Structures, 2003.
- [6] Franssen, J.-M., "SAFIR. A Thermal/Structural Program Modeling Structures under Fire", Proc. NASCC conference, American Inst. for Steel Constr., Baltimore, April 2003.
- [7] ECCS – European Convention for Constructional Steelwork, *System, Ultimate Limit State Calculation of Sway Frames With Rigid Joints*, Technical Committee 8 – Structural Stability, Technical Working Group 8.2, first edition, 1984.
- [8] Boissonnade, N.; Jaspard, J.-P.; Muzeau, J.-P. and Villette, M., *New Interaction Formulae for Beam-Columns in Eurocode 3: The French-Belgian Approach*, J. of Constructional Steel Research 60(3-5), 421-431, 2004.
- [9] Greiner, R., *Background information on the beam-column interaction formulae at level 1*, ECCS TC 8 Ad-hoc working group on beam-columns paper No.TC8-2001, Technical University Graz, 19 September 2001.

A PRACTICAL APPROACH FOR PREDICTING THE CAPACITY OF STEEL COLUMNS WITH RESTRAINS OF WALL PANELS IN FIRE

G. Q. Li, Y. Z. Wang, M. F. Li^{*}
College of Civil Engineering, Tongji Univ. CHINA
GQLi@mail.tongji.edu.cn

ABSTRACT

Steel buildings are usually enclosed by wall panels, which may be connected to the columns. The attachment of wall panels to steel columns may affect the behavior of steel columns in two aspects. Firstly, the temperature increasing of steel columns with and without wall panel attachment due to fire are different. The wall panels may slow down the velocity of temperature increasing of steel columns in fire, but cause the non-uniform distribution of temperatures over the cross-section of steel columns. Secondly, the restrains of wall panels may normally raise the capacity of steel columns, which in turn raise the capacity of steel columns in fire.

For predicting the capacity of the axially-compressed steel column with restrains of wall panels in fire, the commercial FEM program, ANSYS, is employed to conduct numerical investigations on the behavior of the steel columns subjected to fire. The effects of load ratios, the number of restrains of wall panels along the height of columns and the temperature distribution over the cross-section of columns on the critical temperatures of axially-compressed steel columns are analyzed and discussed. The torsional instability phenomena of the columns under some conditions in fire is found. Based on the numerical investigations, a practical approach for checking the fire-resistant capacity of steel columns with attachment of wall panels is presented.

KEYWORDS: *steel structure, wall panels, column, fire-resistance, finite element method*

* Prof.