

THE IMPLEMENTATION OF THE REGULATIONS ON SOLAR COLLECTORS IN BUILDINGS

Maria Isabel Abreu* and Rui Oliveira

Polytechnic Institute of Bragança, Campus de S^{ta} Apolónia, Apartado 1134, 5301-875 Bragança, Portugal

** Corresponding Author, isabreu@ipb.pt*

Abstract

The use of solar energy constitutes a great concern of national and international bodies, as a result of a strategic policy towards green energy consumption. The Portuguese regulations on building thermal behaviour and energy efficiency, recently enacted by the Portuguese Government, in line with the European Union Directive 2002/91/CE, have introduced the obligatory use of solar collector technology for hot water production applied to new building projects and to some important retrofit works. To cope with the prescriptions of these regulations, the solar technology market is been growing and the Portuguese project designers and construction professionals are founding new challenges. The purpose of this study is to identify and analyse the major problems and initial impacts of the obligatory implementation of solar collector technology in buildings and provide contributions to improve solar energy use in the future. The results show that, as almost all new technology implementation, some obstacles have always to be faced initially.

Keywords: Solar Collector, Solar DWH, Building Thermal Regulations, Portugal.

1. Introduction

In residential buildings the energy for hot water production (DHW) contributes strongly to the final building consumptions of useful energy [1,2]. In the beginning of this decade, the Portuguese Program E4 – Energy Efficiency and Endogenous Energies have proposed an ambitious goal of 1 million m² of solar collector area in Portugal until 2010. To cope with this, it was implemented in 2001 by Portuguese Government the National Program *Solar Hot Water for Portugal* (IP-AQSpP) [3]. A more recent government effort is *The National Plan for de Energy Efficiency* (PNAEE), approved some months ago, that include important measures for buildings, ambitioning an improvement of 1% per year on energy efficiency [4]. The Portuguese new Thermal Regulations (RCCTE) opens to all constructions partners a new opportunity for implementing more strongly renewable energy technologies in buildings. Using solar hot water systems it can represent a saving of 20% on the total energy consume of a family in electricity and gas [3].

2. Methodology

The methodology used on this study consisted of a literature review on government and institutions publications and information, statistics and also interviews to professionals. Secondly, to complement the analysis, it was made simulations with the regulations methodology and with the official software for solar collectors, *Solterm*, with the consequent discussion of results.

3. The Portuguese Building Thermal Regulations on solar collectors

The new Thermal Regulations are applied to the all new residential and to some office buildings. Some cases of important retrofit work are also enclosed. The regulations are applied separately to

each autonomous zone of a building (each zone with an electricity energy meter). It establishes the obligatory use of solar collectors for hot water supply if the building has a sufficient solar exposure [2]. To have sufficient solar exposure means the building roof must not be shadowed during the period that begins two hours after sunrise and ends two hours before sunset, oriented between SE and SW. They also establish the obligatory use of a minimal of 1 m² of solar collector area (SCA) (aperture area) per each household of an autonomous zone (conventional nr of households = nr of bedrooms +1). This measure, recognised as a government policy effort to increase solar energy use in Portugal and meet strategic goals, immediately create some discussion in project designers about its cost-effectiveness. The law does not provide anything about the system efficiency and the project climate zone. There is only a regulation exception that allows breaking this minimal area. The value can be reduced to 50% of the total south-oriented roof area. Recently, the Portuguese Energy Agency (ADENE), that rules the Portuguese System for Energetic Certification of Buildings (SCE), clarified this situation and has allowed the use of a smaller collector area. Applying the regulations minimal area, the thermal project designer must proof that with less area can produces at least the same energy than a standard system (optical efficiency $\eta_0=69\%$ and loss coefficients $a_1=7,500 \text{ W}/(\text{m}^2.\text{K})$ and $a_2=0,014 \text{ W}/(\text{m}^2.\text{K}^2)$). The thermal regulations methodology uses the E_{solar} to quantify the energy produced by the solar collector system. The same methodology allows also using other renewable energy systems (E_{ren}). The total energy for heating water using conventional energy (N_{ac}) is calculated by the following equation (1).

$$N_{ac} = \left(\frac{Qa}{\eta a} - E_{\text{solar}} - E_{\text{ren}} \right) / A_p \quad (\text{kWh}/\text{m}^2.\text{year}) \quad (1)$$

The Qa value represents the total energy needs during a year for hot water heating and the ηa represents the equipment efficiency. The minimum value of ηa adopt by these regulations is 65%. The N_{ac} value is later comparable with a maximum value defined by regulations (N_a) and contributes also to the final value of total primary energy (N_{tc}) in kg of petroleum equivalent (2).

$$N_{tc} = 0,1 \left(\frac{N_{ic}}{\eta_i} \right) F_{p_{ui}} + 0,1 \left(\frac{N_{vc}}{\eta_v} \right) F_{p_{uv}} + N_{ac} F_{p_{ua}} \quad (\text{kgpe}/\text{m}^2.\text{year}) \quad (2)$$

Better values of E_{solar} , led to more reduced values of conventional energy consumptions therefore conducting to a more easily satisfaction of the requisites imposed by the thermal regulations. One important aspect can be noticed from this analysis, the equipments efficiency (η_i , η_v and η_a), for space heating, cooling and DHW became fundamental to achieve a good building thermal performance. Is not only important to have a strong envelope insulation to meet energy conservation, as the project designers were used to with the previous regulations, but now the efficient use of energy is a crucial aspect. Therefore, choosing the equipments efficiency became one of the mainly concerns that thermal project designers must be prepared for. Also, the selection of the conventional energy is fundamental, being electricity much more penalized than oil or gas ($F_p \text{ oil/gas} = 0,086 \text{ Kgpe}/\text{kWh}$ and $F_p \text{ electricity} = 0,290 \text{ Kgpe}/\text{kWh}$).

4. Portuguese buildings market on solar collectors

In the 80s decade there was made an important investment in solar collector technology in Portugal but some problems related with an insufficient developed technology and inexperienced installer firms have been created a negative image on the public eye. On the year of 2000, some studies estimated that Portugal had installed 239 500 m² of total collector area but many were not operational and never performed up to expectations. This value was quite distant from Greece (2

815 000 m²) and Turkey (750 000 m²) but quite equal to Spain (399 922 m²) and Italy (344 000 m²) [5]. The studies that have been elaborated by the Solar Thermal Energy Observatory since 2003, demonstrate that collectors market is been growing. The more recent study, from 2006, reveals that the collector area installed was 28 300 m², an increment of 49% relatively to the previous year, estimating that total area installed in Portugal was 253 000 of m² [6]. Small domestic systems represented 65% of the total market and multi-residential buildings were residual. It is true that solar collectors market is growing but is still very far from the 150 000 m² /year ambioned initially. Noticed that new regulations were enacted in 2006 and before that it was not obligatory to install solar collectors. We predicted that solar collector market is going to have the so long expected increment. It is proof that new regulations usually take a transition period of one or two years to be completely adopted by all parts.

5. Initial impacts of the implementation of the regulations on solar collectors

5.1. The education and training for project design professionals

Portuguese Civil Engineers are the legal responsible professionals for elaborate the water supply design projects. Until now they had to deal with simple equipments of hot water production but now they need to calculate a more complex and integrated system. After consulting a sufficient number of senior project design Civil Engineers they have responded that they are not very comfortable with this new technology and with all that is related with mechanical equipments. Traditional projects in the pass never forced them to know more about equipment subjects. Buildings are until now predominantly constructive but they are aware that intelligent and automatic buildings are a future inevitable reality. Despite there are some standard systems that function like a kit module, it is not sufficient to respond efficiently to the building design demand. In some cases, they are letting the design of solar collector system to be developed later by the installation firms with negative consequences on final building quality. Thus, it is absolutely essential that official institutions promote and stimulate even more training for these professionals. The process is been slow but some are making efforts to get training. Also, recent graduate Civil Engineers, who have just finishing theirs courses, faced almost the same problem mainly because many of the Institutions of Higher Education in Portugal still do not provide the required competencies on these subjects. In most of the courses there is still not an adequate and integrated group of curricular subjects that goes deep in these matters, providing the minimal competencies to accomplish sufficient professional practice in this area. Therefore, it would be necessary to make a great effort to introduce on the curricular course structures even more contents on those matters. And we can not forget other important aspect, as the firm's know-how is still not very high there is always a tendency to charge more for the installation and maintenance operations and give not so qualified engineering consultant. Now, these firms must be prepared to correspond to a more informed attitude from design professionals.

5.2 The building water supply design projects

The majority of the domestic water supply projects developed until now is based on very simply Domestic Hot Water (DHW) systems like electrically heated storage cylinder and gas or oil heating boilers. For Civil Engineers project designers the calculations were a quite simple task because they used to select the equipment without specific and demanding criteria. Nowadays, it is necessary to choose well the equipments to minimize its life-cycle cost because a minimum of three types of equipments must function together: the solar collector; the storage tank or cylinder and the backup equipment (e.g. condensing oil or gas heating boilers). The system operation is also

controlled by an automatic electronic unit. Not forgetting other system accessories, like pipes, pumps and valves [7,8]. The passive systems are commonly used on single residential buildings and they are more compact and easily mounted. But in multi residential buildings, there are several different consumers and it is necessary to think the most advantageous system installations option. Design professionals are dealing today with this dilemma because: they have little experience; they do not have much technical information to support their choices and there are not yet many multi-residential buildings with this technology in Portugal to learn with. Aware of this situation, a previous analysis for six system possible options (Table 1, Fig 1.) is presented next.

Table 1. Multi-residential buildings solar collector system options.

	Solar Collector	Water storage tank	Backup System	DWH	Operation and maintenance management
System 1	Individual	Individual	Individual Boiler		All expenses in charge of each autonomous zone
System 2	Individual	Individual	storage tank internal burner		
System 3	Collective	Individual	Individual boiler		A thermal energy meter for each autonomous zone or condominium management with a mensal rent
System 4	Collective	Individual	water storage tank internal burner		
System 5	Collective	Collective	Collective boiler		A thermal energy meter for each autonomous zone
System 6	Collective	Collective	water storage tank internal burner		

NOTE: Backup systems on electricity are not stimulated by regulations.

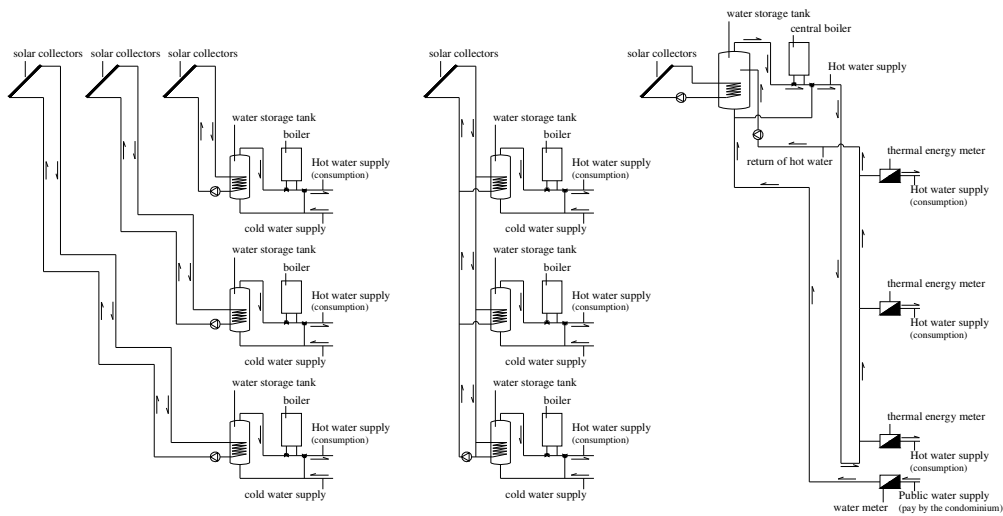

Fig 1. Multi-residential building solar collector system options.

Each of these design options has, in a preliminary perspective, positive and negative points.

Systems 1 and 2 – All equipments are individual - Advantages: self management of the system by each family (they adapt the system to their consumptions needs); minimal problems and conflicts with neighbours; the solar panels could be mounted with different tilt angles for each apartment adapted to their consumptions needs. **Disadvantages:** great number of water pipes and accessories, more building interior space needed and more heat losses; more home interior space to install equipments; high maintenance expenses for each family; if one home produces solar energy in excess it is not possible to redistribute it; in seasonal or not occupied spaces there is wasteful

production of energy; more complexity on the system mounting. **System 3 and 4 – Centralized solar collector - Advantages:** less initial investment ; better optimization of the collector area and of the solar south-oriented roof area; optimization of the captured solar energy and a rational distribution for all consumers; management and maintenance in charge of the building condominium administration; the energy of seasonal occupied or not occupied homes can be used by others; each individual consumer must adapt their consumptions needs to a collective system. **Disadvantages: more home** interior space to install equipments; heat exchanger in inverted system; the householders must pay a service not total adapted to their consumptions needs; some homes can take more profit from the solar collector system then others, it depends of the consumption needs schedule and habits. **System 5 and 6 - All equipments are sheared by all householders - Advantages:** less pipes and accessories; more reduced initial investment; no individual system maintenance; householders pays a total service of hot water supply; better optimization of the collector area and of the solar south-oriented roof area. **Disadvantages:** initial part of the system with inverted supply system (water supply starts from the first floors); complex management of the return water of the circuit into the water storage tank; variations on hot water temperatures can occur; lack of preparation of the condominium administrations firms to manage this service; system regulated to a constant level of water temperatures not adapted to consume households schedule with less energy efficient management; requires an adapted collective interior space for a high capacity water storage tank and backup equipments; the building structure must resist to higher loads due to the heavy equipments installed; the building architecture must be prepared for maintenance, repair and substitution of big equipments; reduced preparation of the local authorities to deal with this collective systems (taxes to pay etc); big size systems are more vulnerable to operation problems and damages.

The first two systems require some initial investment and in some cases can lead to collector areas that are not effectively used. The second group of systems seems to have more vantages due to the fact that can result in a better flexibility in the system management, made by both condominium administration and individual consumers. The last systems also have some advantages but represent a more vulnerable operating system.

5.3 The building design project documents and organization

It would be important to ensure that the homeowner or the condominium could have an operating and instructions manual, identifying equipment schemes, safety procedures, conservations and maintenance information about the solar collector system. It is fundamental to implement some control and management measures during the life-cycle time of these equipments, especially in summer, to guarantee durability, efficiency and therefore turning this investment cost-effective. The obligatory for solar collector brings to discussion the implementation of a repair and maintenance design project for residential buildings, with a wider scope then solar collector's subject. Residential building design is today facing fundamental changes and energy efficiency seems to be a start step to new design and property management approaches. The intelligent residential buildings concept, slightly inspired in a facility management concept in service buildings, is been slowly implemented in buildings. Monitoring and supervising devices as well as controlling and regulating systems in buildings appealed to the development of building automation. Other new building regulations are been enacted forward to get sustainable buildings, are examples: measures to better water supply and waste water management; more rigorous fire safety rules and security. A repair and maintenance design project turns to be essential and it is almost obvious that the obligatory use of solar collectors is going to accelerate this demand by local government authorities. Also, the health and safety design project must be adapted to this

new reality. A care should be taken to new risks, for example, the potential for excessive temperature and pressure in heat transfer fluids and stored water, the risk of Legionnaires' disease, working at height and electrical safety.

5.4 The cases of not obligatory implementation of solar collectors

In buildings placed on historical zones is not obligatory to install solar collectors if the south-oriented roof area available is going to create a negative visual impact. As we have seen before, the energy produced by the solar collector is very important to meet de RCCTE requirements. Therefore, in building rehabilitations, not installing solar collectors means the Nac value is going to be only supported by conventional energies. To understand better the implications of this in a real case it were made some calculations using a building example situated on a historical zone and in a soft Portuguese climate zone. It is a typical Portuguese building of approximately hundred years old with a wood roof structure and large stone walls. From the calculation made we concluded that without solar collectors three mainly measures hat to be taken: increment strongly the envelope insulation, choose the more energy efficient equipments as possible and also select equipments based on gas or oil supply and not on electricity. The results showed that only selecting envelope insulations widths of minimum 8-10 mm the building could be straight with the regulations. Notice, this width is still uncommon in Portuguese projects and is going to occupy some useful internal space joining the fact that typical stone exterior walls have already great widths. Another problem detected is that usually the conventional energy to select must be electricity because usually there is not available natural gas supply on these zones. It seems by this example, that these regulations look a little restrictive for buildings in historical zones.

Other case is that collectors are not obliged to be implemented when the building south-oriented roof is or is going to be in the future shadowed during the solar period mentioned in chapter 3. One of the future obstacles on the efficient implementation of solar collectors is the fact that there is a lack of policies and regulations on urban planning to give the minimal guarantees to building sun exposure. In some cases, is difficult to know for sure what kind of constructions are going to be authorized in the future near the project site. It is an important problem related with governmental territory planning strategies.

5.5 The number of householders in buildings

In Portugal 1/5 of buildings are occupied during only a part of the year [4]. Many cases of emigrant people and second house for holidays are example of this. In these cases, there are not regular consumptions and applying the regulations can originate a potential for excessive energy production. In some summer occupied homes the solar collector mounting tilt angle should be lower, above 35°, to maximize gains, maintaining the minimal area required [7]. Even another problem can be faced. The number of householders can vary widely. On this case, the system is over dimensioned and the equipment can not be cost-effective solution.

5.6 The integration on building architecture and construction

The collector's building integration is a new challenge for architects. It known that the recommendable optimal panel tilt angle is the local latitude angle plus ± 5 °C [7]. Portuguese continental territory has latitude angles between 36° and 42°. In horizontal roofs this angle it should be guaranteed by an independent structure. On pitched roofs the better choice was to follow the roof tilt angle but it should be south oriented and not always is like that. If this is the case, is necessary to mount an independent structure for the panels using the calculations tilt angle and south-orientation. The result is a strong and negative visual impact on building architecture. In

large panel areas, this solution even can result in more mounting panel area because some panels can more easily obstruct others. Some façade elements near the roof can make a good role on disguising this type of installation. If the roof is E and/or W oriented, the panels tilt angle need to be reduced to 25°C to guarantee not more than 5% of decrease in energy captured [7]. On this case, it could be difficult to use the roof tilt angle. But if the roof is south-oriented the decrease of energy captured by not using the optimal angle is insignificant comparing with the benefits in cost, panel safety to wind and building aesthetic [7]. The most current tilt angle roofs in Portuguese buildings vary between 20° and 50°. Are these angles proper to be adopted and still get solar collector energy? It were made simulations using the software *Solterm* (version 5.0) for a three bedrooms autonomous zone (4 householders/4m² of minimal SCA by regulations) and using a range of tilt angles between 20°-50°. Nine different Portuguese localities representing the nine continental climatic zones (locality -climatic zone) were selected: Águeda - I1V1, Albufeira - I1V2, Alandroal -I1V3, Alcobça - I2V1, Alcanena -I2V2, Castelo de Vide - I2V3, Celorico da Beira -I3V1, Bragança - I3V2 e Mirandela - I3V3. The other fixed parameters were:, a south oriented panel; a water storage tank with 200 l of capacity, a gas boiler and the solar collector standard defined by ADENE (chapter 3). It was observed from the E_{solar} values that for a same autonomous zone: the south localities are better to capture solar energy; even using a distant tilt angle from the optimal angle the south zones are still better then some north zones using the optimal angle; the best panels tilt angles are the latitude angle $\pm 5^\circ$; the maximal ΔE_{solar} between the optimal tilt angle and the lower angle (20°) is of 92 kWh/year that represents a not problematic value. Then, it seems acceptable for a pitched roof south orientated (including also SW and SE) to mount the collectors close to the tilt roof angle. But it would be even better that architects designed the roof tilt angles to mach with the optimal panel tilt angle previous calculated. Finally, it must not forget that some additional cares must also be in weatherproof all penetrations through the roof covering with suitable flashings and purpose-made tiles.

5.7 The application of the regulations minimal solar collector area

Following the new regulations, a three bedrooms autonomous zone must have a minimal collector area of 4 m² independently of the climate zone were is located. From the simulations results mentioned in chapter 5.4 we took the maximum value for E_{solar} that was 2083kWh/year in Alandroal (I1V3). What happens if we would like to reach on the others localities the same energy achieved in this one? The results have showed that just one location can reach almost that value with the minimal required area (4 m²), the other need more area (Fig 2.). It was made also calculations to see what the maximal SCA without having significant energy dissipations (overheating). This means that adopting just the regulation minimal collector area we can be wasting solar energy in some climatic zones that could have more potential. Of course we could adopt more efficient collectors to reach a higher value but, as it usual, many designers are going to follow strictly the imposed area and even will try to reduce it to save in costs and to achieve an easily integration in roofs. Calculating the minimal collector area for the rest of the localities (maintaining the same collector efficiency) to reach the same E_{solar} of Alandroal, resulted, in most of them, panel area increments of 0,5 m² to 2,5 m². In face of this, it seems it would be more effective to evolve the requirements to a minimal E_{solar} value per household adapted to different climatic zones or groups of zones. This would permit a better energy efficient /cost collector selection with not less energy efficiency management.

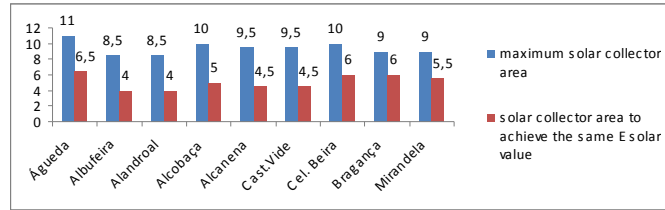

Fig 2. –Maximum SCA / SCA to achieve the same E_{solar} in the nine different localities.

6. Conclusions

Without any doubts, the new Thermal Regulations brings new challenges for the building design and construction industry activities and represents a start point to further advances in building sustainability and energy efficiency. After analyse the critical aspects concerning the implementation of solar collectors in Portugal, it was noticed that collectors market has conditions nowadays to grow towards a solid and income-producing market. But other conclusions could be taken. Portuguese Civil Engineers project designers are still not sufficient prepared to deal with this new technology although they are struggling to adapt to regulations and looking for training. By other means, high education institutions should adapt their Civil Engineer courses to give more competencies in these matters. Also, an adequate selection of the equipment system turns out to be a very important procedure to meet the regulations requirements. The building water supply design project, principally for multi-residential buildings, is facing important conceptual changes. Also, a repair and maintenance building design project, so long discussed and requested, turns to be even more essential. Architects have also here a very important role on the integration of solar collector on buildings as they could, among other things, design roof tilt angles adapted to solar collector optimal angles. But we must not forget we need government polices to provide minimal guarantees to building sun exposure. Relatively to the minimal regulations collector area, it seems that adopting just this area we can be wasting solar energy in some climatic zones that have more potential. A minimal E_{solar} value per household adapted to different climatic zones could guide better the designers to get more project design quality. Finally, we realize that, much work must be done but the changes imposed by new regulations should be seen as an opportunity to take the initial steps to more effective energy efficient construction in buildings.

References

- [1] European Union Directive 2002/91/CE of 4 of January 2003.
- [2] Portuguese Government, Decree Law 80/2006 of 4th April.
- [3] ADENE, INETI, SPES, APISOLAR, MEI, DGGE, Hot Water Program for Portugal (IP-AQSpP), www.aguaquentesolar.com.
- [4] DGGE & Ministry of Economy and Innovation (MEI), (2008) Portugal Efficiency 2015 – National Plan for Energy Efficiency (PNAEE), DGGE & MEI, Lisbon.
- [5] Weiss, W., Faninger, G, (2002) Solar Thermal Collector Market in IEA Member Countries, IEA Solar Heating & Cooling Programme, Austria.
- [6] Portuguese Observatory for Solar Thermal, (2003, 2004, 2005, 2006) Characterization of Solar Thermal in Portugal, ADENE & IP-AQSpP, Lisbon.
- [7] National Institution for Energy and Geology (DGGE), (2004) The Solar Collectors Use for Domestic Water Heating, DGGE & IP-AQSpP, Lisbon.
- [8] NHBC (2007), Guide to Renewable Energy, NHBC Technical, Amersham, Bucks, UK.