

PROGRESS IN MECHANICS AND MATERIALS IN DESIGN

J.F. Silva Gomes
Shaker A. Meguid
Editors

*Proceedings of the 7th International Conference on Mechanics and
Materials in Design, Albufeira/Portugal, 11-15 June 2017*

FEUP-INEGI
(2017)

About the Book:

Mechanics and Materials Science and Engineering have witnessed the most significant progress in recent years, and important and dramatic improvements in components design will continue to be made by the use of the latest advances in this field. During the last few decades the development of computer based techniques, as well as new experimental methods, nanotechnologies and nanomaterials, among many other material technological advances, added new dimension and perspectives to mechanical design and manufacturing of engineering systems, structures and components.

This volume contains the Extended Abstracts of papers accepted for presentation in the *M2D2017 - 7th International Conference on Mechanics and Materials in Design* held in Albufeira/Portugal, 11-15 June 2017. The book is complemented by an accompanying USB-card containing the full length papers.

M2D2017 is the seventh international gathering of a prestigious series of conferences coordinated by the International Scientific Committee of Mechanics and Materials in Design. This series of conferences is wholly devoted to advances in mechanics, materials, structural integrity and design. M2D2017 is sponsored by the University of Porto, the University of Toronto and the University of Algarve.

The conference attracted over 230 participants with 360 accepted submissions from 40 different countries. The conference themes which address novel and advanced topics in Mechanics and Materials in Design focused on computational mechanics, experimental mechanics, fatigue and fracture mechanics, composite and advanced materials, nanotechnologies and nanomaterials, tribology and surface engineering, mechanical design and prototyping, biomechanical applications, civil engineering applications, impact and crashworthiness, energy and thermo-fluid systems, and industrial engineering and management, among other topics

ISBN: 978-989-98832-6-0

Published by

INEGI-Instituto de Ciência e Inovação em Engenharia Mecânica e Gestão Industrial

Rua Dr Roberto Frias, 4200-465 Porto - Portugal

Telefone: +351 22 9578710; Email: inegi@inegi.up.pt

<http://www.inegi.up.pt/>

June, 2017

ISBN: 978-989-98832-6-0

N. DL: 423739/17

Printed by:

LusoImpress S.A.

Rua Venceslau Ramos, 28 - 4430-929 Avintes, Portugal

Tel: +351 22 787 73 20; Fax: +351 22 787 73 29

www.lusoimpress.com

All rights reserved. No part of this publication may be reproduced, stored in a retrieval system, or transmitted in any form or by any means, electronic, mechanical, optical, recording, or otherwise, without the prior written permission of the Editors

EDITORS' PREFACE

M2D2017 is the seventh international gathering of a prestigious series of conferences coordinated by the International Scientific Committee of Mechanics and Materials in Design. This series of conferences is wholly devoted to advances in mechanics, materials, structural integrity and design. M2D2017 is sponsored by the University of Porto, the University of Toronto and the University of Algarve. The conference attracted over 230 participants with 360 accepted submissions from 40 countries out of 416 submissions. These papers were presented in June 11-15, 2017 in the magnificent city of Albufeira/Algarve, Portugal. The conference themes which address novel and advanced topics in Mechanics and Materials in Design focused on computational mechanics, experimental mechanics, fatigue and fracture mechanics, composite and advanced materials, nanotechnologies and nanomaterials, tribology and surface engineering, mechanical design and prototyping, biomechanical applications, civil engineering applications, impact and crashworthiness, energy and thermo-fluid systems, and industrial engineering and management.

The conference also included an Open Forum on *The Challenges Facing Engineering Education*, where an expert panel with over 100 years of collective and active researchers and educators addressed the roles of professors that they meet, the obligations of their stakeholders and current challenges facing engineering education.

We believe that the meeting offered our delegates a forum for the dissemination of their recent work in mechanics and materials and their applications in engineering design, fostered research that integrates mechanics and materials in the design process, and promoted exchange of ideas and international co-operation among scientists and engineers in this important field of engineering.

We are particularly indebted to the authors and special guests for their presentations. Each of the more than 360 contributions offered opportunities for thorough discussions with the authors. Particularly, we acknowledge the excellent contributions of the participants, their innovative ideas and research directions, the novel modeling and simulation techniques, and the invaluable critical discussions. We are also indebted to the outstanding keynote speakers who highlighted the conference themes with their contributions. We also take this opportunity to thank the members of the International Scientific Committee, the members of the Advisory Committee and the reviewers for their time, effort and helpful suggestions.

We offer our sincere gratitude to the symposia organisers for their efforts and valuable contributions to the success of the event, and the local organising committee for attending to the conference demands and delegates needs.

All in all, M2D2017 was a great success and the credit must go to all the participants for their significant contributions and lively discussions, the keynote speakers for bridging the gap between the different disciplines and the organizing committee for an absolutely superb organization of the meeting in this magnificent city. To all of you, we offer our gratitude.

Given the rapidity with which science is advancing in all areas of mechanics and materials, the next conference in this series (Integrity, Reliability and Failure - IRF2018) will take place in Lisbon, the capital city of Portugal, in July 2018. Undoubtedly, we expect IRF2018 to be as stimulating and interesting as M2D2017, as evidenced by the excellent contributions offered in this current event. We look forward to seeing all of you in Lisbon in 2018.

Shaker A. Meguid and J.F. Silva Gomes
Albufeira / Portugal, June 2017

International Scientific Committee

Aben, H. (Estonia)	Meguid, S.A. (Canada)	Silva Gomes, J.F. (Portugal)
António, C.C. (Portugal)	Mileiko, S.T. (Russia)	Slocum, Alexander (USA)
Banks-Sills, L. (Israel)	Mines, R. (UK)	Sousa, Nelson (Portugal)
Barros, R.C. (Portugal)	Morimoto, Y. (Japan)	Tröster, T. (Germany)
Bremand, F. (France)	Ng, T.Y. (Singapore)	Umehara, N. (Japan)
Croccolo, D. (Italy)	Nowell, David (UK)	Van Hemelrijck, D. (Belgium)
Goldak, J. (Canada)	Owen, D.R.J. (UK)	Van Tooren, M. (USA)
Guagliano, M. (Italy)	Pieczyska, E. (Poland)	Weng, G. (USA)
Hess, Peter (Germany)	Reddy, J.N. (USA)	Xu, H. (China)
Kaleta, Jerzy (Poland)	Ruiz, Gonzalo (Spain)	Yoshino, Masahiko (Japan)
Kuhn, Erik (Germany)	Semenski, D. (Croatia)	Zhang, X. (China)

Advisory Committee

Alexopoulos, N. (Greece)	Gonçalves, Gil (Portugal)	Santos, Telmo (Portugal)
Azevedo, Alvaro (Portugal)	Kruszka, L. (Poland)	Seabra, Eurico (Portugal)
Baptista, João S. (Portugal)	Lino, Jorge (Portugal)	Seabra, Jorge (Portugal)
Bravi, Laura (Italy)	Liu, Yan (China)	Silva, Luis (Portugal)
Braz Cesar, M. (Portugal)	Lino, Jorge (Portugal)	Silva, Maria J. (Portugal)
Campos, Vicente (Portugal)	Machado, Carla (Portugal)	Sousa, Hipólito (Portugal)
Carvalho, Hélder (Portugal)	Meda, Alberto (Italy)	Sousa, Luisa (Portugal)
Correia, André (Portugal)	Mocko, W. (Poland)	Teixeira, Pâmies (Portugal)
Cunha, Alvaro (Portugal)	Morgado, Teresa (Portugal)	Turmanidze, Raul (Georgia)
Dinis, Lúcia (Portugal)	Murmura, Federica (Italy)	Varum, Humberto (Portugal)
Fonseca Elza. (Portugal)	Pappalettere, C. (Italy)	Wang, Changguo (China)
Gerasimov, A. (Russia)	Santos, Gilberto (Portugal)	Zelepugin, S. (Russia)

Institutional Sponsors

FEUP

*University of Porto
Portugal*

MADL

*University of Toronto
Canada*

UAlg/ISE

*University of Algarve
Portugal*

Co-Chairs

J.F. Silva Gomes (*U. Porto*)
Shaker A. Meguid (*U. Toronto*)

Organizing Committee

Carlos C. António, Catarina F. Castro, Clito F. Afonso, José M. Cirne
J. Reis Campos, M. Carlos Nunes, Mário A.P. Vaz, Paulo G. Piloto

Conference Secretariat

Eduarda Jesus, Lurdes Catalino

With the support of

ABREU-PCO, Professional Congress Organizer (<http://pco.abreu.pt>)
Mercatura Conference System (<http://www.mercatura.pt>)

SHEET METAL FORMING BY NUMERICAL SIMULATIONS: 2D AND 3D AXISYMMETRIC DEFORMATION OF A CYLINDRICAL PIECE

Kévin A. Mouta¹, Lucas D. Azevedo¹, Maria G. Fernandes², Elza M.M. Fonseca^{3(*)}

¹MSc Student, Polytechnique Institute of Bragança, Portugal

²PhD Student, INEGI, Faculty of Engineering, University of Porto, Porto, Portugal

³LAETA, INEGI, Polytechnique Institute of Bragança, Portugal

(*)Email: efonseca@ipb.pt

ABSTRACT

The aim of this work is conduct numerical simulations to verify the deep drawing process and the shape of the final stamping component of a simple profile of a sheet metal geometry. To evaluate the design of sheet metal forming, ANSYS program was used. A nonlinear dynamic explicit numerical model was developed using two different models: a 3D quarter and a 2D axisymmetric finite element model, due the geometry and loading conditions symmetry to reduce the computational time processing. The numerical simulations showed the shape deformation occurring after start the process and provided detailed quantitative information about expected weakness of the resulting piece.

Keywords: explicit dynamic, sheet metal, stamping.

INTRODUCTION

There are many industrial enterprises that use forming processes like deep drawing and stamping in order to produce sheet metal components with high productivity in large scale. In metal forming, a piece of material is plastically deformed to obtain the desired product with applications in different industrial areas (automobiles, trucks, airplanes, railway cars, locomotives, construction equipment, office furniture, office equipment...). Metal forming is one of the most important steps in manufacturing (Swadesh et al, 2014). In order to plastically deform a metal a force must be applied that will exceed the yield strength of the material. There are two different main classes of metal forming: the bulk and the sheet metal forming. Bulk deformation process is characteristic in that the work formed has a low surface area to volume ratio. The four basic bulk deformation processes are: rolling, forging, extrusion, wire and bar drawing. In sheet metal working, the metal being processed will have a high surface area to volume ratio. In this process cutting and forming operations are performed on relatively thin sheets of metal (0.4mm to 6mm). The three major categories are cutting, bending and drawing. The main advantages of the sheet metal parts are: high strength, good dimensional accuracy, good surface finish, relatively low cost for large quantities.

Until few years ago design of sheet metal forming was based on knowledge through work experience and expensive trial and error process. Nowadays the use of numerical simulations in different phases of the sheet metal forming process is performed using finite element analysis (Ranganath et al, 2012). Different codes are available for finite element analysis in metal forming such as Abaqus, Dynaform, Nike 2D, Ansys, etc. Also axisymmetric deformation of sheet metal blanks is used to represent a cylindrical piece made of flat metal

sheets, in pieces with axial symmetry. Different works demonstrated the relevance of this type of studies to prevent the occurrence of geometrical defects such as springback, wrinkling and surface appearance problems and to optimize various process variables, (Swadesh et al, 2014).

In this work, in order to assess the stamping performance of the cylindrical sheet metal piece, different numerical simulations were performed in the finite element code, starting from a Benchmark problem. In all simulations the complete die-face design composed of the punch, binder and the die geometry is assumed to be rigid components with a friction coefficient of 0.1. The blank material is the high strength steel of thickness 1mm. To increase the accuracy in the numerical simulations 3 different types of analysis were produced using: 3D quarter model with Solid 164 and Shell 163 elements; 3D quarter model only with Solid 164 elements and 2D axisymmetric model with Plane 162 element.

Figure 1 shows all meshes used for each model and the obtained final piece.

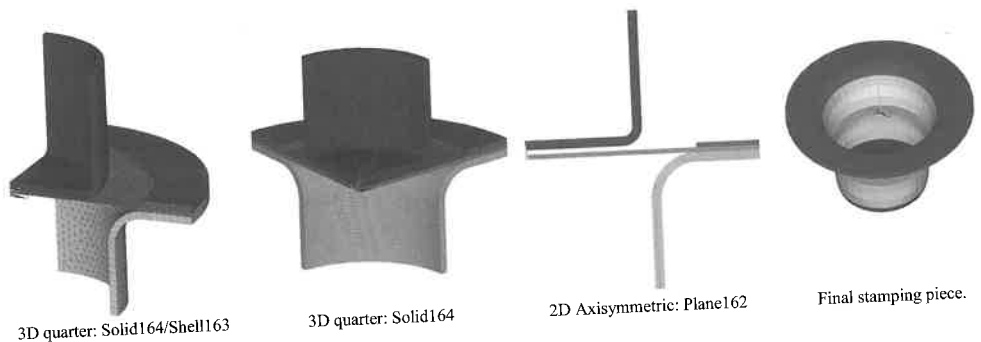

Fig. 1 - Different numerical simulations

RESULTS AND CONCLUSIONS

The results from the numerical simulations produced comparisons between all types of finite element models.

This study shows the finite element procedures for the sheet metal forming process and presents the performance of the use of axisymmetric conditions in the balance of the computational requirements against the desired accuracy of the results.

REFERENCES

- [1]-Ranganath J et al. Finite element method for simulation of a rectangular tank with an integral flange for automotive application. *International Journal of Engineering Research & Technology*, 2012, 1 (5), p. 1-10.
- [2]-Swadesh K S et al. Finite element simulation of ironing process under warm conditions. *Journal of Materials Research and Technology*, 2014, 3(1), p. 71-78.