

João Paulo Pais de Almeida

Anosov Diffeomorphisms, Renormalization and Tilings



Departamento de Matemática da Faculdade de Ciências
da Universidade do Porto
Novembro / 2012

João Paulo Pais de Almeida

Anosov Diffeomorphisms, Renormalization and Tilings



*Tese submetida à Faculdade de Ciências da Universidade do
Porto para obtenção do grau de Doutor em Matemática Aplicada*

Departamento de Matemática da Faculdade de Ciências
da Universidade do Porto

Novembro / 2012

Abstract

In this thesis, we prove a one-to-one correspondence between C^{1+} smooth conjugacy classes of circle diffeomorphisms that are C^{1+} fixed points of renormalization and C^{1+} conjugacy classes of Anosov diffeomorphisms whose Sinai-Ruelle-Bowen measure is absolutely continuous with respect to Lebesgue measure. Furthermore, we use ratio functions to parametrize the infinite dimensional space of C^{1+} smooth conjugacy classes of circle diffeomorphisms that are C^{1+} fixed points of renormalization. We introduce the notion of γ -tilings and we prove a one-to-one correspondence between (i) smooth conjugacy classes of Anosov diffeomorphisms, with an invariant measure absolutely continuous with respect to the Lebesgue measure, (ii) affine classes of γ -tilings and (iii) solenoid functions. The solenoid functions give a parametrization of the infinite dimensional space consisting of the mathematical objects described in the above equivalences.

Resumo

Nesta tese provamos a existência de uma correspondência bijetiva entre classes de conjugação C^{1+} diferenciáveis de difeomorfismos da circunferência que são pontos fixos de renormalização e classes de conjugação C^{1+} diferenciáveis de difeomorfismos de Anosov cuja medida SRB é absolutamente contínua relativamente à medida de Lebesgue. Mais ainda, usando funções rácio, exibimos uma parametrização do espaço de dimensão infinita das classes de conjugação C^{1+} diferenciáveis de difeomorfismos da circunferência que são pontos fixos de renormalização. Introduzimos a noção de γ -tiling e provamos a existência de uma correspondência bijetiva entre (i) classes de conjugação C^{1+} diferenciáveis de difeomorfismos de Anosov cuja medida SRB é absolutamente contínua relativamente à medida de Lebesgue, (ii) classes afins de γ -tilings e (iii) funções solenoide. As funções solenoide parametrizam os espaços de dimensão infinita dos objetos matemáticos descritos nas equivalências anteriores.

Contents

List of Figures	11
1 Introduction	12
2 Circle diffeomorphisms	14
2.1 The horocycle	15
2.2 Renormalization of a circle diffeomorphism	17
2.3 Markov map	19
2.4 Circle train-track	22
3 Anosov diffeomorphisms	26
3.1 Spanning leaf segments	28
3.2 Basic holonomies	28
3.3 Lamination atlas	29
3.4 Circle diffeomorphisms	29
3.5 Train-tracks	31
3.6 Markov maps	32
3.7 Exchange pseudo-group	33
3.8 Self-renormalizable structures	34
3.9 Circle diffeomorphisms and self-renormalizable structures	35

4	HR Structures	36
4.1	Basic holonomies and the atlas associated to a ratio function	37
4.2	Realized HR structures	38
4.3	Self-renormalizable structures and ratio functions	39
5	Solenoid functions	41
5.1	Hölder continuity of solenoid functions	42
5.2	Matching condition	42
5.3	Boundary condition	44
5.4	Solenoid functions	45
6	SRB and Gibbs measures	47
6.1	Duality of train-tracks	47
6.2	The SRB measures and their ratio decomposition	49
6.3	The dual affine structure on the stable lamination	54
6.4	The absolute continuity of the 2-dimensional SRB measure	57
6.5	Absolute continuity implies duality of the affine structures	59
7	Tilings	62
7.1	Realized γ -sequences	65
7.2	The γ -Fibonacci shift	68
7.3	Matching condition	70
7.4	Boundary condition	73
7.5	Exponentially fast γ -Fibonacci repetitive property	74
7.6	γ -Tilings	75
7.7	Proof of Theorem 7.1	77

7.8	Complete set of holonomies	78
7.9	Proof of Theorem 7.2	80
	References	81

List of Figures

2.1	The horocycle H and the chart $j : J \rightarrow \mathbb{R}$ in case (ii). The junction ξ of the horocycle is equal to $\xi = \pi_g(g(0)) = \pi_g(g^2(0)) = \pi_g(g^3(0))$	16
2.2	The horocycle H and the renormalization Rg of the circle diffeomorphism g topologically conjugate to g_γ with $\gamma = (\sqrt{5} - 1)/2$	17
2.3	The rigid Markov map M_{g_γ} , with respect to the atlas \mathcal{A}_{iso}^H , where $\gamma = (\sqrt{5} - 1)/2$. We represent by $\tilde{0}$ the point $\tilde{0} = \pi_{g_\gamma}(0)$ and by $\tilde{g}_\gamma^n(0)$ the points $\tilde{g}_\gamma^n(0) = \pi_{g_\gamma} \circ g_\gamma^n(0)$, for $n = 1, \dots, 4$	20
2.4	The charts used to prove that Mg is a local C^{1+} diffeomorphism when restricted to a $(l, 1)$ -arc for $l \in \{1, \dots, a + 1\}$. Here, $K^L = j_{3,1}(J_3^L)$, $K^R = j_{3,1}(J_1^R)$, $\tilde{K}^L = \tilde{j}(\tilde{J}^L)$ and $\tilde{K}^R = \tilde{j}(\tilde{J}^R)$	23
2.5	The charts used to prove that Mg is a local C^{1+} diffeomorphism when restricted to a (l, r) -arc for $r \in \{2, \dots, a + 1\}$ and $l \in \{1, \dots, a + 1\}$	24
3.1	The Markov partition and the dynamics of the Anosov automorphism $G_\gamma : \mathbb{T} \rightarrow \mathbb{T}$, with $\gamma = \gamma(2) = (\sqrt{5} - 1)/2$. Note that the image $G_\gamma(B)$ of the rectangle B is the dark gray rectangle and the image $G_\gamma(A)$ of the rectangle A is the whole light gray area.	27
3.2	A basic stable holonomy $\theta : \ell^u(x, R) \rightarrow \ell^u(z, R)$	28
3.3	The arc rotation map $g_G = \tilde{\theta}_G : \pi_{\mathbb{S}_G}(I) \rightarrow \pi_{\mathbb{S}_G}(J)$. We note that $\mathbb{S} = \pi_{\mathbb{S}_G}(I) = \pi_{\mathbb{S}_G}(J)$ and $\ell(x) = \pi_{\mathbb{S}_G}(x)$ is the spanning unstable leaf segment containing x	30
5.1	The matching condition for the solenoid function σ_G with $k = 2$ and $n = 5$	42

5.2	The Boundary condition for the realized solenoid function σ_G	46
6.1	The geometric relation between a cylinder C in T_G^ι and its dual. This is obtained by taking the ι' -leaf segments in C and applying a power of G_γ to get a rectangle that is the union of ι -leaf segments. Note how a nested sequence of cylinders corresponds to a backward orbit of cylinders in the original train-track.	49
6.2	This figure shows schematically the form of the various sets used in the proof of Theorem 6.1.	55
6.3	This figure shows how the dual ratio function is calculated. The three points are in the leaf x and their ratio is given by taking the limit of the ratios $\rho'_S(B_n)/\rho'_S(A_n)$	56
6.4	This figure shows the construction of the sets a_n and b_n in the proof of Lemma 6.6.	60
7.1	The map $i_S \circ \pi_S$	68
7.2	The location of the point y_i depending upon the Fibonacci decomposition of i	69
7.3	The matching condition for the sequence $(a_{G,i})_{i \in \mathbb{N}}$ for the three possible cases when $a = 1$: condition (i) corresponds to $I_{i-1} \in \mathbf{B}$ and $I_i \in \mathbf{A}$; condition (ii) corresponds to $I_{i-1} \in \mathbf{A}$ and $I_i \in \mathbf{B}$; condition (i) corresponds to $I_{i-1} \in \mathbf{A}$ and $I_i \in \mathbf{A}$;	72
7.4	A γ -sequence $(a_i)_{i \in \mathbb{L}}$	74
7.5	The exponentially fast γ -Fibonacci repetitive condition.	76
7.6	A complete set of unstable holonomies \mathcal{H}_G associated to the Markov partition \mathcal{M}_G	79

Chapter 1

Introduction

D. Sullivan and E. Ghys linked Anosov diffeomorphisms with diffeomorphisms of the circle through the observation that the holonomies of Anosov diffeomorphisms give rise to C^{1+} circle diffeomorphisms that are C^{1+} fixed points of renormalization (see Cawley [7]). Here, we prove that this observation gives a one-to-one correspondence between C^{1+} smooth conjugacy classes of circle diffeomorphisms that are C^{1+} fixed points of renormalization and C^{1+} conjugacy classes of Anosov diffeomorphisms with a Sinai-Ruelle-Bowen (SRB) measure that is absolutely continuous with respect to Lebesgue measure (see [3–5, 23, 26] and Chapter 13 of the book [36]).

Although in general an Anosov diffeomorphism admits a great abundance of invariant measures, there is at most one that is absolutely continuous with respect to Lebesgue measure and, when it exists, this measure is particularly significant for describing the statistical properties of the dynamics. Therefore the question of when an Anosov diffeomorphism has such a measure has been much studied. For an Anosov diffeomorphism $f : M \rightarrow M$ on a compact Riemannian surface M , Sinai [39] proved that the existence of such an absolutely continuous invariant measure is equivalent to the condition $|\det df^n(x)| = 1$ for every periodic point x with period n . Furthermore, Sinai [39] showed that for every C^{1+} Anosov diffeomorphism $f : M \rightarrow M$ there is a unique f -invariant probability measure ρ , called the *SRB measure*, such that for every open set $A \subset M$,

$$\lim_{n \rightarrow \infty} \lambda(f^{-n}A) = \rho(A)$$

where λ denotes the Lebesgue measure on M . Moreover, if f has an absolutely continuous invariant measure then this measure is the SRB measure. Since f^{-1} is

Anosov, f^{-1} also has a SRB measure which we denote by ρ^- . In general, $\rho^- \neq \rho$. However, Sinai [39] proved that $\rho^- = \rho$ is a necessary and sufficient condition for the existence of an absolutely continuous invariant measure. Pinto, Rand and Ferreira [36] relate the SRB measures with stable and unstable ratio functions by showing that the ratio functions determine the SRB measure conditional to stable and unstable local leaves and vice-versa.

On the other hand, the stable and unstable ratio functions associate an affine structure to each stable and unstable leaf in such a way that these vary Hölder continuously with the leaf. In this affine structure the Anosov diffeomorphism is affine on leaves and the basic holonomies are uniformly C^{1+} . Pinto and Rand [31] proved a one-to-one correspondence between C^{1+} conjugacy classes of Anosov diffeomorphisms on surfaces and pairs of stable and unstable ratio functions (see Cawley [7] for the construction of another moduli space for C^{1+} conjugacy classes of Anosov diffeomorphisms on surfaces using cohomology classes). Pinto, Rand and Ferreira [36] constructed an explicit dual operator that associates to each unstable ratio function r^u a dual stable ratio function r^s . Given an Anosov diffeomorphism we prove that the corresponding ratio functions r^s and r^u are dual if, and only if, the Anosov diffeomorphism has an invariant measure that is absolutely continuous with respect to Lebesgue measure (other related duality results appear in Cawley [7], Jiang [12], Llave [15] and Marco and Moriyon [18, 19]). Here, we prove an equivalence between ratio functions and C^{1+} circle diffeomorphisms that are C^{1+} fixed points of renormalization (see [4] and Chapter 13 of [36]).

Inspired in the works of Y. Jiang [13] and A. Pinto and D. Sullivan [37], we introduced the notion of γ -tiling. The γ -tilings record the infinitesimal geometric structure determined by the dynamics along the unstable leaf that is invariant by the Anosov diffeomorphism. We define the properties of the γ -tilings using the γ -Fibonacci decomposition of the natural numbers, instead of the dyadic decomposition, because the γ -Fibonacci decomposition has the advantage of encoding, in a natural way, the combinatorics determined by the Markov partition along the unstable leaf. Our goal is to exhibit a natural correspondence between γ -tilings, Anosov diffeomorphisms and solenoid functions (see [1, 24, 25]).

Chapter 2

Circle diffeomorphisms

In this chapter we link C^{1+} circle diffeomorphisms that are C^{1+} fixed points of renormalization with Markov maps (see [4, 5, 26, 36]).

Let us fix a natural number $a \in \mathbb{N}$ and let \mathbb{S} be a *counterclockwise oriented circle* homeomorphic to the circle $\mathbb{S}^1 = \mathbb{R}/(1 + \gamma)\mathbb{Z}$, where

$$\gamma = \gamma(a) = (-a + \sqrt{a^2 + 4})/2 = 1/(a + 1/(a + \dots)).$$

The key feature of γ is that it satisfies the relation $a\gamma + \gamma^2 = 1$. We note that if $a = 1$ then γ is the inverse of the golden number $(1 + \sqrt{5})/2$.

An *arc* in \mathbb{S} is the image of a non trivial interval I in \mathbb{R} by a homeomorphism $\alpha : I \rightarrow \mathbb{S}$. If I is closed (resp. open) we say that $\alpha(I)$ is a *closed* (resp. *open*) *arc* in \mathbb{S} . We denote by (a, b) (resp. $[a, b]$) the positively oriented open (resp. closed) arc on \mathbb{S} starting at the point $a \in \mathbb{S}$ and ending at the point $b \in \mathbb{S}$. A C^{1+} atlas \mathcal{A} in \mathbb{S} is a set of charts such that (i) every small arc of \mathbb{S} is contained in the domain of some chart in \mathcal{A} , and (ii) the overlap maps are $C^{1+\alpha}$ compatible, for some $\alpha > 0$.

Let \mathcal{A}_{iso} denote the affine atlas whose charts are isometries with respect to the usual norm in \mathbb{S}^1 . Let the *rigid rotation* $g_\gamma : \mathbb{S}^1 \rightarrow \mathbb{S}^1$ be the affine homeomorphism, with respect to the atlas \mathcal{A}_{iso} , with rotation number $\gamma/(1 + \gamma)$. A C^{1+} *circle diffeomorphism* is a triple $(g, \mathbb{S}, \mathcal{A})$ where $g : \mathbb{S} \rightarrow \mathbb{S}$ is a $C^{1+\alpha}$ diffeomorphism, with respect to the $C^{1+\alpha}$ atlas \mathcal{A} , for some $\alpha > 0$, and g is quasi-symmetric conjugate to the rigid rotation g_γ with respect to the atlas \mathcal{A}_{iso} . We denote by \mathcal{F} the set of all C^{1+} circle diffeomorphisms $(g, \mathbb{S}, \mathcal{A})$ and, in order to simplify the notation, we denote the C^{1+} circle diffeomorphism $(g, \mathbb{S}, \mathcal{A})$ by g . In particular, we denote the rigid rotation

$(g_\gamma, \mathbb{S}^1, \mathcal{A}_{iso})$ by g_γ .

2.1 The horocycle

Let us mark a point in \mathbb{S} that we will denote by $0 \in \mathbb{S}$, from now on. Let $S_0 = [0, g(0)]$ be the oriented closed arc in \mathbb{S} , with endpoints 0 and $g(0)$. For every $k \in \{0, \dots, a\}$, let $S_k = [g^k(0), g^{k+1}(0)]$ be the oriented closed arc in \mathbb{S} , with endpoints $g^k(0)$ and $g^{k+1}(0)$ and such that $S_k \cap S_{k-1} = \{g^k(0)\}$. Let $S_{a+1} = [g^{a+1}(0), 0]$ be the oriented closed arc in \mathbb{S} , with endpoints $g^{a+1}(0)$ and 0 .

We introduce an *equivalence relation* \sim in \mathbb{S} by identifying the $a+1$ points $g(0), \dots, g^{a+1}(0)$ and form the topological space $H(\mathbb{S}, g) = \mathbb{S} / \sim$. We take the orientation in H as the reverse of the orientation induced by \mathbb{S} . We call this oriented topological space the *horocycle* (see Figure 2.2) and we denote it by $H = H(\mathbb{S}, g)$. We consider the quotient topology in H . Let $\pi_g : \mathbb{S} \rightarrow H$ be the natural projection. The point

$$\xi = \pi_g(g(0)) = \dots = \pi_g(g^{a+1}(0)) \in H$$

is called the *junction* of the horocycle. For every $k \in \{0, \dots, a\}$, let $S_k^H = S_k^H(\mathbb{S}, g) \subset H$ be the projection by π_g of the closed arc S_k . Let $R\mathbb{S} = S_0^H \cup S_{a+1}^H$ be the *renormalized circle*. The horocycle H is the union of the renormalized circle $R\mathbb{S}$ with the circles S_k^H for every $k \in \{1, \dots, a\}$.

A *parametrization* in H is the image of a non trivial interval I in \mathbb{R} by a homeomorphism $\alpha : I \rightarrow H$. If I is closed (resp. open) we say that $\alpha(I)$ is a *closed* (resp. *open*) *arc* in H . A *chart* in H is the inverse of a parametrization. A *topological atlas* \mathcal{B} on the horocycle H is a set of charts $\{(j, J)\}$, on the horocycle, with the property that every small arc is contained in the domain of a chart in \mathcal{B} , i.e. for any open arc K in H and any $x \in K$ there exists a chart $\{(j, J)\} \in \mathcal{B}$ such that $J \cap K$ is a non trivial open arc in H and $x \in J \cap K$. A C^{1+} *atlas* \mathcal{B} in H is a topological atlas \mathcal{B} such that the overlap maps are $C^{1+\alpha}$ and have $C^{1+\alpha}$ uniformly bounded norms, for some $\alpha > 0$.

Let \mathcal{A} be a C^{1+} atlas on \mathbb{S} in which $g : \mathbb{S} \rightarrow \mathbb{S}$ is a C^{1+} circle diffeomorphism. We are going to construct a C^{1+} atlas \mathcal{A}^H on H that we call the *extended pushforward* $\mathcal{A}^H = (\pi_g)_* \mathcal{A}$ of the atlas \mathcal{A} on \mathbb{S} . If $x \in H \setminus \{\xi\}$ then there exists a sufficiently small open arc $J \subset H$ containing x and such that $\pi_g^{-1}(J)$ is contained in the domain of some chart (I, i) of \mathcal{A} . In this case, we define $(J, i \circ \pi_g^{-1})$ as a chart in \mathcal{A}^H . If $x = \xi$ and

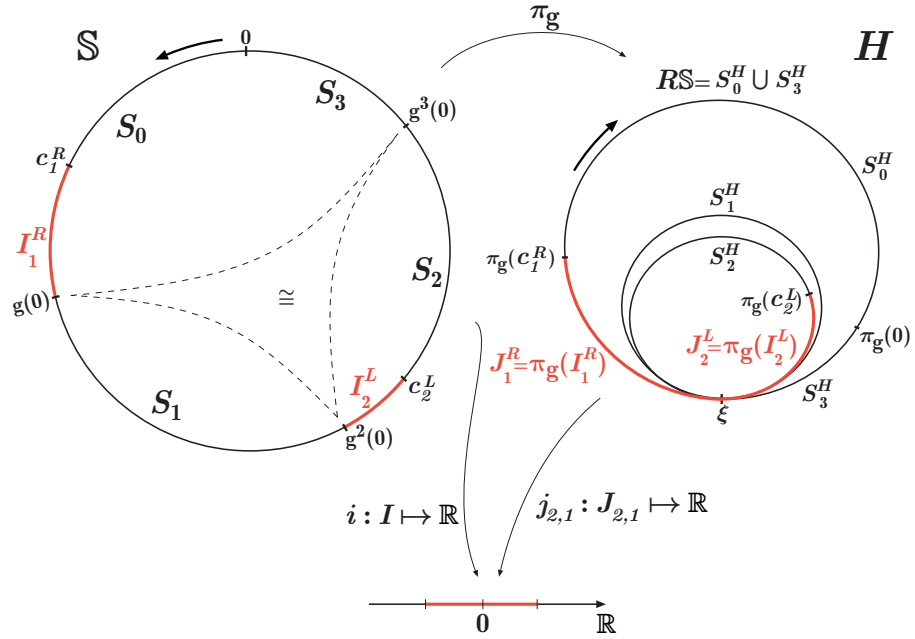

Figure 2.1: The horocycle H and the chart $j : J \rightarrow \mathbb{R}$ in case (ii). The junction ξ of the horocycle is equal to $\xi = \pi_g(g(0)) = \pi_g(g^2(0)) = \pi_g(g^3(0))$.

J is a small arc containing ξ , then either (i) $\pi_g^{-1}(J)$ is an arc in \mathbb{S} or (ii) $\pi_g^{-1}(J)$ is a disconnected set that consists of a union of two connected components.

In case (i), $\pi_g^{-1}(J)$ is connected it is contained in the domain of some chart $(I, i) \in \mathcal{A}$. Therefore we define $(J, i \circ \pi_g^{-1})$ as a chart in \mathcal{A}^H .

In case (ii), $\pi_g^{-1}(J)$ is a disconnected set that is the union of two connected arcs I_l^L and I_r^R of the form $I_l^L = (c_l^L, g^l(0))$ and $I_r^R = [g^r(0), c_r^R)$, respectively, for all $l, r \in \{1, \dots, a+1\}$. Let J_l^L and J_r^R be the arcs in H defined by $J_l^L = \pi_g(I_l^L)$ and $\pi_g(I_r^R)$ respectively. Then $J = J_l^L \cup J_r^R$ is an arc in H with the property that $J_l^L \cap J_r^R = \{\xi\}$, for every $l, r \in \{1, \dots, a+1\}$. We call such arc J a (l, r) -arc and we denote it by $J_{l,r}$. Let $j_{l,r} : J_{l,r} \rightarrow \mathbb{R}$ be defined by,

$$j_{l,r}(x) = \begin{cases} i \circ \pi_g^{-1}(x) & \text{if } x \in J_r^R \\ i \circ g^{r-l} \circ \pi_g^{-1}(x) & \text{if } x \in J_l^L \end{cases}.$$

Let $(I, i) \in \mathcal{A}$ be a chart such that $\pi_g(I) \supset J_{l,r}$. Then we define $(J_{l,r}, j_{l,r})$ as a chart in \mathcal{A}^H (see Figure 2.1). We call the atlas determined by these charts the *extended pushforward atlas of \mathcal{A}* and, by abuse of notation, we will denote it by $\mathcal{A}^H = (\pi_g)_* \mathcal{A}$.

2.2 Renormalization of a circle diffeomorphism

Let $g = (g, \mathbb{S}, \mathcal{A})$ be a C^{1+} circle diffeomorphism with respect to a C^{1+} atlas \mathcal{A} in \mathbb{S} . The *renormalization* of $g = (g, \mathbb{S}, \mathcal{A})$ is the triple $(Rg, R\mathbb{S}, R\mathcal{A})$, where (i) $R\mathbb{S}$ has the orientation of the horocycle H , i.e. the reversed orientation of the orientation induced by \mathbb{S} in $R\mathbb{S}$; (ii) the *renormalized atlas* $R\mathcal{A} = \mathcal{A}^H|_{R\mathbb{S}}$ is the set of all charts in \mathcal{A}^H with domains contained in $R\mathbb{S}$; and (iii) $Rg : R\mathbb{S} \rightarrow R\mathbb{S}$ is the continuous map given by (see Figure 2.2)

$$Rg(x) = \begin{cases} \pi_g \circ g^{a+1} \circ (\pi_g|_{S_0})^{-1}(x) & \text{if } x \in S_0^H \\ \pi_g \circ g \circ (\pi_g|_{S_{a+1}})^{-1}(x) & \text{if } x \in S_{a+1}^H \end{cases}.$$

For simplicity of notation, we will denote the renormalization $(Rg, R\mathbb{S}, R\mathcal{A})$ of a C^{1+} circle diffeomorphism g only by Rg .

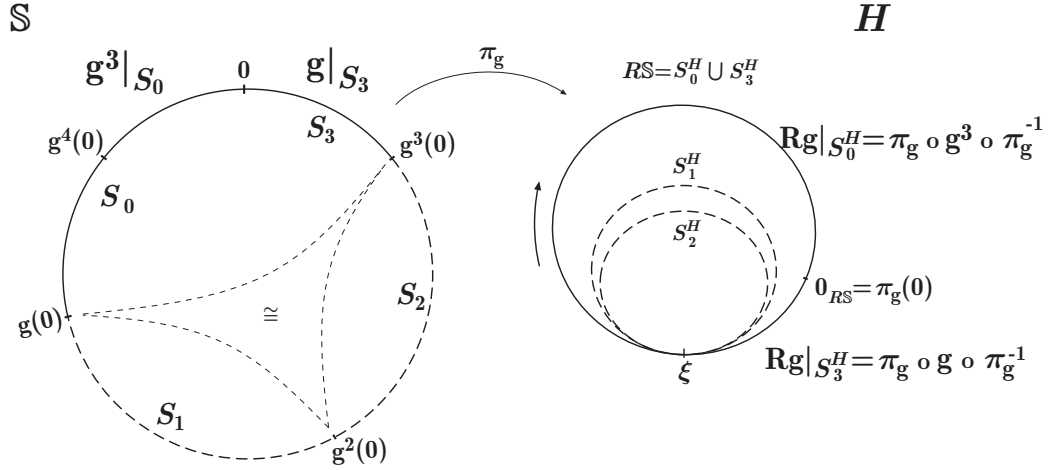

Figure 2.2: The horocycle H and the renormalization Rg of the circle diffeomorphism g topologically conjugate to g_γ with $\gamma = (\sqrt{5} - 1)/2$.

Lemma 2.1 *The renormalization Rg of a C^{1+} circle diffeomorphism g is a C^{1+} circle diffeomorphism. In particular, the renormalization Rg_γ of the rigid rotation is the rigid rotation g_γ .*

Proof. Let $g = (g, \mathbb{S}, \mathcal{A})$ be a C^{1+} circle diffeomorphism and let $Rg = (Rg, R\mathbb{S}, R\mathcal{A})$ be its renormalization. Observe that

$$(i) \quad Rg(S_0^H) = \pi_g(g^{a+1}(S_0));$$

$$(ii) \quad Rg(S_{a+1}^H) = \pi_g(g(S_{a+1}));$$

(iii) $Rg(\pi_g(0)) = \pi_g(g(0)) = \pi_g(g^{a+1}(0))$; and

(iv) $Rg(\pi_g(g(0))) = \pi_g(g^{a+2}(0))$, and so $Rg(\xi) = \pi_g(g^{a+2}(0))$.

Hence, $Rg : R\mathbb{S} \rightarrow R\mathbb{S}$ is a homeomorphism. Let us prove that Rg is a C^{1+} circle diffeomorphism. By construction of the atlas $R\mathcal{A}$ we have that the restrictions $Rg|_{\text{int}(S_0^H)}$ and $Rg|_{\text{int}(S_{a+1}^H)}$ are C^{1+} diffeomorphisms onto their images. Hence, it is enough to prove that the map Rg is a C^{1+} diffeomorphism onto its image for (a) a small arc $J \subset R\mathbb{S}$ containing 0 and for (b) a small arc $\tilde{J} \subset R\mathbb{S}$ containing ξ .

Let us prove case (a). Let $I_a = (a, 0] \subset S_{a+1}$ and $I_b = [0, b) \subset S_0$ be such that $J = \pi_g(I_a) \cup \pi_g(I_b)$. Let $\hat{I}_a = g(I_a)$ and $\hat{I}_b = g^{a+1}(I_b)$ and let $\hat{I} = \hat{I}_a \cup \hat{I}_b$. Hence $Rg(\pi_g(I_a)) = \pi_g(\hat{I}_a)$ and $Rg(\pi_g(I_b)) = \pi_g(\hat{I}_b)$. Let (I, i) be a chart in \mathcal{A} such that $I \supset I_a \cup I_b$. The chart $j_H : J \rightarrow \mathbb{R}$ is defined as follows:

(i) $j_H \circ \pi_g(x) = i(x)$, for $x \in I_a$ and

(ii) $j_H \circ \pi_g(x) = i(x)$, for $x \in I_b$.

Similarly, the chart $k_H : Rg(J) \rightarrow \mathbb{R}$ is defined as follows:

(i) $k_H \circ \pi_g(x) = k(x)$, for $x \in \hat{I}_a$ and

(ii) $k_H \circ \pi_g(x) = k(x)$, for $x \in \hat{I}_b$, where $k : I' \rightarrow \mathbb{R}$ is a chart in \mathcal{A} and $I' \supset \hat{I}$.

Hence, $k_H \circ Rg \circ i_H^{-1}(\pi_g(I_a)) = k \circ g \circ i^{-1}(I_a)$ and $k_H \circ Rg \circ i_H^{-1}(\pi_g(I_b)) = k \circ g^{a+1} \circ i^{-1}(I_b)$ and so Rg is a C^{1+} diffeomorphism in J .

Let us prove case (b). Consider $\tilde{I}_a = (a, \xi] \subset S_0$ and $\tilde{I}_b = [\xi, b) \subset S_{a+1}$ be such that $\tilde{I} = \pi_g(\tilde{I}_a) \cup \pi_g(\tilde{I}_b)$. Let $\tilde{I}'_a = g^{a+1}(\tilde{I}_a)$ and $\tilde{I}'_b = g(\tilde{I}_b)$ and let $\tilde{I}' = \tilde{I}'_a \cup \tilde{I}'_b$. Hence $Rg(\pi_g(\tilde{I}_a)) = \pi_g(\tilde{I}'_a)$ and $Rg(\pi_g(\tilde{I}_b)) = \pi_g(\tilde{I}'_b)$. Let $\tilde{J} = \pi_g(\tilde{I}_a) \cup \pi_g(\tilde{I}_b)$. The chart $j_H : \tilde{J} \rightarrow \mathbb{R}$ is defined as follows:

(i) $j_H \circ \pi_g(x) = i(x)$, for $x \in \tilde{I}_a$ and

(ii) $j_H \circ \pi_g(x) = i(x)$, for $x \in \tilde{I}_b$, where $i : I \rightarrow \mathbb{R}$ is a chart in \mathcal{A} such that $I \supset \tilde{I}$.

Similarly, the chart $k_H : Rg(\tilde{J}) \rightarrow \mathbb{R}$ is defined as follows:

- (i) $k_H \circ \pi_g(x) = k(x)$, for $x \in \tilde{I}'_a$ and
- (ii) $k_H \circ \pi_g(x) = k(x)$, for $x \in \tilde{I}'_b$, where $k : I' \rightarrow \mathbb{R}$ is a chart in \mathcal{A} and $I' \supset \tilde{I}'$.

Hence, $k_H \circ Rg \circ j_H^{-1}(\pi_g(\tilde{I}_a)) = k \circ g^{a+1} \circ j^{-1}(\tilde{I}_a)$ and $k_H \circ Rg \circ j_H^{-1}(\pi_g(\tilde{I}_b)) = k \circ g \circ j^{-1}(\tilde{I}_b)$ and so Rg is a C^{1+} diffeomorphism in \tilde{J} .

Let us consider the rigid rotation $g_\gamma : \mathbb{S}^1 \rightarrow \mathbb{S}^1$ with respect to the atlas \mathcal{A}_{iso} . By construction, Rg_γ is a rigid rotation in $R\mathcal{A}_{iso}$. We note that $|S_0| = \gamma$ and $|S_{a+1}| = \gamma^2$. Since the circle $R\mathbb{S}$ has the reverse orientation with respect to the orientation of \mathbb{S} , the rotation number of Rg_γ is equal to

$$\gamma^2/(\gamma + \gamma^2) = \gamma/(1 + \gamma).$$

Hence, Rg_γ is affine conjugate to g_γ . Since $g : \mathbb{S} \rightarrow \mathbb{S}$ is a C^{1+} circle diffeomorphism then there exist a unique quasi-symmetric homeomorphism $\psi : \mathbb{S} \rightarrow \mathbb{S}^1$ that conjugates g with the rigid rotation g_γ and such that $\psi(0) = [0] \in \mathbb{S}^1$. Hence, the map $\pi_{g_\gamma} \circ \psi \circ \pi_g^{-1}|_{R\mathbb{S}}$ is a quasi-symmetric conjugacy between Rg and Rg_γ . Since Rg_γ is affine conjugate to the rigid rotation, we get that Rg is also quasi-symmetric conjugate to the rigid rotation and so, we conclude that Rg is a C^{1+} circle diffeomorphism. \square

We note that, by Lemma 2.1, the map $R : \mathcal{F} \rightarrow \mathcal{F}$ given by $R(g) = Rg$ is well defined. The marked point $0 \in \mathbb{S}$ determines the marked point $0_{R\mathbb{S}} = \pi_g(0)$ in the circle $R\mathbb{S}$. Since Rg is homeomorphic to a rigid rotation, there exists a unique map $h : \mathbb{S} \rightarrow R\mathbb{S}$, with $h(0) = 0_{R\mathbb{S}}$, such that h conjugates g with Rg .

Definition 2.1 *If the conjugacy map $h : \mathbb{S} \rightarrow R\mathbb{S}$ is C^{1+} then we call g a C^{1+} fixed point of renormalization. We will denote by \mathcal{R} the set of all C^{1+} circle diffeomorphisms g that are C^{1+} fixed points of renormalization.*

We note that the rigid rotation g_γ is an affine fixed point of renormalization, with respect to the atlas \mathcal{A}_{iso} . Hence $g_\gamma \in \mathcal{R}$.

2.3 Markov map

Let $g = (g, \mathbb{S}, \mathcal{A})$ be a C^{1+} circle diffeomorphism, with respect to a C^{1+} atlas \mathcal{A} , and let $H = H(\mathbb{S}, g)$ be the horocycle determined by g . Let \mathcal{A}^H be the atlas on H that is the extended pushforward of the atlas \mathcal{A} . Let $\pi_g : \mathbb{S} \rightarrow H$ be the natural projection.

Let $h : \mathbb{S} \rightarrow R\mathbb{S}$ be the homeomorphism that conjugates g and Rg sending the marked point 0 of \mathbb{S} in the marked point $0_{R\mathbb{S}}$ of $R\mathbb{S}$.

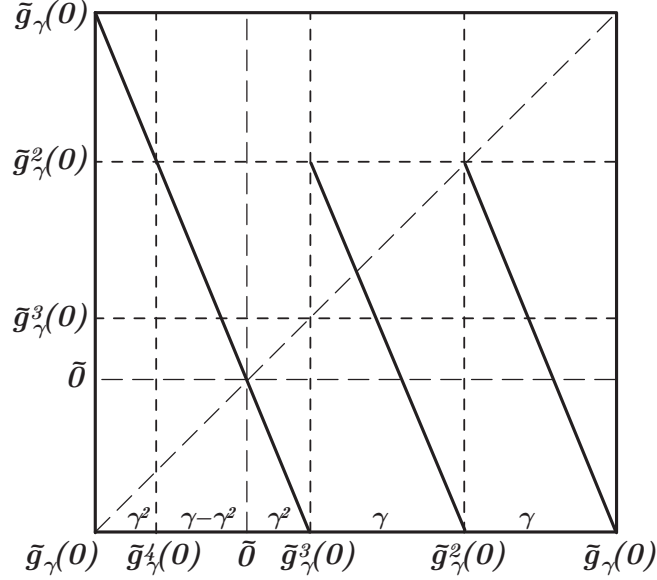

Figure 2.3: The rigid Markov map M_{g_γ} , with respect to the atlas \mathcal{A}_{iso}^H , where $\gamma = (\sqrt{5} - 1)/2$. We represent by $\tilde{0}$ the point $\tilde{0} = \pi_{g_\gamma}(0)$ and by $\tilde{g}_\gamma^n(0)$ the points $\tilde{g}_\gamma^n(0) = \pi_{g_\gamma} \circ g_\gamma^n(0)$, for $n = 1, \dots, 4$.

Definition 2.2 *The Markov map associated to the $C^{1+\alpha}$ circle diffeomorphism g , is the map $M_g : H \rightarrow H$ defined by*

$$M_g(x) = \begin{cases} \pi_g \circ h^{-1}(x) & \text{if } x \in R\mathbb{S} \\ \pi_g \circ h^{-1} \circ \pi_g \circ g^{a+1-k} \circ \pi_g^{-1}(x) & \text{if } x \in S_k^H, \text{ for } k = 1, \dots, a \end{cases}.$$

We note that

$$M_g(\pi_g \circ g^k(0)) = \pi_g \circ g^2(0) = \pi_g \circ g(0)$$

for every $k \in \{1, \dots, a+2\}$. We observe that the identification in H of $\pi_g \circ g(0)$ with $\pi_g \circ g^2(0)$ makes the Markov map M_g a local homeomorphism.

The *rigid Markov map* M_{g_γ} is the Markov map associated to the rigid rotation g_γ . The rigid Markov map M_{g_γ} is an affine map with respect to the atlas \mathcal{A}_{iso}^H (see Figure 2.3).

Theorem 2.1 *If g is a C^{1+} circle diffeomorphism then the Markov map M_g is a local C^{1+} diffeomorphism with respect to the atlas \mathcal{A}^H if, and only if, g is a C^{1+} fixed point of renormalization.*

Proof. Throughout the proof we denote $M = M_g$ and $\pi = \pi_g$. As in Section 2.1, let $J_{l,r}$ be a (l, r) arc and let J_l^L and J_r^R be the connected components of $J_{l,r}$ with the property that $J_{l,r} = J_l^L \cup J_r^R$ and $\{\xi\} = J_l^L \cap J_r^R$. Let I_l^L and I_r^R be the arcs in \mathbb{S} such that $J_l^L = \pi(I_l^L)$ and $J_r^R = \pi(I_r^R)$. For simplicity and without loss of generality, we can consider that $g^{1-l}(I_l^L) = I_1^L$ and $g^{1-r}(I_r^R) = I_1^R$, for every $l, r \in \{1, \dots, a+1\}$. Let $(J_{a+1,1}, j_{a+1,1})$ be a chart in $R\mathcal{A} = \mathcal{A}^H|_{R\mathbb{S}} \subset \mathcal{A}^H$ and let $(J_{l,r}, j_{l,r})$ be the chart in \mathcal{A}^H given by

$$j_{l,r}(x) = \begin{cases} j_{a+1,1} \circ \pi|_{I_{a+1}^L} \circ g^{a+1-l} \circ (\pi|_{I_l^L})^{-1}(x) & \text{if } x \in J_l^L \subset S_l^H \\ j_{a+1,1} \circ \pi|_{I_{a+1}^L} \circ g^{1-r} \circ (\pi|_{I_l^L})^{-1}(x) & \text{if } x \in J_r^R \subset S_{r-1}^H \end{cases}.$$

Since $J_l^L \subset S_l^H$, by construction of M , we have

$$\begin{aligned} M \circ j_{l,r}^{-1}|_{j_{l,r}(J_l^L)} &= \\ &= \left(\pi|_{S_0} \circ h^{-1} \circ \pi|_{I_{a+1}^L} \circ g^{a+1-l} \circ (\pi|_{I_l^L})^{-1} \right) \circ \pi|_{I_l^L} \circ g^{-(a+1-l)} \circ (\pi|_{I_{a+1}^L})^{-1} \circ j_{a+1,1}^{-1} \\ &= \pi|_{S_{a+1}} \circ h^{-1} \circ j_{a+1,1}^{-1}. \end{aligned} \tag{2.1}$$

Let $\tilde{J}^R = M(J_{a+1}^L) \subset S_0^H$. By the construction of the Markov map, we have that $\tilde{J}^R = M(J_l^L)$ for every $l \in \{1, \dots, a+1\}$. Since $J_1^R \subset S_0^H \subset R\mathbb{S}$, by construction of M , we have

$$M \circ j_{l,1}^{-1}|_{j_{l,1}(J_l^R)} = \pi|_{S_1} \circ h^{-1} \circ j_{a+1,1}^{-1}. \tag{2.2}$$

Let $\tilde{J}^L = M(J_1^R) \subset S_1^H$. Since $J_r^R \subset S_{r-1}^H$, for $r \geq 2$, we have

$$\begin{aligned} M \circ j_{l,r}^{-1}|_{j_{l,r}(J_r^R)} &= \\ &= \left(\pi|_{S_2} \circ h^{-1} \circ \pi|_{S_0} \circ g^{a+2-r} \circ (\pi|_{I_r^R})^{-1} \right) \circ \pi|_{I_r^R} \circ g^{r-1} \circ (\pi|_{I_1^R})^{-1} \circ j_{a+1,1}^{-1} \\ &= \pi|_{S_2} \circ h^{-1} \circ \pi|_{S_0} \circ g^{a+1} \circ (\pi|_{I_1^R})^{-1} \circ j_{a+1,1}^{-1} \\ &= \pi|_{S_2} \circ h^{-1} \circ Rg \circ j_{a+1,1}^{-1} \\ &= \pi|_{S_2} \circ g|_{S_1} \circ h^{-1} \circ j_{a+1,1}^{-1} \end{aligned} \tag{2.3}$$

Let $\hat{J}^L = M(J_2^R) \subset S_2^H$. By (2.2) and (2.3), we have that $\hat{J}^L = \pi \circ g \circ \pi^{-1}(\tilde{J}^L)$ and $\hat{J}^L = M(J_r^R)$ for $r \in \{2, \dots, a+1\}$. Let $\tilde{J} = \tilde{J}^L \cup \tilde{J}^R$ and $\hat{J} = \hat{J}^L \cup \tilde{J}^R$. Let the arcs \tilde{I}^L and \hat{I}^L in \mathbb{S} be given by $\tilde{J}^L = \pi(\tilde{I}^L)$ and $\hat{J}^L = \pi(\hat{I}^L)$. Let (\tilde{J}, \tilde{j}) be a chart in \mathcal{A}^H and let (\hat{J}, \hat{j}) be the chart in \mathcal{A}^H given by

$$\hat{j} = \begin{cases} \tilde{j} \circ \pi|_{\tilde{I}^L} \circ g^{-1} \circ (\pi|_{\hat{I}^L})^{-1}(x) & \text{if } x \in \hat{J}^L \\ \tilde{j}(x) & \text{if } x \in \tilde{J}^R \end{cases}.$$

Let us prove that if g is a C^{1+} circle diffeomorphism that is a fixed point of renormalization, then M is a C^{1+} local diffeomorphism. By hypothesis $h : \mathbb{S} \rightarrow R\mathbb{S}$ is a C^{1+} diffeomorphism with respect to the atlases \mathcal{A} and $R\mathcal{A}$. Hence, the restriction $M|_{\text{int}(S_k^H)}$ of the Markov map M to $\text{int}(S_k^H)$ is a local C^{1+} diffeomorphism with respect to the atlas \mathcal{A}^H . By (2.1) and (2.2), we have

$$\tilde{j} \circ M \circ j_{l,1}^{-1}|_{j_{l,1}^{-1}(J_1^R)} = \tilde{j} \circ \pi \circ h^{-1} \circ j_{a+1,1}^{-1}.$$

Hence, $M|_{J_{l,1}}$ is a local C^{1+} diffeomorphism (see Figure 2.4). For $r \geq 2$, by (2.1) and (2.2), we have

$$\hat{j} \circ M \circ j_{l,r}^{-1}|_{j_{l,r}^{-1}(J_{l,r})} = \tilde{j} \circ \pi \circ h^{-1} \circ j_{a+1,1}^{-1}.$$

Therefore, $M|_{J_{l,r}}$ is a C^{1+} local diffeomorphism (see Figure 2.5). Thus, we conclude that M is a C^{1+} local diffeomorphism.

Let us prove the converse. By hypothesis, M is a local C^{1+} diffeomorphism. Since $\pi \circ h^{-1}|_{R\mathbb{S}} = M_g$ and π is a local diffeomorphism onto its image, h^{-1} is a C^{1+} diffeomorphism in $R\mathbb{S}$ with respect to the atlases $R\mathcal{A}$ and \mathcal{A} . \square

The next remark follows from the proof of Theorem 2.1.

Remark 2.1 For every $x \in S_0^H$ take a small arc $J_x \subset S_0^H$ containing x . Let $I_x \subset \cup_{i=1}^{a+1} S_i$ be a small arc with the property that $\pi_g(I_x) = M_g(J_x)$. For every $r \in \{2, \dots, a+1\}$, we have that

$$\pi_g \circ g \circ (\pi_g|_{I_x})^{-1} \circ M_g(x) = M_g(g^r(x)).$$

2.4 Circle train-track

Similarly to the horocycle H introduced in Section 2.1 we construct the *circle train-track* \mathbb{T} . Let $(g, \mathbb{S}, \mathcal{A})$ be a C^{1+} circle diffeomorphism. We introduce an equivalence relation in \mathbb{S} by identifying $g(0)$ with $g^2(0)$ and form the oriented topological space $\mathbb{T}(\mathbb{S}, g) = \mathbb{S}/\sim$. We call $\mathbb{T} = \mathbb{T}(\mathbb{S}, g)$ the *circle train-track* and we consider the quotient topology in \mathbb{T} . Let $\pi_{\mathbb{T}} = \pi_{\mathbb{T},g} : \mathbb{S} \rightarrow \mathbb{T}$ be the natural projection. The point

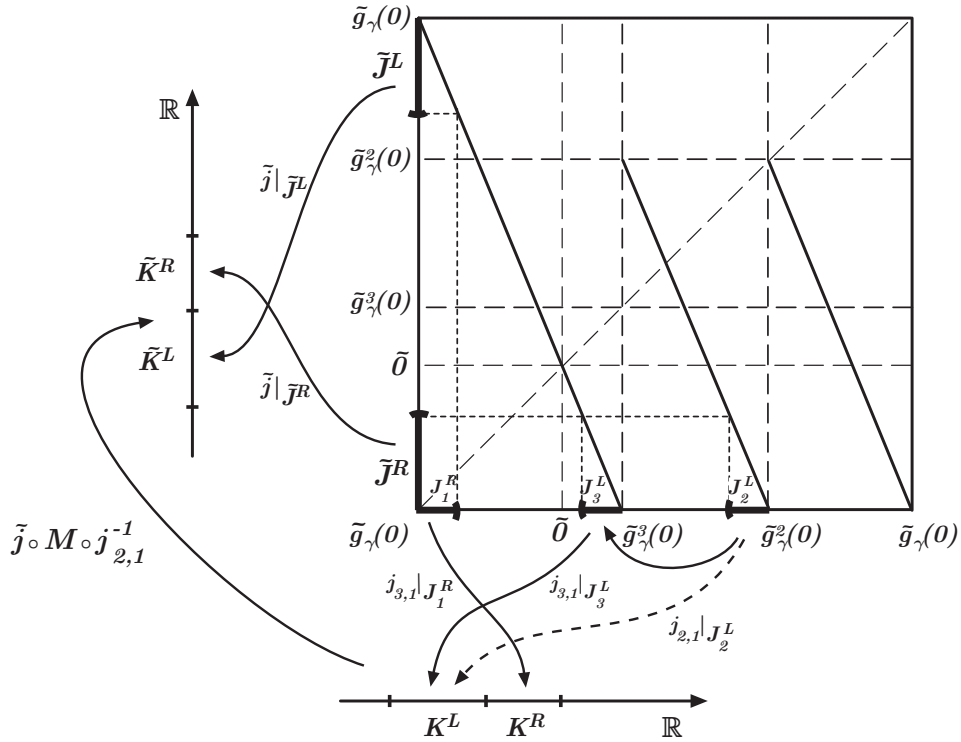

Figure 2.4: The charts used to prove that Mg is a local C^{1+} diffeomorphism when restricted to a $(l, 1)$ -arc for $l \in \{1, \dots, a + 1\}$. Here, $K^L = j_{3,1}(J_3^L)$, $K^R = j_{3,1}(J_1^R)$, $\tilde{K}^L = \tilde{j}(\tilde{J}^L)$ and $\tilde{K}^R = \tilde{j}(\tilde{J}^R)$.

$\xi_T = \pi_T(g(0)) = \pi_T(g^2(0)) \in T$ is called the *junction* of the circle train-track T . For every $k \in \{0, \dots, a + 1\}$, let $S_k^T = S_k^T(\mathbb{S}, g) \subset T$ be the projection by π_T of the closed arc $S_k \subset \mathbb{S}$, where the arcs S_k are the same as in Section 2.1.

A *parametrization* in T is the image of a non trivial interval I in \mathbb{R} by a homeomorphism $\alpha : I \rightarrow H$. If I is closed (resp. open) we say that $\alpha(I)$ is a *closed* (resp. *open*) arc in T . A *chart* in T is the inverse of a parametrization. A *topological atlas* \mathcal{B} on the circle train-track T is a set of charts $\{(j, J)\}$ with the property that every small arc is contained in the domain of a chart in \mathcal{B} , i.e. for any open arc K in T and any $x \in K$ there exists a chart $\{(j, J)\} \in \mathcal{B}$ such that $J \cap K$ is a non trivial open arc in T and $x \in J \cap K$. A C^{1+} atlas \mathcal{B} in T is a topological atlas \mathcal{B} such that the overlap maps are $C^{1+\alpha}$ and have $C^{1+\alpha}$ uniformly bounded norms, for some $\alpha > 0$.

Let \mathcal{A} be a C^{1+} atlas on \mathbb{S} in which $g : \mathbb{S} \rightarrow \mathbb{S}$ is a C^{1+} circle diffeomorphism. We are going to construct a C^{1+} atlas \mathcal{A}^T in the circle train-track that is the *extended pushforward* $\mathcal{A}^T = (\pi_T)_* \mathcal{A}$ of the atlas \mathcal{A} in \mathbb{S} .

circle train-track \mathbb{T} is the map $M_{\mathbb{T}} : \mathbb{T} \rightarrow \mathbb{T}$ defined by

$$M_{\mathbb{T}}(x) = \begin{cases} \pi_{\mathbb{T}} \circ h^{-1}(x) & \text{if } x \in S_0^{\mathbb{T}} \cup S_{a+1}^{\mathbb{T}} \\ \pi_{\mathbb{T}} \circ h^{-1} \circ \pi_{\mathbb{T}} \circ g^{-k} \circ \pi_{\mathbb{T}}^{-1}(x) & \text{if } x \in S_k^{\mathbb{T}}, \text{ for } k = 1, \dots, a \end{cases} .$$

Lemma 2.2 *Let g be a C^{1+} circle diffeomorphism. Let M_g and $M_{\mathbb{T}} = M_{\mathbb{T},g}$ be the Markov maps associated to g defined in the horocycle H and in the circle train-track \mathbb{T} , respectively. Let \mathcal{A}^H and $\mathcal{A}^{\mathbb{T}}$ be the extended pushforward atlases in H and \mathbb{T} of the atlas \mathcal{A} , respectively. The Markov map M_g is a local C^{1+} diffeomorphism in H if and only if $M_{\mathbb{T}}$ is a local C^{1+} diffeomorphism in \mathbb{T} .*

Proof. If the Markov map $M_{\mathbb{T}} : \mathbb{T} \rightarrow \mathbb{T}$, associated to the C^{1+} circle diffeomorphism g , is a local C^{1+} diffeomorphism then, by a similar argument as the one used in the proof of Theorem 2.1, we obtain that g is a C^{1+} fixed point of renormalization. Again, by Theorem 2.1, this implies that M_g is a local C^{1+} diffeomorphism in H . Now, let $\pi_{\mathbb{T},H} : \mathbb{T} \rightarrow H$ be the natural projection from \mathbb{T} to H . Then $\mathcal{A}^H = (\pi_{\mathbb{T},H})_* \mathcal{A}^{\mathbb{T}}$ and so, by the definition of $M_{\mathbb{T}}$ and the construction of $\mathcal{A}^{\mathbb{T}}$, we obtain that $M_{\mathbb{T}}$ is a local C^{1+} diffeomorphism in \mathbb{T} . \square

Putting together Theorem 2.1 and Lemma 2.2, we obtain the following Corollary.

Corollary 2.1 *If g is a C^{1+} circle diffeomorphism, then the Markov map $M_{\mathbb{T}}$ is a C^{1+} local diffeomorphism with respect to the atlas $\mathcal{A}^{\mathbb{T}}$ if, and only if, the diffeomorphism g is a C^{1+} fixed point of renormalization.*

Chapter 3

Anosov diffeomorphisms

In this chapter we are going to relate Anosov diffeomorphisms with self-renormalizable structures and C^{1+} circle diffeomorphisms that are C^{1+} fixed points of renormalization (see also Pinto, Rand and Ferreira [27, 34, 35]).

Let us fix a positive integer $a \in \mathbb{N}$ and consider the *Anosov automorphism* $G_\gamma : \mathbb{T} \rightarrow \mathbb{T}$ given by $G_\gamma(x, y) = (ax + y, x)$, where \mathbb{T} is equal to $\mathbb{R}^2 / (v\mathbb{Z} \times w\mathbb{Z})$ with $v = (\gamma, 1)$ and $w = (-1, \gamma)$ and $\gamma = \gamma(a)$ is as in Section 2. Let $\pi : \mathbb{R}^2 \rightarrow \mathbb{T}$ be the natural projection. Let \tilde{A} and \tilde{B} be the rectangles $[0, 1] \times [0, 1]$ and $[-\gamma, 0] \times [0, \gamma]$ respectively. A Markov partition \mathcal{M}_γ of G_γ is given by $A = \pi(\tilde{A})$ and $B = \pi(\tilde{B})$ (see Figure 3.1). The unstable manifolds of G_γ are the projection by π of the vertical lines in the plane, and the stable manifolds of G_γ are the projection by π of the horizontal lines in the plane.

A C^{1+} *Anosov diffeomorphism* $G : \mathbb{T} \rightarrow \mathbb{T}$ is a $C^{1+\alpha}$ diffeomorphism, with $\alpha > 0$, such that (i) G is topologically conjugate to G_γ ; (ii) the tangent bundle has a $C^{1+\alpha}$ uniformly hyperbolic splitting into a stable direction and an unstable direction (see [38]). We denote by \mathcal{G} the set of all such C^{1+} Anosov diffeomorphisms with an invariant measure that is absolutely continuous with respect to the Lebesgue measure.

Throughout this thesis we will use the following notation: we use ι to denote an element of the set $\{s, u\}$ of the stable and unstable superscripts and ι' to denote the element of $\{s, u\}$ that is not ι . In the main discussion we will often refer to objects which are qualified by ι such as, for example, an ι -leaf. This means a leaf which is a leaf of the stable lamination if $\iota = s$ or the unstable lamination if $\iota = u$. In general the meaning should be quite clear.

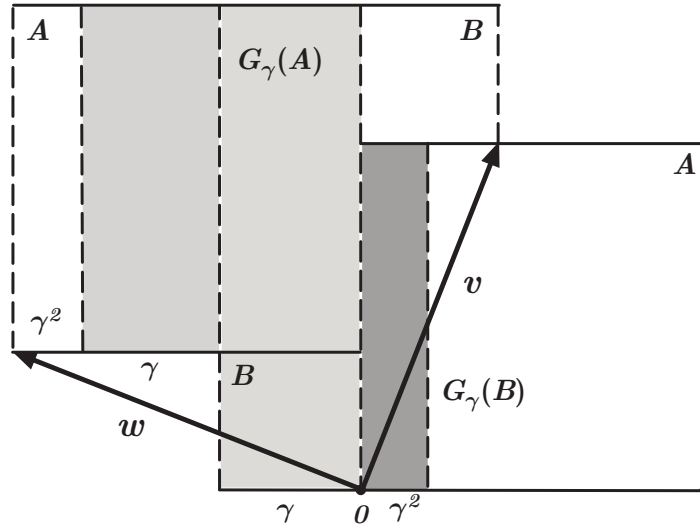

Figure 3.1: The Markov partition and the dynamics of the Anosov automorphism $G_\gamma : \mathbb{T} \rightarrow \mathbb{T}$, with $\gamma = \gamma(2) = (\sqrt{5} - 1)/2$. Note that the image $G_\gamma(B)$ of the rectangle B is the dark gray rectangle and the image $G_\gamma(A)$ of the rectangle A is the whole light gray area.

If h is the topological conjugacy between G_γ and G , then a Markov partition \mathcal{M}_G of G is given by $h(A)$ and $h(B)$. Let $d = d_\rho$ be the distance on the torus \mathbb{T} , determined by a Riemannian metric ρ . For $\iota \in \{s, u\}$, we define the map $G_\iota = G$ if $\iota = u$, or $G_\iota = G^{-1}$ if $\iota = s$. Given $x \in \mathbb{T}$, we denote the local ι -manifolds through x by

$$W^\iota(x, \varepsilon) = \{y \in \mathbb{T} : d(G_\iota^{-n}(x), G_\iota^{-n}(y)) \leq \varepsilon, \text{ for all } n \geq 0\}.$$

By the Stable Manifold Theorem (see [38]), these sets are respectively contained in the stable and unstable immersed manifolds

$$W^\iota(x) = \bigcup_{n \geq 0} G_\iota^n(W^\iota(G_\iota^{-n}(x), \varepsilon_0))$$

which are the image of $C^{1+\alpha}$ immersions $\kappa_{\iota, x} : \mathbb{R} \rightarrow \mathbb{T}$, for some $0 < \alpha \leq 1$ and some small $\varepsilon_0 > 0$. An *open* (resp. *closed*) ι -leaf segment I is defined as a subset of $W^\iota(x)$ of the form $\kappa_{\iota, x}(I_1)$ where I_1 is an open (resp. closed) subinterval (non-empty) in \mathbb{R} . An ι -leaf segment is either an open or closed ι -leaf segment. The *endpoints* of an ι -leaf segment $I = \kappa_{\iota, x}(I_1)$ are the points $\kappa_{\iota, x}(u)$ and $\kappa_{\iota, x}(v)$ where u and v are the endpoints of I_1 . The *interior* of an ι -leaf segment I is the complement of its boundary. A map $c : I \rightarrow \mathbb{R}$ is an ι -leaf chart of an ι -leaf segment I if c is a homeomorphism onto its image.

3.1 Spanning leaf segments

One can find a small enough $\varepsilon_0 > 0$, such that for every $0 < \varepsilon < \varepsilon_0$ there is $\delta = \delta(\varepsilon) > 0$ with the property that, for all points $w, z \in \mathbb{T}$ with $d(w, z) < \delta$, $W^u(w, \varepsilon)$ and $W^s(z, \varepsilon)$ intersect in a unique point that we denote by

$$[w, z] = W^u(w, \varepsilon) \cap W^s(z, \varepsilon).$$

A *rectangle* R is a subset of \mathbb{T} which is (i) closed under the bracket, i.e. $x, y \in R \Rightarrow [x, y] \in R$, and (ii) proper, i.e. it is the closure of its interior in \mathbb{T} . If ℓ^u and ℓ^s are respectively unstable and stable closed leaf segments intersecting in a single point then we denote by $[\ell^u, \ell^s]$ the set consisting of all points of the form $[w, z]$ with $w \in \ell^u$ and $z \in \ell^s$. We note that $[\ell^u, \ell^s]$ is a rectangle. Conversely, given a rectangle R , for each $x \in R$ there are closed unstable and stable leaf segments of \mathbb{T} , $\ell^u(x, R) \subset W^u(x)$ and $\ell^s(x, R) \subset W^s(x)$ such that $R = [\ell^u(x, R), \ell^s(x, R)]$. The leaf segments $\ell^s(x, R)$ and $\ell^u(x, R)$ are called *spanning stable* and *spanning unstable leaf segments*, respectively.

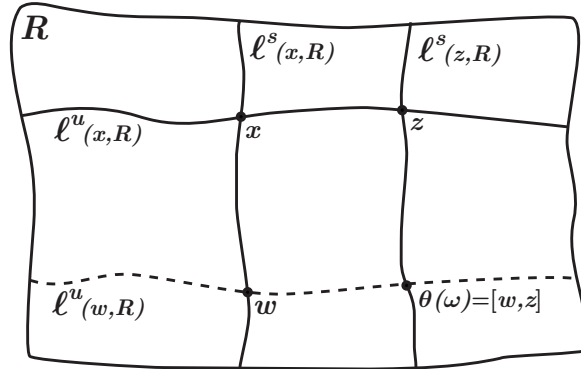

Figure 3.2: A basic stable holonomy $\theta : \ell^u(x, R) \rightarrow \ell^u(z, R)$.

3.2 Basic holonomies

Suppose that x and z are two points inside any rectangle R of \mathbb{T} . Let $\ell^s(x, R)$ and $\ell^s(z, R)$ be two spanning stable leaf segments of R containing, respectively, x and z . We define the map $\theta : \ell^s(x, R) \rightarrow \ell^s(z, R)$ by $\theta(w) = [w, z]$ (see Figure 3.2). Such maps are called the *basic stable holonomies*. They generate the pseudo-group of all stable holonomies. Similarly, we can define the *basic unstable holonomies*.

3.3 Lamination atlas

The *stable lamination atlas* $\mathcal{L}^s(G, \rho)$, determined by a Riemannian metric ρ , is the set of all maps $e : I \rightarrow \mathbb{R}$, where e is an isometry between the induced Riemannian metric on the stable leaf segment I and the Euclidean metric on the reals. We call the maps $e \in \mathcal{L}^s$ the *stable lamination charts*. Similarly, we can define the *unstable lamination atlas* $\mathcal{L}^u(G, \rho)$. By Theorem 2.1 in [30], the basic stable and unstable holonomies are C^{1+} with respect to the lamination atlas $\mathcal{L}^s(G, \rho)$.

3.4 Circle diffeomorphisms

Let $G \in \mathcal{G}$ be a C^{1+} Anosov diffeomorphism with an invariant measure absolutely continuous with respect to the Lebesgue measure and topologically conjugate to the Anosov automorphism G_γ by a homeomorphism h . For each Markov rectangle R , let t_R^s be the set of all spanning unstable leaf segments of R . By the local product structure, one can identify t_R^s with any spanning stable leaf segment $\ell^s(x, R)$ of R . We form the space \mathbb{S}_G by taking the disjoint union $\bigsqcup_{h(A)} t_{h(A)}^s \sqcup \bigsqcup_{h(B)} t_{h(B)}^s$, where $h(A)$ and $h(B)$ are the Markov rectangles of the Markov partition \mathcal{M}_G , and identifying two points $I \in t_R^s$ and $J \in t_{R'}^s$ if (i) $R \neq R'$, (ii) the unstable leaf segments I and J are unstable boundaries of Markov rectangles, and (iii) $\text{int}(I \cap J) \neq \emptyset$. Topologically, the space \mathbb{S}_G is a *counterclockwise oriented circle*. Let $\pi_{\mathbb{S}_G} : \bigsqcup_{R \in \mathcal{M}_G} R \rightarrow \mathbb{S}_G$ be the natural projection sending $x \in R$ to the point $\ell^u(x, R)$ in \mathbb{S}_G .

Let $I_{\mathbb{S}}$ be an arc in \mathbb{S}_G and I a leaf segment such that $\pi_{\mathbb{S}_G}(I) = I_{\mathbb{S}}$. The chart $i : I \rightarrow \mathbb{R}$ in $\mathcal{L}^s(G, \rho)$ determines a *circle chart* $i_{\mathbb{S}} : I_{\mathbb{S}} \rightarrow \mathbb{R}$ for $I_{\mathbb{S}}$ given by $i_{\mathbb{S}} \circ \pi_{\mathbb{S}_G} = i$. We denote by $\mathcal{A}^s(\mathbb{S}_G, G, \rho)$ the set of all circle charts $i_{\mathbb{S}}$ determined by charts i in $\mathcal{L}^s(G, \rho)$. Given any circle charts $i_{\mathbb{S}} : I_{\mathbb{S}} \rightarrow \mathbb{R}$ and $j_{\mathbb{S}} : J_{\mathbb{S}} \rightarrow \mathbb{R}$, the overlap map

$$j_{\mathbb{S}} \circ i_{\mathbb{S}}^{-1} : i_{\mathbb{S}}(I_{\mathbb{S}} \cap J_{\mathbb{S}}) \rightarrow j_{\mathbb{S}}(I_{\mathbb{S}} \cap J_{\mathbb{S}})$$

is equal to $j_{\mathbb{S}} \circ i_{\mathbb{S}}^{-1} = j \circ \theta \circ i^{-1}$, where $i = i_{\mathbb{S}} \circ \pi_{\mathbb{S}_G} : I \rightarrow \mathbb{R}$ and $j = j_{\mathbb{S}} \circ \pi_{\mathbb{S}_G} : J \rightarrow \mathbb{R}$ are charts in $\mathcal{L}^s(G, \rho)$, and

$$\theta : i^{-1}(i_{\mathbb{S}}(I_{\mathbb{S}} \cap J_{\mathbb{S}})) \rightarrow j^{-1}(j_{\mathbb{S}}(I_{\mathbb{S}} \cap J_{\mathbb{S}}))$$

is a basic stable holonomy. By Theorem 2.1 in Pinto and Rand [30], there exists $\alpha > 0$ such that, for all circle charts $i_{\mathbb{S}}$ and $j_{\mathbb{S}}$ in $\mathcal{A}^s(\mathbb{S}_G, G, \rho)$, the overlap maps

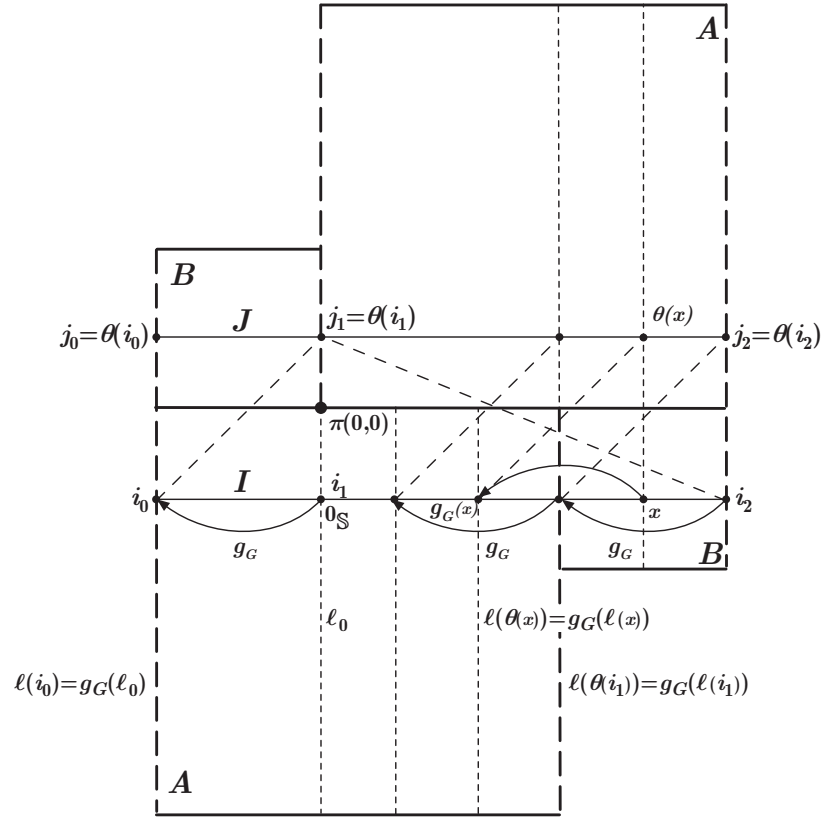

Figure 3.3: The arc rotation map $g_G = \tilde{\theta}_G : \pi_{\mathbb{S}_G}(I) \rightarrow \pi_{\mathbb{S}_G}(J)$. We note that $\mathbb{S} = \pi_{\mathbb{S}_G}(I) = \pi_{\mathbb{S}_G}(J)$ and $\ell(x) = \pi_{\mathbb{S}_G}(x)$ is the spanning unstable leaf segment containing x .

$j_{\mathbb{S}} \circ i_{\mathbb{S}}^{-1} = j \circ \theta \circ i^{-1}$ are $C^{1+\alpha}$ diffeomorphisms with a uniform bound in the $C^{1+\alpha}$ norm. Hence, $\mathcal{A}^s(\mathbb{S}_G, G, \rho)$ is a C^{1+} atlas.

Suppose that I and J are stable leaf segments and $\theta : I \rightarrow J$ is a holonomy map such that, for every $x \in I$, the unstable leaf segments with endpoints x and $\theta(x)$ cross once, and only once, a stable boundary of a Markov rectangle. We define the *arc rotation map* $\tilde{\theta}_G : \pi_{\mathbb{S}_G}(I) \rightarrow \pi_{\mathbb{S}_G}(J)$, associated to θ , by $\tilde{\theta}_G(\pi_{\mathbb{S}_G}(x)) = \pi_{\mathbb{S}_G}(\theta(x))$ (see Figure 3.3). By Theorem 2.1 in Pinto and Rand [30] there exists $\alpha > 0$ such that the holonomy $\theta : I \rightarrow J$ is a $C^{1+\alpha}$ diffeomorphism, with respect to the C^{1+} lamination atlas $\mathcal{L}^s(G, \rho)$. Hence, the arc rotation maps $\tilde{\theta}_G$ are C^{1+} diffeomorphisms, with respect to the C^{1+} atlas $\mathcal{A}(G, \rho)$.

Lemma 3.1 *There is a well-defined C^{1+} circle diffeomorphism g_G , with respect to the C^{1+} atlas $\mathcal{A}^s(\mathbb{S}_G, G, \rho)$, such that $g|_{\pi_{\mathbb{S}_G}(I)} = \tilde{\theta}_G$, for every arc rotation map $\tilde{\theta}_G$. In*

particular, if G_γ is the Anosov automorphism, then g is the rigid rotation g_γ , with respect to the isometric atlas $\mathcal{A}^s(\mathbb{S}_{G_\gamma}, G_\gamma, E)$, where E corresponds to the Euclidean metric in the plane.

Proof. Let us consider the Anosov automorphism G_γ and the lamination atlas $\mathcal{L}_{iso} = \mathcal{L}^s(G_\gamma, E)$. Let $\mathcal{A}_{iso} = \mathcal{A}^s(\mathbb{S}_{G_\gamma}, G_\gamma, E)$ be the atlas on \mathbb{S}_{G_γ} determined by \mathcal{L}_{iso} , where \mathbb{S}_{G_γ} is as above. The overlap maps of the charts in \mathcal{A}_{iso} are translations, and the arc rotation maps $\tilde{\theta}_{G_\gamma} : \pi_{\mathbb{S}_{G_\gamma}}(I) \rightarrow \pi_{\mathbb{S}_{G_\gamma}}(J)$, as defined above, are also translations, with respect to the charts in \mathcal{A}_{iso} . Furthermore, the rigid circle rotation $g_\gamma : \mathbb{S}_{G_\gamma} \rightarrow \mathbb{S}_{G_\gamma}$, with respect to the atlas \mathcal{A}_{iso} , has the property that $g_\gamma|_{\pi_{\mathbb{S}_{G_\gamma}}(I)} = \tilde{\theta}_{G_\gamma}$. Hence, for every Anosov diffeomorphism G , let $h : \mathbb{T} \rightarrow \mathbb{T}$ be the topological conjugacy between G_γ and G . Let $g : \mathbb{S}_G \rightarrow \mathbb{S}_G$ be the map determined by $g \circ \pi_G \circ h(x) = g_\gamma \circ \pi_{G_\gamma}(x)$, with rotation number $\gamma/(1 + \gamma)$. Since the arc rotation maps $\tilde{\theta}_G = \pi_{\mathbb{S}_G}(I) \rightarrow \pi_{\mathbb{S}_G}(J)$ are C^{1+} , with respect to the atlas $\mathcal{A}(G, \rho)$ and $g|_{\pi_{\mathbb{S}_G}(I)} = \tilde{\theta}_G$, we obtain that g is a C^{1+} diffeomorphism. \square

3.5 Train-tracks

Train-tracks are the optimal leaf-quotient spaces on which the stable and unstable Markov maps induced by the action of G on leaf segments are local homeomorphisms.

Let $G \in \mathcal{G}$ be a C^{1+} Anosov diffeomorphism. Let h be the homeomorphism that conjugates G with G_γ . We recall that, for each Markov rectangle R , t_R^s denotes the set of all spanning unstable leaf segments of R and, by the local product structure, one can identify t_R^s with any spanning stable leaf segment $\ell^s(x, R)$ of R . We form the space T_G^s by taking the disjoint union $\bigsqcup t_{h(A)}^s \bigsqcup t_{h(B)}^s$, where $h(A)$ and $h(B)$ are the Markov rectangles of the Markov partition \mathcal{M}_G and identifying two points $I \in t_R^s$ and $J \in t_{R'}^s$ if (i) the unstable leaf segments I and J are unstable boundaries of Markov rectangles and (ii) $\text{int}(I \cap J) = \emptyset$. This space is called the *stable train-track* and it is denoted by T_G^s . Similarly, we define the *unstable train-track* T_G^u .

Let $\pi_{T_G^s} : \bigsqcup_{R \in \mathcal{M}_G} R \rightarrow T_G^s$ be the natural projection sending the point $x \in R$ to the point $\ell^u(x, R)$ in T_G^s . A *topologically regular point* I in T_G^s is a point with a unique preimage under $\pi_{T_G^s}$ (i.e. the preimage of I is not a union of distinct unstable boundaries of Markov rectangles). If a point has more than one preimage by $\pi_{T_G^s}$, then we call it a *junction* and we denote it by j^s . Hence, there is only one junction.

A chart $i : I \rightarrow \mathbb{R}$ in $\mathcal{L}^s(G, \rho)$ determines a *train-track chart* $i_T : I_T \rightarrow \mathbb{R}$ for I_T given by $i_T \circ \pi_{T_G^s} = i$. We denote by $\mathcal{A}^s(T_G^s, G, \rho)$ the set of all train-track charts i_T determined by charts i in $\mathcal{L}^s(G, \rho)$. Given any train-track charts $i_T : I_T \rightarrow \mathbb{R}$ and $j_T : J_T \rightarrow \mathbb{R}$ in $\mathcal{A}^s(T_G^s, G, \rho)$, the overlap map

$$j_T \circ i_T^{-1} : i_T(I_T \cap J_T) \rightarrow j_T(I_T \cap J_T)$$

is equal to $j_T \circ i_T^{-1} = j \circ \theta \circ i^{-1}$, where $i = i_T \circ \pi_{T_G^s} : I \rightarrow \mathbb{R}$ and $j = j_T \circ \pi_{T_G^s} : J \rightarrow \mathbb{R}$ are charts in $\mathcal{L}(G, \rho)$, and

$$\theta : i^{-1}(i_T(I_T \cap J_T)) \rightarrow j^{-1}(j_T(I_T \cap J_T))$$

is a basic stable holonomy. By Theorem 2.1 in Pinto and Rand [30], there exists $\alpha > 0$ such that, for all train-track charts i_T and j_T in $\mathcal{A}^s(T_G^s, G, \rho)$, the overlap maps $j_T \circ i_T^{-1} = j \circ \theta \circ i^{-1}$ have $C^{1+\alpha}$ diffeomorphic extensions with a uniform bound in the $C^{1+\alpha}$ norm. Hence, $\mathcal{A}^s(T_G^s, G, \rho)$ is a $C^{1+\alpha}$ atlas on T_G^s .

3.6 Markov maps

The (*stable*) *Markov map* $m_s = m_{s,G} : T_G^s \rightarrow T_G^s$ is the mapping induced by the action of G on spanning unstable leaf segments and it is defined as follows: if $I \in T_G^s$, then $m_s(I) = \pi_{T_G^s}(G(I))$ is the spanning unstable leaf segment containing $G(I)$. This map m_s is a local homeomorphism because G sends short stable leaf segments homeomorphically onto short stable leaf segments. Similarly, we can define the (*unstable*) *Markov map* $m_u = m_{u,G} : T_G^u \rightarrow T_G^u$.

A *stable leaf primary cylinder* of a Markov rectangle R is a spanning stable leaf segment of R . For $n \geq 1$, a *stable leaf n -cylinder* of R is a stable leaf segment I such that (i) $G^n I$ is a stable leaf primary cylinder of a Markov rectangle $R'(I) \in \mathcal{M}_G$; (ii) $G^n(\ell^u(x, R)) \subset R'(I)$ for every $x \in I$, where $\ell^u(x, R)$ is a spanning unstable leaf segment of R .

For $n \geq 1$, a n -cylinder is a subset C of T_G^s or T_G^u such that, for $\iota \in \{s, u\}$, $m_\iota^n C$ is in $A^\iota = t_{h(A)}^\iota$ or in $B^\iota = t_{h(B)}^\iota$ and m_ι^n is a homeomorphism of $\text{int } C$ onto $\text{int } m_\iota^n C$. Hence, a n -cylinder is the projection into T_G^ι of a ι -leaf n -cylinder segment. Thus, each Markov rectangle in \mathbb{T} projects in a unique primary ι -leaf segment in T_G^ι .

Given a topological chart (e, U) on the train-track T_G^s and a train-track segment $C \subset U$, we denote by $|C|_e$ the length of $e(C)$. We say that m_s has *bounded geometry*

in a C^{1+} atlas \mathcal{B} , if there is $\kappa_1 > 0$ such that, for every n -cylinder C_1 and n -cylinder C_2 with a common endpoint with C_1 , we have $\kappa_1^{-1} < |C_1|_e/|C_2|_e < \kappa_1$, where the lengths are measured in any chart (e, U) of the atlas \mathcal{B} such that $C_1 \cup C_2 \subset U$.

Lemma 3.2 *Given a C^{1+} Anosov diffeomorphism $G \in \mathcal{G}$, with respect to a C^{1+} atlas \mathcal{A} , the Markov map $m_s = m_{s,G}$ is a C^{1+} local diffeomorphism and has bounded geometry with respect to the C^{1+} atlas $\mathcal{A}^s(\mathbb{T}_G^s, G, \rho)$.*

Proof. Let I_T be an arc in \mathbb{T}_G^s and let I be a leaf segment such that $\pi_{\mathbb{T}_G^s}(I) = I_T$. Let $J_T = m_s(I_T)$ and J be the leaf segments such that $G(I) = J$. Let $i_T : I_T \rightarrow \mathbb{R}$ and $j_T : J_T \rightarrow \mathbb{R}$ be the charts given by $i_T \circ \pi_{\mathbb{T}_G^s} = i$ and $j_T \circ \pi_{\mathbb{T}_G^s} = j$. Since $j_T \circ m_s \circ i_T^{-1} = j \circ G^{-1} \circ i^{-1}$, we obtain that $j_T \circ m_s \circ i_T^{-1}$ is a local C^{1+} diffeomorphism and so m_s is a local C^{1+} diffeomorphism with respect to the atlas $\mathcal{A}^s(\mathbb{T}_G^s, G, \rho)$. Furthermore, since G^{-1} is uniformly expanding along stable leaves, m_s has bounded geometry. \square

3.7 Exchange pseudo-group

Suppose that I and J are stable leaf segments and let $\theta : I \rightarrow J$ be a basic stable holonomy. The map $\tilde{\theta}_T : \pi_{\mathbb{T}_G^s}(I) \rightarrow \pi_{\mathbb{T}_G^s}(J)$ given by $\tilde{\theta}_T \circ \pi_{\mathbb{T}_G^s} = \pi_{\mathbb{T}_G^s} \circ \theta$ is a *stable exchange map*. The set of all stable exchange maps is the *stable exchange pseudo-group* and will be denoted by E_G .

Lemma 3.3 *The elements of the exchange pseudo-group E_G are C^{1+} diffeomorphisms with respect to the C^{1+} atlas $\mathcal{A}^s(\mathbb{T}_G^s, G, \rho)$.*

Proof. Let I and J be two stable leaf segments and let $\theta : I \rightarrow J$ be a basic stable holonomy. Let $I_T = \pi_{\mathbb{T}_G^s}(I)$ and $J_T = \pi_{\mathbb{T}_G^s}(J)$. Let $i : I \rightarrow \mathbb{R}$ and $j : J \rightarrow \mathbb{R}$ be two charts in the stable lamination atlas $\mathcal{L}^s(G, \rho)$ and let $i_T : I_T \rightarrow \mathbb{R}$ and $j_T : J_T \rightarrow \mathbb{R}$ the charts in $\mathcal{A}^s(\mathbb{T}_G^s, G, \rho)$ given by $i_T \circ \pi_{\mathbb{T}_G^s} = i$ and $j_T \circ \pi_{\mathbb{T}_G^s} = j$. By Theorem 2.1 in Pinto and Rand [30] the map $j \circ \theta \circ i^{-1}$ is a C^{1+} diffeomorphism. Since $j_T \circ \tilde{\theta}_T \circ i_T^{-1} = j \circ \theta \circ i^{-1}$ we get that the stable exchange map $\tilde{\theta}_T : \pi_{\mathbb{T}_G^s}(I) \rightarrow \pi_{\mathbb{T}_G^s}(J)$ is a C^{1+} diffeomorphism. \square

3.8 Self-renormalizable structures

A C^{1+} structure $\mathcal{S} = \mathcal{S}(T_G^s)$ on T_G^s is a maximal set of charts on T_G^s such that all the charts are C^{1+} compatible. Let \mathcal{B} be a $C^{1+\alpha}$ atlas of \mathcal{S} , for some $\alpha > 0$, and let $\mathcal{B}|_{\mathbb{S}_G}$ be the set of charts in \mathcal{B} that are also charts in \mathbb{S}_G . We note that a $C^{1+\alpha}$ atlas \mathcal{B} in T_G^s determines a unique C^{1+} structure $\mathcal{S}(T_G^s, \mathcal{B})$ on T_G^s .

Definition 3.1 *A C^{1+} structure $\mathcal{S}(T_G^s, \mathcal{B})$ on T_G^s is a stable self-renormalizable structure if it has the following properties:*

- (i) *The Markov map $m_s = m_{s,G}$ is a $C^{1+\alpha}$ local diffeomorphism, for some $\alpha > 0$, and has bounded geometry with respect to \mathcal{B} .*
- (ii) *The elements of the exchange pseudo-group E_G are C^{1+} diffeomorphisms with respect to the C^{1+} atlas \mathcal{B} .*

We observe that the elements of the exchange pseudo-group E_G are C^{1+} diffeomorphisms with respect to the C^{1+} atlas \mathcal{B} if, and only if, the map g_G is a C^{1+} local diffeomorphisms with respect to $\mathcal{B}|_{\mathbb{S}_G}$.

Lemma 3.4 *The map $G \mapsto \mathcal{S}(T_G^s, \mathcal{A}^s(T_G^s, G, \rho))$ associates to every C^{1+} conjugacy class of C^{1+} Anosov diffeomorphisms a C^{1+} self-renormalizable structure.*

Proof. By Lemma 3.2, the Markov map $m_s = m_{s,G}$ is a C^{1+} local diffeomorphism and has bounded geometry with respect to the C^{1+} atlas $\mathcal{A}^s(T_G^s, G, \rho)$. By Lemma 3.3, the elements of the exchange pseudo-group E_G are C^{1+} diffeomorphisms with respect to the C^{1+} atlas $\mathcal{A}^s(T_G^s, G, \rho)$. \square

Let h be the topological conjugacy between G and the Anosov automorphism G_γ . The map h induces a unique homeomorphism $h_T : T_G^s \rightarrow T_{G_\gamma}^s$ given by $h_T(x) = h(x)$ and a unique homeomorphism $h_{\mathbb{S}} : \mathbb{S}_G \rightarrow \mathbb{S}_{G_\gamma}$ given by $h_{\mathbb{S}}(x) = h(x)$. Furthermore,

$$h_T \circ m_{s,G} = m_{s,G_\gamma} \circ h_T \quad \text{and} \quad h_{\mathbb{S}} \circ m_{s,G} = m_{s,G_\gamma} \circ h_{\mathbb{S}}.$$

Hence, every C^{1+} self-renormalizable structure $\mathcal{S}(T_G^s, \mathcal{B})$ on T_G^s determines a unique C^{1+} self-renormalizable structure $\mathcal{S}(T_{G_\gamma}^s, (h_T)_*\mathcal{B})$ on $T_{G_\gamma}^s$ that is the pushforward structure of $\mathcal{S}(T_G^s, \mathcal{B})$ by h_T . Hence, the map $\mathcal{S}(T_G^s, \mathcal{B}) \mapsto \mathcal{S}(T_{G_\gamma}^s, (h_T)_*\mathcal{B})$ determines a one-to-one correspondence between C^{1+} self-renormalizable structures on T_G^s and C^{1+} self-renormalizable structures on $T_{G_\gamma}^s$.

3.9 Circle diffeomorphisms and self-renormalizable structures

Let $g = (g, \mathbb{S}, \mathcal{A})$ be a C^{1+} circle diffeomorphism. Let $h : \mathbb{S} \rightarrow \mathbb{S}^1$ be the conjugacy map between g and the rigid rotation g_γ . Let $\mathcal{A}_g = h_*\mathcal{A}$ be the pushforward of the atlas \mathcal{A} by h . Hence, by construction $(g, \mathbb{S}, \mathcal{A})$ is C^{1+} conjugate to $(g_\gamma, \mathbb{S}^1, \mathcal{A}_g)$. Hence, every C^{1+} conjugacy class of a circle diffeomorphism $(g, \mathbb{S}, \mathcal{A})$ contains a C^{1+} circle diffeomorphisms of the form $(g_\gamma, \mathbb{S}^1, \mathcal{A}_g)$.

Remark 3.1 *We note that $\mathbb{S}^1 = \mathbb{S}_{G_\gamma}$, $\mathbb{T}_{g_\gamma} = \mathbb{T}_{G_\gamma}^s$, $g_\gamma = g_{G_\gamma}$ and $m_{g_\gamma} = m_{G_\gamma}$.*

By the above remark, every C^{1+} circle diffeomorphism $(g_\gamma, \mathbb{S}^1, \mathcal{A})$ determines a C^{1+} atlas \mathcal{A}^T in $\mathbb{T}_{g_\gamma} = \mathbb{T}_{G_\gamma}^s$ and a corresponding C^{1+} structure $\mathcal{S}(\mathbb{T}_{G_\gamma}^s, \mathcal{A}^T)$.

Theorem 3.1 *The map $(g_\gamma, \mathbb{S}^1, \mathcal{A}) \mapsto \mathcal{S}(\mathbb{T}_{G_\gamma}^s, \mathcal{A}^T)$ induces a one-to-one correspondence between C^{1+} circle diffeomorphisms that are C^{1+} fixed points of renormalization and C^{1+} self-renormalizable structures.*

Proof. Given a C^{1+} circle diffeomorphism $(g_\gamma, \mathbb{S}^1, \mathcal{A})$, by Section 2.4, this determines a circle train-track $\mathbb{T}_{g_\gamma} = \mathbb{T}_{G_\gamma}^s$ and an atlas \mathcal{A}^T on $\mathbb{T}_{G_\gamma}^s$. Since, $(g_\gamma, \mathbb{S}^1, \mathcal{A})$ is a C^{1+} fixed point of renormalization then by Lemma 2.2 the Markov map $m_{g_\gamma} = m_{G_\gamma}$ is a C^{1+} local diffeomorphism with respect to \mathcal{A}^T . Conversely, if $\mathcal{S}(\mathbb{T}_{g_\gamma})$ is a C^{1+} self-renormalizable structure, then $m_{g_\gamma} = m_{G_\gamma}$ is a local $C^{1+\alpha}$ diffeomorphism with respect to a $C^{1+\alpha}$ atlas \mathcal{A}^T of $\mathcal{S}(\mathbb{T}_{g_\gamma})$. Hence, by Lemma 2.2, g_γ is a C^{1+} circle diffeomorphism that is a C^{1+} fixed point of renormalization with respect to the atlas $\mathcal{A}^T|_{\mathbb{S}^1}$. \square

Chapter 4

HR Structures

A C^{1+} conjugacy class of Anosov diffeomorphisms of the torus is determined by its *HR-structure*, where HR stands for Hölder ratios. These associate an affine structure to each stable and unstable leaf in such a way that these vary Hölder continuously with the leaf (see Pinto and Rand [31]).

An affine structure on a leaf is equivalent to a *ratio function* $r(x, y, z)$ which can be thought of as prescribing the ratio of the size of the segment between y and z to that between x and y for all points x, y and z in the leaf. We can restrict the domain of r to those triples such that $x \prec y \prec z$. A ratio function is positive, continuous in x, y and z and satisfies the following equalities:

$$r(x, y, z) = r(z, y, x)^{-1} \text{ and } r(w, x, z) = r(w, x, y)(1 + r(x, y, z)). \quad (4.1)$$

For $\iota = s$ and u , let T^ι be the set of all triples (x, y, z) which are contained in some extended ι -leaf segment and are such that $x \prec y \prec z$.

Let d_ι be the metric on T_G^ι defined as follows: if $\xi, \eta \in T_G^\iota$, $d_\iota(\xi, \eta) = 2^{-n}$ if, for $0 \leq i < n$, $G_\iota^i \xi$ and $G_\iota^i \eta$ are both in A or both in B while for $i = n$ this is not true.

We say that $r^\iota : T^\iota \rightarrow \mathbb{R}^+$ is a ι -*ratio function* if (i) r^ι is continuous in T^ι ; (ii) r^ι is invariant under the Anosov map G , i.e. $r^\iota(x, y, z) = r^\iota(Gx, Gy, Gz)$ for all $(x, y, z) \in T^\iota$ and (iii) for every basic ι -holonomy maps θ between the leaves ξ and η ,

$$\left| \log \frac{r^\iota(\theta x, \theta y, \theta z)}{r^\iota(x, y, z)} \right| \leq c_0 d_{\iota'}(\xi, \eta)^\alpha \quad (4.2)$$

where the constants $\alpha \in (0, 1)$ and $c_0 \in \mathbb{R}^+$ only depend upon r and not on the points (x, y, z) and $(\theta x, \theta y, \theta z)$ or on ξ and η . Inequality (4.2) and the invariance of r^ι under

the Anosov map implies

$$\left| \log \frac{r^\iota(\theta x, \theta y, \theta z)}{r^\iota(x, y, z)} \right| \leq c_1 (d_{\iota'}(\xi, \eta) d_\iota(x, z))^\alpha \quad (4.3)$$

where $d_\iota(x, z)$ is the d_ι distance between the leaf segments in T_G^ι containing x and z and the constants $\alpha \in (0, 1)$ and $c_0 \in \mathbb{R}^+$ only depend upon r and not on the points (x, y, z) and $(\theta x, \theta y, \theta z)$ or on ξ and η . By Proposition 3.4 of [31] this implies that r^ι is Hölder continuous along leaves. We call $r^s : T^s \rightarrow \mathbb{R}^+$ a *stable ratio function* and $r^u : T^u \rightarrow \mathbb{R}^+$ an *unstable ratio function*.

Definition 4.1 *A HR-structure is a pair (r^s, r^u) consisting of a stable and an unstable ratio function.*

4.1 Basic holonomies and the atlas associated to a ratio function

We will use the notion of a *bounded atlas* on T_G^ι . This is a set of charts of a $C^{1+\alpha}$ structure on T_G^ι with the following two properties: (i) the charts are $C^{1+\alpha}$ -compatible for some $\alpha \in (0, 1)$ and their overlap maps are uniformly bounded in the $C^{1+\alpha}$ norm and (ii) m_ι has bounded geometry in these charts. Any $C^{1+\alpha}$ structure with bounded geometry contains a bounded atlas by compactness of T_G^ι .

We now define the bounded atlas \mathcal{A}_{r^ι} . This is a set of charts of a $C^{1+\alpha}$ structure on T_G^ι which is determined by a ι -ratio function r^ι . Suppose that J is a segment in T_G^ι with endpoints x and z with $x \prec z$. If ℓ is any extended ι -leaf segment, let $\lambda_\ell : J \rightarrow \ell$ be a continuous map such that $\lambda_\ell(y)$ is an intersection of the ι' -leaf segment y with ℓ . Since ℓ is an extended leaf segment, there might be two choices for λ_ℓ . A ratio function r on ℓ determines a unique homeomorphism $j_\ell : \ell \rightarrow [0, 1]$ which preserves the affine structure of ℓ determined by r and a mapping $i_{r, J, \ell} : J \rightarrow \mathbb{R}$ defined by $i_{r, J, \ell}(z) = j_\ell \circ \lambda_\ell(y)$.

Now if r^ι is any ι -ratio function, the atlas \mathcal{A}_{r^ι} consists of all charts of the form $i_{r, J, \ell}$. By Proposition 4.1 below all these charts are $C^{1+\alpha}$ compatible for some $\alpha \in (0, 1)$ and the atlas is bounded.

Proposition 4.1 *Suppose that r is a ι -ratio function. Then there is $\alpha \in (0, 1)$ such that all basic ι -holonomies $\theta : \ell \rightarrow \ell'$ are $C^{1+\alpha}$ diffeomorphisms for some $\alpha \in (0, 1)$*

as mappings between the af on ℓ and ℓ' defined by r . Moreover, the $C^{1+\alpha}$ norm of the induced maps $\tilde{\theta}$ is uniformly bounded in \mathcal{A}_r .

Note that when we say that the $C^{1+\alpha}$ norm of the mappings θ is uniformly bounded in \mathcal{A}_r we mean that where defined the maps $j^{-1} \circ \tilde{\theta} \circ i$ are uniformly bounded in the $C^{1+\alpha}$ norm for all charts i and j contained in \mathcal{A}_r .

Proof. We must check that $j^{-1} \circ \tilde{\theta} \circ i$ is $C^{1+\alpha}$ for some $\alpha > 0$. Take a sequence $x_n \in \ell$ converging to x . Let I_n be the image by i of the segment in ℓ between x_n and x and let $J_n = j \circ \theta \circ i^{-1}(I_n)$. By inequality (4.3),

$$\frac{|J_{n+1}|}{|I_{n+1}|} \in (1 \pm \mathcal{O}(|I_n|^\beta)) \frac{|J_n|}{|I_n|} \quad (4.4)$$

for some $0 < \beta < 1$ which only depends upon r . Thus $|J_n|/|I_n|$ converges to a limit as $n \rightarrow \infty$ which is $\theta'(x)$. The convergence is exponentially fast i.e. $\theta'(x)|I_n|/|J_n| \in 1 \pm \mathcal{O}(|I_n|^\beta)$ whence θ' is Hölder continuous with exponent α for all $0 < \alpha < \beta$. The uniform boundedness in \mathcal{A}_r follows because the bound in inequality (4.4) just depends upon r . \square

4.2 Realized HR structures

Let G be a C^{1+} Anosov diffeomorphism in \mathcal{G} , and let $\mathcal{L}^u(G, \rho)$ be an unstable lamination atlas associated to a Riemannian metric ρ . If I is an unstable leaf segment then by $|I|$, we mean the length of the unstable leaf containing I measured using the Riemannian metric ρ . Let $h_G : \mathbb{T} \rightarrow \mathbb{T}$ be the topological conjugacy between the automorphism G_γ and the Anosov diffeomorphism G . Using the mean value theorem and the fact that G is $C^{1+\alpha}$ uniformly hyperbolic, for some $\alpha > 0$, for all short unstable leaf segments K of G_γ and all leaf segments I and J contained in K , the unstable realized ratio function r_G^u given by

$$r_G^u(I : J) = \lim_{n \rightarrow \infty} \frac{|G^{-n}(h_G(J))|}{|G^{-n}(h_G(I))|} \quad (4.5)$$

is well-defined (see Lemma 3.6 in [31]). Similarly, we have the definition of stable realized ratio function r_G^s .

Theorem 4.1 *The map $G \rightarrow (r_G^s, r_G^u)$ determines a one-to-one correspondence between C^{1+} conjugacy classes of Anosov diffeomorphisms G and pairs of stable and unstable ratio functions.*

See proof of Theorem 4.1 in [31].

4.3 Self-renormalizable structures and ratio functions

Theorem 4.2 *The map $\mathcal{S} \mapsto r_{\mathcal{S}}^{\iota}$ induces a one-to-one correspondence between C^{1+} self-renormalizable structures \mathcal{S} on T_G^{ι} and ι -ratio functions r^{ι} .*

See also Pinto, Rand and Ferreira [34–36].

Proof. Let \mathcal{S} be a C^{1+} self-renormalizable structure on T_G^{ι} and let \mathcal{A} be a bounded atlas for \mathcal{S} . Let $(x_0, x_1, x_2) \in T^{\iota}$. Let $x_k^n = (G_{\iota})^{-n}x_k$ and suppose they are not contained in the ι -boundary of A or B . Let $z_k^n = \pi_{\iota}x_k^n$. Then $m_{\iota}^n(z_k^n) = z_k^0$. Consequently, the points z_0^n, z_1^n and z_2^n are at most a distance apart which is $\mathcal{O}(\nu^n)$ for some $\nu \in (0, 1)$. Thus if (i, U) is a chart in \mathcal{A} such that U contains z_0^n, z_1^n and z_2^n and we define

$$r_n(z_0^n, z_1^n, z_2^n) = \frac{|i(z_2^n) - i(z_1^n)|}{|i(z_1^n) - i(z_0^n)|}$$

then $r_n(z_0^n, z_1^n, z_2^n)$ is independent of the chart in \mathcal{A} up to multiplication by an error term that is $1 \pm \mathcal{O}(\nu^{\beta n})$ for some $\beta > 0$. But m_{ι} is smooth in the atlas \mathcal{A} and therefore

$$r(x_0, x_1, x_2) = \lim_{n \rightarrow \infty} r_n(z_0^n, z_1^n, z_2^n)$$

exists and is approached exponentially fast i.e.

$$r(x_0, x_1, x_2) \in (1 \pm \mathcal{O}(\kappa^n))r_n(z_0^n, z_1^n, z_2^n)$$

for some $\kappa \in (0, 1)$. If for some $n > N$, x_k^n is contained in the ι -boundary of A or B then we have two choices z_k^n and $h(z_k^n)$ for the points $\pi_{\iota}(x_k^n)$, but since h is smooth the ratios $r_n(z_0^n, z_1^n, z_2^n)$ and $r_n(hz_0^n, hz_1^n, hz_2^n)$ converge to the same limit. Thus r is well-defined and it is Hölder continuous in (x_0, x_1, x_2) with respect to the metric d_{ι} .

Now we must check that r depends Hölder continuously on the leaf. Suppose that $(x_0, x_1, x_2) \in T^{\iota}$ lie in the leaf $\xi \in T_G^{\iota}$ and

$$(x'_0, x'_1, x'_2) = (\theta x_0, \theta x_1, \theta x_2)$$

is the image under the basic holonomy θ from ξ to $\eta \in T_G^{\iota}$. Assume that ξ and η are in a common n -cylinder of T_G^{ι} . Then, for all $0 < i < n$, $x_k^i = (G_{\iota})^{-i}x_k$ and $x_k^{i'} = (G_{\iota})^{-i}x_k'$

are either both in A or both in B . Therefore, if $z_k^i = \pi_\iota x_k^i$ and $z_k^{i'} = \pi_\iota x_k^{i'}$, $z_k^i = z_k^{i'}$ for $0 < i < n$. Consequently,

$$r(x_0, x_1, x_2), \quad r(\theta x_0, \theta x_1, \theta x_2) \in (1 \pm \mathcal{O}(\kappa^n))r_n(z_0^n, z_1^n, z_2^n)$$

for some $0 < \kappa < 1$ independent of the triples and leaf segments ξ and η . It follows that

$$\left| \log \frac{r(\theta x_0, \theta x_1, \theta x_2)}{r(x_0, x_1, x_2)} \right| \leq \mathcal{O}(\kappa^n)$$

as required. A similar argument applies if x_0 , x_1 and x_2 are not contained in a single leaf segment but are all contained in an extended leaf segment.

The converse follows from Proposition 4.1. For \mathcal{S} we take the structure determined by the atlas \mathcal{A}_r defined above. \square

Chapter 5

Solenoid functions

Let \mathbf{sol}^u denote the set of all ordered pairs (I, J) of unstable spanning leaf segments of the Markov rectangles A and B of G_γ such that the intersection of I and J consists of a single endpoint. Since the set \mathbf{sol}^u is topologically a finite disjoint union of disjoint intervals, i.e. the disjoint union of a primary stable leaf of A and a primary stable leaf of B , it has a natural topological structure (see Pinto and Rand [28]).

We define a pseudo-metric $d_{\mathbf{sol}^u} : \mathbf{sol}^u \times \mathbf{sol}^u \rightarrow \mathbb{R}^+$ on the set \mathbf{sol}^u by

$$d_{\mathbf{sol}^u}((I, J), (I', J')) = \max \{d(I, I'), d(J, J')\}.$$

Similarly, we define the \mathbf{sol}^s and the pseudo-metric $d_{\mathbf{sol}^s} : \mathbf{sol}^s \times \mathbf{sol}^s \rightarrow \mathbb{R}^+$.

Let G be a C^{1+} Anosov diffeomorphism in \mathcal{G} . We call the restriction $r_G^u|_{\mathbf{sol}^u}$ of an unstable ratio function r_G^u to \mathbf{sol}^u , the *unstable realized solenoid function* and we denote it by $\sigma_G = r_G^u|_{\mathbf{sol}^u}$. Similarly, we call the restriction $r_G^s|_{\mathbf{sol}^s}$ of an unstable ratio function r_G^s to \mathbf{sol}^s , the *stable realized solenoid function* and we denote it by $\sigma_G = r_G^s|_{\mathbf{sol}^s}$. By construction, the restriction σ_G of the unstable ratio function to \mathbf{sol}^u gives a Hölder continuous function satisfying the matching condition and the boundary condition, as we now proceed to describe (see Theorem 6.1 in [31]).

5.1 Hölder continuity of solenoid functions

The *Hölder continuity* of solenoid functions means that for all $t = (I, J)$ and $t' = (I', J')$ in $\mathbf{sol} = \mathbf{sol}^u$,

$$|\sigma_G(t) - \sigma_G(t')| \leq \mathcal{O}((d_{\mathbf{sol}}(t, t'))^\alpha),$$

for some $\alpha > 0$.

5.2 Matching condition

Let $(I, J) \in \mathbf{sol}$. Suppose that there are pairs

$$(I_0, I_1), (I_1, I_2), \dots, (I_{n-2}, I_{n-1}) \in \mathbf{sol}$$

such that $G_\gamma I = \bigcup_{j=0}^{k-1} I_j$ and $G_\gamma J = \bigcup_{j=k}^{n-1} I_j$. Then

$$\frac{|G_\gamma J|}{|G_\gamma I|} = \frac{\sum_{j=k}^{n-1} |I_j|}{\sum_{j=0}^{k-1} |I_j|} = \frac{\sum_{j=k}^{n-1} \prod_{i=1}^j |I_i|/|I_{i-1}|}{1 + \sum_{j=1}^{k-1} \prod_{i=1}^j |I_i|/|I_{i-1}|}.$$

Hence, the realized solenoid function σ_G must satisfy the *matching condition* (see Figure 5.1) for all such leaf segments:

$$\sigma_G(I : J) = \frac{\sum_{j=k}^{n-1} \prod_{i=1}^j \sigma_G(I_{i-1} : I_i)}{1 + \sum_{j=1}^{k-1} \prod_{i=1}^j \sigma_G(I_{i-1} : I_i)}. \quad (5.1)$$

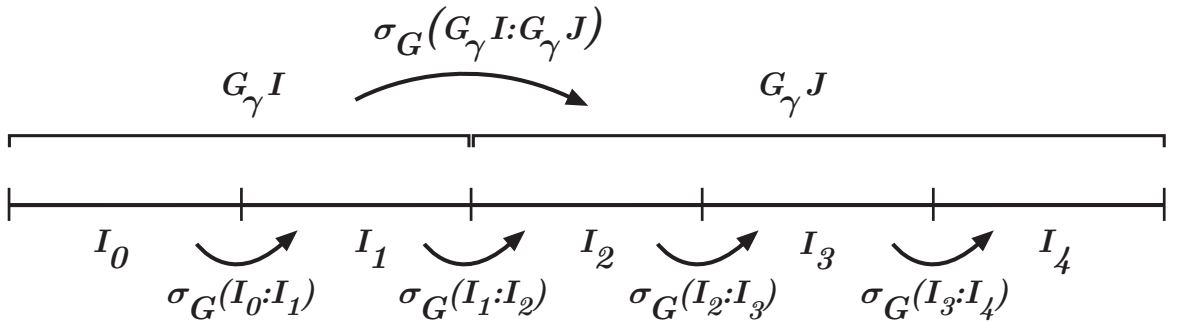

Figure 5.1: The matching condition for the solenoid function σ_G with $k = 2$ and $n = 5$.

Lemma 5.1 *Let $\sigma_G : \mathbf{sol} \rightarrow \mathbb{R}^+$ be a realized solenoid function. For $a \in \mathbb{N}$, the matching condition holds for σ_G if, for every $(K_1, K_2) \in \mathbf{sol}$, the following conditions hold:*

(i) *if $K_1, K_2 \in A$, then*

$$\sigma_G(K_1 : K_2) = \prod_{k=1}^{a+1} \sigma_G(I_k : I_{k+1}) \left(\frac{1 + \sum_{j=a+2}^{2a+1} \prod_{k=a+2}^j \sigma_G(I_k : I_{k+1})}{1 + \sum_{j=1}^a \prod_{k=1}^j \sigma_G(I_k : I_{k+1})} \right). \quad (5.2)$$

where I_1, \dots, I_{2a+2} are such that $G_\gamma(K_1) = \cup_{i=1}^{a+1} I_i$, $G_\gamma(K_2) = \cup_{i=a+2}^{2a+2} I_i$ and $(I_i, I_{i+1}) \in \mathbf{sol}$ for $i \in \{1, \dots, 2a+1\}$.

(ii) *if $K_1 \in A$ and $K_2 \in B$, then*

$$\sigma_G(K_1 : K_2) = \prod_{k=1}^{a+1} \sigma_G(I_k : I_{k+1}) \left(1 + \sum_{j=1}^a \prod_{k=1}^j \sigma_G(I_k : I_{k+1}) \right)^{-1} \quad (5.3)$$

where I_1, \dots, I_{a+2} are such that $G_\gamma(K_1) = \cup_{i=1}^{a+1} I_i$, $G_\gamma(K_2) = I_{a+2}$ and $(I_i, I_{i+1}) \in \mathbf{sol}$ for $i \in \{1, \dots, a+1\}$.

(iii) *if $K_1 \in B$ and $K_2 \in A$, then*

$$\sigma_G(K_1 : K_2) = \sigma_G(I_1 : I_2) \left(1 + \sum_{j=2}^{a+1} \prod_{k=2}^j \sigma_G(I_k : I_{k+1}) \right) \quad (5.4)$$

where I_1, \dots, I_{a+2} are such that $G_\gamma(K_1) = I_1$, $G_\gamma(K_2) = \cup_{i=2}^{a+2} I_i$ and $(I_i, I_{i+1}) \in \mathbf{sol}$ for $i \in \{1, a+1\}$.

Proof. If $(K_1, K_2) \in \mathbf{sol}$ then (K_1, K_2) satisfies either condition (i), (ii) or (iii) above (see Figure 7.3). Let us check that the formulas (5.2), (5.3) and (5.4) correspond to the matching condition (5.1) for σ_G .

(i) If $K_1, K_2 \in A$ then there exists $(I_i, I_{i+1}) \in \mathbf{sol}$, for $i = 1, \dots, 2a+2$, such that $G_\gamma(K_1) = I_1 \cup \dots \cup I_{a+1}$ and $G_\gamma(K_2) = I_{a+2} \cup \dots \cup I_{2a+2}$. Furthermore,

$$\frac{|G_\gamma(K_2)|}{|G_\gamma(K_1)|} = \frac{\sum_{i=a+2}^{2a+1} |I_i|}{\sum_{i=1}^{a+1} |I_i|} = \prod_{k=1}^{a+1} \frac{|I_{k+1}|}{|I_k|} \left(\frac{1 + \sum_{j=a+2}^{2a+1} \prod_{k=a+2}^j \frac{|I_{k+1}|}{|I_k|}}{1 + \sum_{j=1}^a \prod_{k=1}^j \frac{|I_{k+1}|}{|I_k|}} \right).$$

Hence, equality (5.2) follows from equality (5.1).

- (ii) If $K_1 \in A$ and $K_2 \in B$ then there exists $(I_i, I_{i+1}) \in \mathbf{sol}$, for $i = 1, \dots, a+1$, such that $G_\gamma(K_1) = I_1 \cup \dots \cup I_{a+1}$ and $G_\gamma(K_2) = I_{a+2}$. Furthermore,

$$\frac{|G_\gamma(K_2)|}{|G_\gamma(K_1)|} = \frac{|I_{a+2}|}{\sum_{i=1}^{a+1} |I_i|} = \prod_{k=1}^{a+1} \frac{|I_{k+1}|}{|I_k|} \left(1 + \sum_{j=1}^a \prod_{k=1}^j \frac{|I_{k+1}|}{|I_k|} \right)^{-1}.$$

Hence, equality (5.3) follows from equality (5.1).

- (iii) If $K_1 \in B$ and $K_2 \in A$, then there exists $(I_i, I_{i+1}) \in \mathbf{sol}$, for $i = 1, 2$, such that $G_\gamma(K_1) = I_1$ and $G_\gamma(K_2) = I_2 \cup \dots \cup I_{a+2}$. Furthermore,

$$\frac{|G_\gamma(K_2)|}{|G_\gamma(K_1)|} = \frac{\sum_{i=2}^{a+2} |I_i|}{|I_1|} = \frac{|I_2|}{|I_1|} \left(1 + \sum_{j=2}^{a+1} \prod_{k=2}^j \frac{|I_{k+1}|}{|I_k|} \right).$$

Hence, equality (5.4) follows from equality (5.1). \square

5.3 Boundary condition

Let $(I_i, I_{i+1}), (J_j, J_{j+1}) \in \mathbf{sol}$, for each $i \in \{0, \dots, m\}$ and each $j \in \{0, \dots, n\}$ with the following properties: (i) $I_0 = J_0$, (ii) $\cup_{i=1}^m I_i = \cup_{j=1}^n J_j$ and (iii) $I_i \neq J_j$ for all $i \geq 1$ and all $j \geq 1$. Then the following two ratios are equal

$$\sum_{i=1}^m \prod_{j=1}^i \frac{|I_j|}{|I_{j-1}|} = \frac{|\cup_{i=1}^m I_i|}{|I_0|} = \frac{|\cup_{j=1}^n J_j|}{|J_0|} = \sum_{i=1}^n \prod_{j=1}^i \frac{|J_j|}{|J_{j-1}|}.$$

We observe that the unstable spanning leaf segments I_1, \dots, I_m and J_1, \dots, J_n must be boundaries of Markov rectangles. Thus, a realized solenoid function σ_G must satisfy the following *boundary condition* for all such leaf segments:

$$\sum_{i=1}^m \prod_{j=1}^i \sigma_G(I_{j-1} : I_j) = \sum_{i=1}^n \prod_{j=1}^i \sigma_G(J_{j-1} : J_j). \quad (5.5)$$

Let K_1, K_2 and K_3 be the unstable spanning leaf segments as defined in Section 7. Let K_0 be the unstable spanning leaf segment in A such that $K_0 \cap K_1 = \{y_0\}$. Let the unstable spanning leaf segment I_1 be the right boundary of the Markov rectangle B and the unstable spanning leaf segment I_2 be the right boundary of the Markov rectangle A (see Figure 5.2).

Lemma 5.2 *Let $\sigma_G : \mathbf{sol} \rightarrow \mathbb{R}^+$ be a realized solenoid function. The boundary condition holds for σ_G if the following conditions hold*

$$\sigma_G(K_0 : K_1)(1 + \sigma_G(K_1 : K_2)) = \sigma_G(K_0 : I_1)(1 + \sigma_G(I_1 : I_2)); \quad (5.6)$$

and

$$\sigma_G(K_3 : K_2)(1 + \sigma_G(K_2 : K_1)) = \sigma_G(K_3 : I_2)(1 + \sigma_G(I_2 : I_1)). \quad (5.7)$$

Proof. Since I_1 and K_2 are the unstable boundaries of the Markov rectangle B and I_2 and K_1 are the unstable boundaries of the Markov rectangle A , then the boundary condition (5.5) corresponds to

$$\frac{|K_1|}{|K_0|} \left(1 + \frac{|K_2|}{|K_1|} \right) = \frac{|K_1 \cup K_2|}{|K_0|} = \frac{|I_1 \cup I_2|}{|K_0|} = \frac{|I_1|}{|K_0|} \left(1 + \frac{|I_2|}{|I_1|} \right),$$

and

$$\frac{|K_2|}{|K_3|} \left(1 + \frac{|K_1|}{|K_2|} \right) = \frac{|K_1 \cup K_2|}{|K_3|} = \frac{|I_1 \cup I_2|}{|K_3|} = \frac{|I_2|}{|K_3|} \left(1 + \frac{|I_1|}{|I_2|} \right).$$

Hence, the boundary condition for σ_G is given by (5.6) and (5.7). \square

5.4 Solenoid functions

Definition 5.1 *A function $\sigma : \mathbf{sol} \rightarrow \mathbb{R}^+$ is a (unstable) solenoid function, if the following conditions hold: (i) σ is Hölder continuous; (ii) σ satisfies the matching condition given by the equalities (5.2), (5.3) and (5.4); and (iii) σ satisfies the boundary condition given by the equalities (5.6) and (5.7).*

By Theorem 6.1 in [31], we have the following equivalence:

Lemma 5.3 *The map $r \rightarrow r|\mathbf{sol}$ gives a one-to-one correspondence between ratio functions and solenoid functions.*

Theorem 5.1 *The map $G \rightarrow (r_G^s|\mathbf{sol}^s, r_G^u|\mathbf{sol}^u)$ determines a one-to-one correspondence between C^{1+} conjugacy classes of Anosov diffeomorphisms G and pairs of stable and unstable solenoid functions.*

See the proof of Theorem 5.1 in [31].

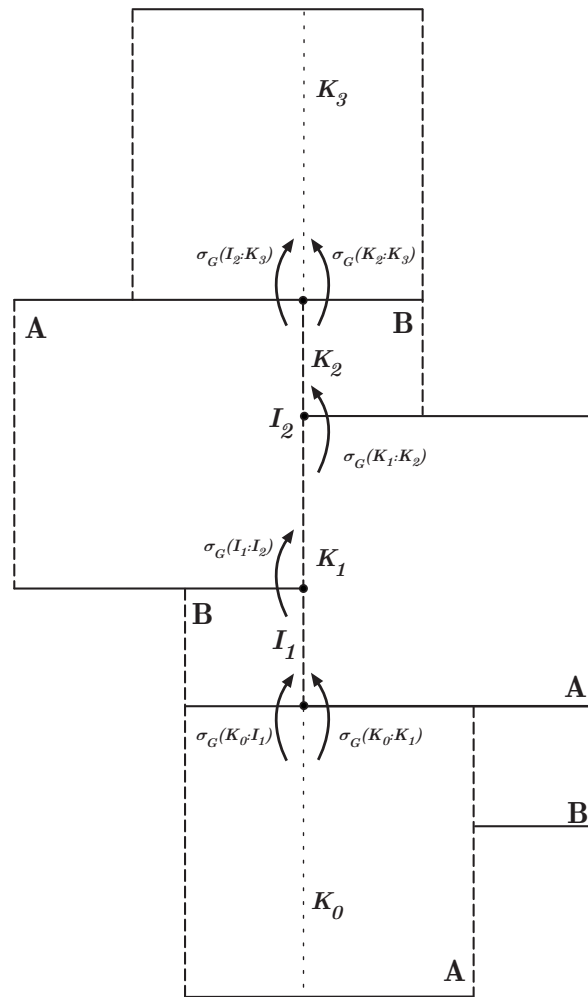

Figure 5.2: The Boundary condition for the realized solenoid function σ_G .

Chapter 6

SRB and Gibbs measures

Pinto and Rand [31] proved a one-to-one correspondence between C^{1+} conjugacy classes of Anosov diffeomorphisms on surfaces and pairs of stable and unstable ratio functions. Given an Anosov diffeomorphism, the corresponding ratio functions r^s and r^u are dual if, and only if, the Anosov diffeomorphism has an invariant measure that is absolutely continuous with respect to Lebesgue measure. In Theorem 6.4, it is proved an equivalence between C^{1+} Anosov diffeomorphisms whose SRB measure is absolutely continuous with respect to two dimensional Lebesgue measure and C^{1+} self-renormalizable structures (see Pinto, Rand and Ferreira [36]).

6.1 Duality of train-tracks

In this section we show how $T_G^{\iota'}$ can be regarded as the dual of T_G^ι where, as before, ι' denotes an element of the set $\{s, u\}$ that is not ι . The dual of T_G^ι is defined as a quotient space Σ / \sim and we will denote it by $(T_G^\iota)^*$.

Recall from Section 3.6 that a n -cylinder is a subset C of T_G^ι such that $m_\iota^n C$ is A^ι or B^ι and m_ι^n is a homeomorphism of $\text{int } C$ onto $\text{int } m_\iota^n C$. A point $\xi = (I_i)_{i=0}^\infty$ of Σ is a backward orbit of cylinders in T_G^ι i.e. I_0 is A^ι or B^ι and m_ι sends the i -cylinder I_i onto the $(i - 1)$ -cylinder I_{i-1} . There is a natural Markov map $m_{\iota,*}$ on Σ defined by $m_{\iota,*}((I_i)) = (K_i)$ where K_i is the i -cylinder containing I_{i+1} .

For $\iota \in \{s, u\}$ let j^ι denote the junction of T_G^ι . There are four special points j^1, \dots, j^4 in Σ two of which are given by the backward orbits (I_i) for which the junction $j^\iota \in I_i$

for all $i \geq 0$ while the others are given by the backward orbits (K_i) such that K_i is adjacent to I_i and contained in I'_i for all $i \geq 0$. Here I'_i is the $(i-1)$ -cylinder containing the i -cylinder I_i . These points will all be identified to give the junction j^* of $(T_G^\iota)^*$.

We define special subsets Σ_n of Σ on which we carry out identifications. A point $x = (I_i)$ is in Σ_n if one of the following two equivalent properties is true:

- (i) $m_{\iota,*}^n(x) = j^*$ but $m_{\iota,*}^{n-1}(x) \neq j^*$.
- (ii) there exists a point $y = (K_i) \in \Sigma$ such that (a) $K_{n-1} = I_{n-1}$ and (b) either $\text{int } h(I_m) \subset \text{int } K_m \neq \emptyset$ or $\text{int } I_m \subset \text{int } h(K_m) \neq \emptyset$ for all $m \geq n$. In this case we denote y by $y(x)$ or x by $x(y)$ respectively.

Note that the points j^1, \dots, j^4 are the only points in Σ_0 and we can choose their order such that $y(j^2) = j^1$, $y(j^3) = j^2$ and $y(j^4) = j^1$.

Definition 6.1 *The dual train-track $(T_G^\iota)^*$ is the quotient space of Σ in which the four points in the junction are identified and each of the pairs $x, y(x) \in \Sigma_n$ is identified in a single point.*

We call $y : \cup_{n \geq 0} \Sigma_n \rightarrow \cup_{n \geq 0} \Sigma_n$ the *identification map*. It gives a local order on the n -cylinders of Σ by saying that the cylinder containing $y(x)$ follows the cylinder containing x . This in turn induces a local order on the train-track $(T_G^\iota)^*$.

The map $m_{\iota,*} : \Sigma \rightarrow \Sigma$ induces a Markov map of $(T_G^\iota)^*$ which we also denote by $m_{\iota,*}$.

We also define a map $h_{\iota,*} : (T_G^\iota)^* \rightarrow (T_G^\iota)^*$ as follows. If $\xi_1 = (I_i)$ and $\xi_2 = (J_i)$ are in $(T_G^\iota)^*$ such that for all i , I_i and J_i meet in an endpoint and $I_i \prec J_i$, then we write $\xi_2 = h_{\iota,*}(\xi_1)$. The map $h_{\iota,*}$ is one-to-one except at the junction where it is one-to-two.

For a n -cylinder C in T_G^ι define C^* and C^\dagger by

$$C^* = \{\xi = (I_i) : I_n = K\} \quad \text{and} \quad C^\dagger = \pi_{\iota'} \circ G_\iota^n \circ \pi_\iota^{-1}(C).$$

The subsets C^* are the n -cylinders of $(T_G^\iota)^*$ and C^* and C^\dagger are called the *duals* of C (see Figure 6.1).

Note that a backward orbit (C_i^*) of cylinders of $(T_G^\iota)^*$ under $m_{\iota,*}$ corresponds to a nested sequence of cylinders C_i in T_G^ι and therefore $(C^*)^*$ is naturally identified with C .

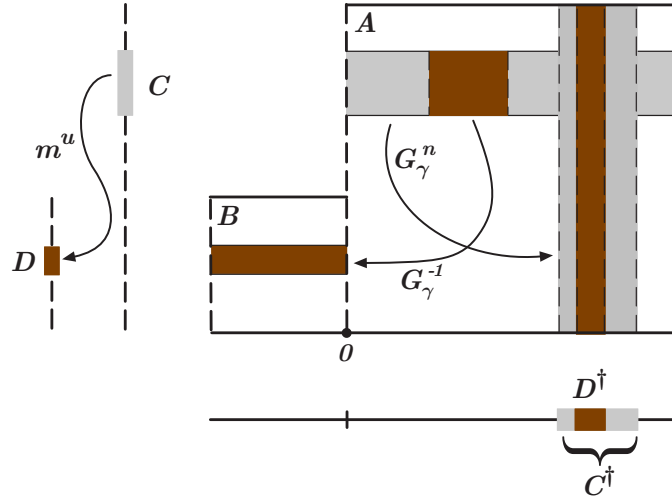

Figure 6.1: The geometric relation between a cylinder C in T_G^ι and its dual. This is obtained by taking the ι' -leaf segments in C and applying a power of G_γ to get a rectangle that is the union of ι -leaf segments. Note how a nested sequence of cylinders corresponds to a backward orbit of cylinders in the original train-track.

Lemma 6.1 *There is a natural identification of $(T_G^\iota)^*$ with $T_G^{\iota'}$ which identifies $m_{\iota,*}$ with $m_{\iota'}$, $h_{\iota,*}$ with $h_{\iota'}$ and C^* with C^\dagger for all cylinders C .*

Proof. If $\xi \in (T_G^\iota)^*$, then ξ corresponds to a point $(I_i)_{i=0}^\infty$ of Σ . But then $I_i^\dagger \subset I_{i-1}^\dagger$ and therefore this defines a point $x = x(\xi)$ of $T_G^{\iota'}$ by $x = \bigcap_{i \geq 0} I_i^\dagger$. By construction of the identification map, we have that $x : (T_G^\iota)^* \rightarrow T_G^{\iota'}$ is a homeomorphism. \square

Note that any such holonomy map induces a map $\tilde{\theta} : U \subset T_G^\iota \rightarrow T_G^\iota$ defined by $\tilde{\theta}(\pi_\iota p) = \pi_\iota \theta(p)$. This map $\tilde{\theta}$ is the identity if ℓ and ℓ' are both contained in one of the rectangles A or B . If one is contained in rectangle A and other in rectangle B then $\tilde{\theta}$ is the map h .

6.2 The SRB measures and their ratio decomposition

Suppose that \mathcal{S} is a C^{1+} self-renormalizable structure on T_G^ι . Let \mathcal{A} be a bounded atlas for it. Fix a point $\xi \in \Sigma$. Then $\xi = (I_i)_{i=0}^\infty$ corresponds to a backward orbit of cylinders in T_G^ι . Each I_i is an i -cylinder. For $i \geq 1$ let I_i' be the $(i-1)$ -cylinder

containing I_i . Let the *scaling function* σ be defined by

$$\sigma(\xi) = \lim_{i \rightarrow \infty} \frac{|I_i|}{|I'_i|} \quad (6.1)$$

where for large i the ratios $|I_i|/|I'_i|$ are measured in a chart of the atlas \mathcal{A} containing I'_i . Because the atlas is bounded, as $i \rightarrow \infty$ the ratio becomes independent of the chart up to a multiplicative error of the form $1 \pm \mathcal{O}(|I'_i|^\alpha)$ which is exponentially close to one. Thus, since m_i is a local diffeomorphism with bounded geometry in \mathcal{S} , the approach to the limit is exponentially fast in i . Moreover, if ξ and η are in a common n -cylinder then $\sigma(\xi)/\sigma(\eta) \in 1 \pm \mathcal{O}(\kappa^n)$ for some $0 < \kappa < 1$ independent of the leaf segments ξ and η . Thus σ is Hölder continuous in the metric $d_{i'}$. Finally, note that σ does not depend upon the atlas chosen because the charts are C^{1+} compatible.

The duality between the identification map in $(T_G^\nu)^*$ and the holonomy in T_G^ν implies that $\sigma : (T_G^\nu)^* \cong T_G^{\nu'} \rightarrow \mathbb{R}^+$ is a continuous map, except at the junction where it is multi-valued.

Let μ^* be the Gibbs state on $T_G^{\nu'}$ whose potential is σ . That is, μ^* is the unique $m_{i'}$ -invariant probability measure on $T_G^{\nu'}$ such that for all n -cylinders

$$\mu^*(C) \in [d^{-1}, d] \exp(S_n \sigma(C)) \quad (6.2)$$

where $d > 1$ is a constant which is independent of C and n and

$$S_n \sigma(C) = \max_{\xi \in C} (\sigma(\xi) + \cdots + \sigma(m_{i'}^{n-1} \xi)).$$

Let $\mu = \mu_{\mathcal{S}}$ be the probability measure on T_G^ν such that $\mu(C) = \mu^*(C^*)$ for all cylinders C . Note that μ is a measure because μ^* is invariant and μ is invariant because μ^* is a measure.

Proposition 6.1 *A C^{1+} self-renormalizable structure \mathcal{S} on T_G^ν determines a unique measure $\mu = \mu_{\mathcal{S}}$ which is m_i -invariant and absolutely continuous with respect to the lengths determined by any bounded atlas of \mathcal{S} . In particular, for this measure and such an atlas the ratios $\mu(C)/|C|$ are uniformly bounded away from 0 and ∞ for all cylinders C in T_G^ν where the length $|C|$ is measured in any chart of the atlas which contains C .*

Proof. From inequality (6.2) and the Hölder continuity of σ , the ratios $\mu(C)/|C| = \mu(C^*)/|C|$ are uniformly bounded away from zero and infinity. μ is m_i -invariant

because μ^* is a measure. It is unique because there is at most one invariant measure which is absolutely continuous with respect to Lebesgue measure. \square

We will call $\mu = \mu_{\mathcal{S}}^t$ the *SRB measure* of T_G^t for the self-renormalizable structure \mathcal{S} . It has the following important property: for every Borel subset A in T_G^t ,

$$\lim_{n \rightarrow \infty} \lambda(m_t^{-n} A) = \mu(A)$$

for every probability measure λ equivalent to Lebesgue measure (e.g. Theorem 1.2 of [17]). This implies that if \mathcal{A} is a bounded atlas for \mathcal{S} and E is any interval in T_G^t , then

$$\mu(E) = \lim_{n \rightarrow \infty} \sum_C |E_C| \quad (6.3)$$

where the sum is over all n -cylinders C , $E_C = C \cap m_t^{-n} E$ and $|E_C|$ is measured in any chart of \mathcal{A} containing E_C .

Lemma 6.2 *Let I , J and K be three intervals in A^t or B^t with K containing both I and J . Then*

$$\frac{\mu(I)}{\mu(J)} \in (1 + \mathcal{O}(|K|^\alpha)) \frac{|I|}{|J|} \quad (6.4)$$

for some $0 < \alpha \leq 1$ independent of I , J and K . Here $|I|$, $|J|$ and $|K|$ are measured in any bounded atlas of \mathcal{S} . Consequently, the inverse of the potential σ is the Jacobian of the Gibbs state μ^* i.e. $1/\sigma$ is the Radon-Nikodym derivative $d(\mu^* \circ m_{t,*})/d\mu^*(\xi)$.

Proof. By equation (6.3),

$$\frac{\mu(I)}{\mu(K)} = \lim_{n \rightarrow \infty} \frac{\sum |I_C|}{\sum |K_C|}$$

where the sums are over the same ranges as in equation (6.3). However, since I_C and K_C are preimages of m_t^n and m_t has Hölder continuous derivative in a bounded atlas of \mathcal{S} ,

$$\frac{|I_C|}{|K_C|} \in (1 \pm \mathcal{O}(|K|^\alpha)) \frac{|I|}{|K|}$$

for some $0 < \alpha \leq 1$ independent of I and K . Thus,

$$\frac{\mu(I)}{\mu(K)} \in (1 \pm \mathcal{O}(|K|^\alpha)) \frac{|I|}{|K|}.$$

This proves equation (6.4).

Now let ξ , I_i and I'_i be as in the definition (6.1) of σ . Then, by (6.4), we have

$$\mu(I_i)/\mu(I'_i) \in (1 \pm (|I_i|^\alpha))\sigma(\xi).$$

Taking the limit

$$\begin{aligned}
\sigma^{-1}(\xi) &= \lim_{i \rightarrow \infty} \frac{\mu(I'_i)}{\mu(I_i)} = \lim_{i \rightarrow \infty} \frac{\mu^*(I'_{i,*})}{\mu(I_i^*)} \\
&= \lim_{i \rightarrow \infty} \frac{\mu^*(m_{\iota,*}(I_i^*))}{\mu^*(I_i^*)} \\
&= \frac{d(\mu^* \circ m_{\iota,*})}{d\mu^*}(\xi).
\end{aligned}$$

In this we are using the fact that, since I'_i is the $(i-1)$ -cylinder containing the i -cylinder I_i , $m_{\iota,*}(I_i^*) = I'_{i,*}$. \square

Suppose that we are given a ι -ratio function r . This determines an affine structure on the ι -leaves ℓ . For any two segments I and J in a common ι -leaf ℓ , we define $r(I : J)$ as the ratio between I and J determined by the affine structure on ℓ . If I_j is any family of intervals in a ι -leaf which are disjoint on their interiors then we define $r(\cup_j I_j : J)$ to be $\sum_j r(I_j : J)$.

Lemma 6.3 *For all open subsets C of T_G^ι*

$$\mu(C) = \int r_\xi^\iota(C) \mu^*(d\xi)$$

where $r_\xi^\iota(C) = r^\iota(\pi_\iota^{-1}C \cap \xi : \xi)$, the integral is over all leaf segments $\xi \in T_G^\iota$ and $r_\xi^\iota(C) = 0$ if $\xi \cap \pi_\iota^{-1}C = \emptyset$.

Proof. If $I \subset T_G^\iota$ is an interval and C is a n cylinder then, as above, let I_C be the connected component of $m_\iota^{-n}(I)$ which is contained in C . Then

$$\begin{aligned}
\mu(I) &= \lim_{n \rightarrow \infty} \sum \mu(I_C) \\
&= \lim_{n \rightarrow \infty} \sum (1 \pm \mathcal{O}(\nu^n)) \frac{|I_C|}{|C|} \mu(C) \\
&= \lim_{n \rightarrow \infty} (1 \pm \mathcal{O}(\nu^n)) \sum r_{\xi_C}(I) \mu^*(C^*) \\
&= \int r_\xi(I) \mu^*(d\xi)
\end{aligned}$$

for all choices of $\xi_C \in C^*$. In this, all sums are over the set of all n -cylinders C and $\mu(I_C)/\mu(C) = (1 \pm \mathcal{O}(\nu^n))|I_C|/|C|$ by Lemma 6.2. \square

Lemma 6.4 *The ratios $\mu(C)/r_\xi^\iota(C)$ where C is a cylinder in T_G^ι and $\xi \in T_G^\iota$ is such that $\xi \cap \pi_\iota^{-1}C \neq \emptyset$ are uniformly bounded away from 0 and ∞ .*

Proof. By Lemma 6.3

$$\frac{\mu(C)}{r_\xi^\iota(C)} = \int \frac{r_\eta^\iota(C)}{r_\xi^\iota(C)} \mu^*(d\eta).$$

But $r_\eta^\iota(C)/r_\xi^\iota(C)$ is uniformly bounded away from 0 and ∞ by the Hölder continuous dependence of the ratio function upon the leaf segment. \square

Now we construct a 2-dimensional measure ρ_S^ι . If C is a cylinder in T_G^ι let $C^e = \pi_\iota^{-1}C$ be the union of all the leaf segments in C . We define $\rho_S^\iota(C^e)$ to be $\mu(C)$. We call R a cylinder of G if for some n , $G^{-n}R$ is of the form C^e for some cylinder C in T_G^ι . We define

$$\rho_S^\iota(R) = \rho_S^\iota(C^e) = \mu(C).$$

This defines a G -invariant probability measure on \mathbb{T} .

We will see later that ρ_S^ι is the SRB measure of the C^{1+} conjugacy class of G_ι giving rise to the self-renormalizable structure on T_G^ι .

Suppose that Q is any open subset of \mathbb{T} . Let $r_\xi^\iota(Q)$ denote the ratio $r^\iota(Q \cap \xi : \xi)$ where we adopt the convention that $r_\xi^\iota(Q) = 0$ if $\xi \cap Q = \emptyset$.

For simplicity, assume that $Q \subset \mathbb{T}$ is a small connected set. Hence, there is an open connected set $D \subset T_G^{\iota'}$ with the following properties: (i) for every $\xi \in D$ there is a unique extended leaf ξ' extending ξ so that $\xi' \cap Q$ is connected and (ii) $Q = \cup_{\xi \in D} (\xi' \cap Q)$.

Theorem 6.1 (*Ratio decomposition of 2-dimensional SRB measures*)

$$\rho_S^\iota(Q) = \int_{\xi \in D} r_\xi^\iota(Q) \mu^*(d\xi).$$

Proof. It is sufficient to prove this for the case where Q is a cylinder of G i.e. where for some n , $G^{-n}Q$ is of the form $C^e = \pi_\iota^{-1}C^\iota$ for some cylinder C^ι in T_G^ι .

Let $C^{\iota'}$ denote the projection $\pi_{\iota'}Q$ of Q into $T_G^{\iota'}$. Then $C^{\iota'}$ is a n cylinder of $T_G^{\iota'}$. Let $C_j^{\iota',k}$ denote the $(n+k)$ -cylinders of $T_G^{\iota'}$ contained in $C^{\iota'}$. Let $Q_j^k = Q \cap (\pi_{\iota'}^{-1}C_j^{\iota',k})$ so that $Q = \cup_j Q_j^k$.

We first note that

$$\rho(Q_j^k) = (1 \pm \mathcal{O}(\nu^{n+k})) r_\xi(Q) \mu^*(C_j^{\iota',k}) \quad (6.5)$$

for all $\xi \in C_j^{\iota',k}$ where $\nu \in (0, 1)$ and the constant of proportionality in the $\mathcal{O}(\nu^{n+k})$ term is independent of j, k, n, Q and ξ . The proof of this is as follows.

Let $P = Q_j^k$, $P' = C_j^{\nu',k}$ and $S = \pi_{\nu'}^{-1}P'$. Then $G^{-(n+k)}P$ and $G^{-(n+k)}S$ are respectively of the form $\pi_{\nu}^{-1}D^{\nu}$ and $\pi_{\nu}^{-1}E^{\nu}$ for some cylinders D^{ν} and E^{ν} in T_G^{ν} with D^{ν} contained in E^{ν} . Moreover, the d_{ν} -length of E^{ν} is not greater than $2^{-(n+k)}$. Therefore, by inequality (4.3) for all ξ and η in $A^{\nu',k}$

$$\frac{r_{\xi}(D^{\nu} : E^{\nu})}{r_{\eta}(D^{\nu} : E^{\nu})} \in (1 \pm \mathcal{O}(\nu^{n+k})) \quad (6.6)$$

for some ν as above and where $r_{\xi}(D^{\nu} : E^{\nu}) = r^{\nu}(\xi \cap \pi_{\nu}^{-1}D^{\nu} : \xi \cap \pi_{\nu}^{-1}E^{\nu})$. Here $A^{\nu',k} \in \{A', B'\}$ is $\pi_{\nu'}(G^{-(n+k)}P)$. But then

$$\begin{aligned} \frac{\rho(P)}{\mu^*(P')} &= \frac{\rho(P)}{\rho(\pi_{\nu'}^{-1}P')} = \frac{\rho(\pi_{\nu}^{-1}D^{\nu})}{\rho(\pi_{\nu}^{-1}E^{\nu})} \\ &= \frac{\mu(D^{\nu})}{\mu(E^{\nu})} = \frac{\int r_{\xi}(D^{\nu})\mu^*(d\xi)}{\int r_{\xi}(E^{\nu})\mu^*(d\xi)} = \frac{\int r_{\xi}(D^{\nu} : E^{\nu})r_{\xi}(E^{\nu})\mu^*(d\xi)}{\int r_{\xi}(E^{\nu})\mu^*(d\xi)} \end{aligned}$$

where the integrals are all over $A^{\nu',k}$. By (6.6), we have

$$\frac{\int r_{\xi}(D^{\nu} : E^{\nu})r_{\xi}(E^{\nu})\mu^*(d\xi)}{\int r_{\xi}(E^{\nu})\mu^*(d\xi)} \in (1 \pm \mathcal{O}(\nu^{n+k})) r_{\eta}(D^{\nu} : E^{\nu})$$

for all $\eta \in A^{\nu',k}$. But if $\xi \in C_j^{\nu',k}$ then $\eta = m_{\nu'}^{n+k}\xi \in A^{\nu',k}$ and $r_{\xi}(Q) = r_{\eta}(D^{\nu} : E^{\nu})$ by G -invariance of the ratio function. Thus we deduce (6.5) as required.

Now we can complete the proof of the theorem by noting that

$$\begin{aligned} \rho(Q) &= \sum_j \rho(Q_j^k) = \sum_j (1 \pm \mathcal{O}(\nu^{n+k})) r_{\xi_j}(Q)\mu^*(C_j^{\nu',k}) \\ &\in (1 \pm \mathcal{O}(\nu^{n+k})) \sum_j r_{\xi_j}(Q)\mu^*(C_j^{\nu',k}). \end{aligned}$$

It follows that

$$\rho(Q) = \int r_{\xi}(Q)\mu^*(d\xi).$$

□

6.3 The dual affine structure on the stable lamination

We have seen above that a self-renormalizable structure \mathcal{S} on T_G^{ν} determines an affine structure on the ν -lamination given by a ν -ratio function and the 2-dimensional measure $\rho_{\mathcal{S}}^{\nu}$ on \mathbb{T} . We now construct a dual affine structure on the ν' lamination. These two

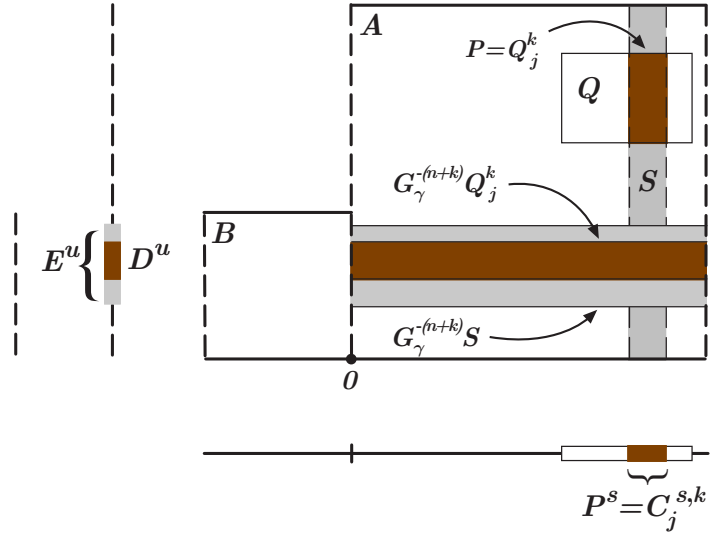

Figure 6.2: This figure shows schematically the form of the various sets used in the proof of Theorem 6.1.

affine structures determine a C^{1+} conjugacy class and ρ_S^t is the SRB measure for this conjugacy class and is absolutely continuous with respect to two-dimensional Lebesgue measure. Thus our strategy inverts the usual approach in that, instead of taking the given smooth structure and trying to find a measure that is absolutely continuous, we fix the measure and then construct the smooth structure in which it is absolutely continuous.

Let $(x_0, x_1, x_2) \in T^{\iota'}$ be three points in an extended ι' leaf segment x . We can regard x as an element of $T_G^{\iota'}$. Let C_n be a n -cylinder containing x . Let $\ell_x(x_0, x_1, x_2)$ be the segment in x determined by the three points. If ξ is a ι -leaf segment then let $C_n(\xi)$ be the segment in ξ that projects under π_ι onto C_n . Let $A_n(x_0, x_1, x_2)$ (resp. $B_n(x_0, x_1, x_2)$) be the union of the $C_n(\xi)$ where ξ is a ι leaf segment passing through a point in $\ell_x(x_0, x_1, x_2)$ between x_0 and x_1 (resp. x_1 and x_2) (see Figure 6.3). Define

$$r^{\iota,*}(x_0, x_1, x_2) = \lim_{n \rightarrow \infty} r_n^{\iota,*}(x_0, x_1, x_2) \tag{6.7}$$

where

$$r_n^{\iota,*}(x_0, x_1, x_2) = \frac{\rho_S^t(B_n)}{\rho_S^t(A_n)}.$$

Theorem 6.2 $r^{\iota,*}$ is a ι' -ratio function which we call the dual ratio function to r^ι . The dual of $r^{\iota,*}$ is r^ι . Furthermore, r^ι is affine if, and only if, $r^{\iota,*}$ is affine.

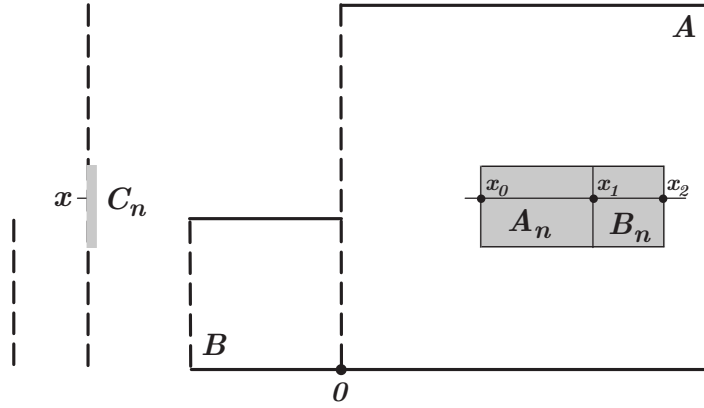

Figure 6.3: This figure shows how the dual ratio function is calculated. The three points are in the leaf x and their ratio is given by taking the limit of the ratios $\rho_S^t(B_n)/\rho_S^t(A_n)$.

Proof. Let ρ denote ρ_S^t . The main thing to prove is that, in the notation above,

$$\frac{\rho(B_{n+1})}{\rho(A_{n+1})} \in (1 \pm \mathcal{O}(\nu^n)) \frac{\rho(B_n)}{\rho(A_n)} \quad (6.8)$$

for some $0 < \nu < 1$ which is independent of n and (x_0, x_1, x_2) .

Let us consider the case where A_n and B_n are both contained in A or both in B . Since C_n is a n -cylinder of m_ι , $G_\iota^n A_n$ and $G_\iota^n B_n$ are both unions of ι -leaf segments. Let a_n and b_n be the segments in T_G^t consisting of these leaf segments. Then by Theorem 6.1,

$$\frac{\rho(A_{n+1})}{\rho(A_n)} = \frac{\int_{a_n} r_\xi(D_n) \mu^*(d\xi)}{\mu^*(a_n)} \in (1 \pm \mathcal{O}(\nu^n)) r_\eta(D_n)$$

where η is any element of a_n , D_n is the cylinder $\pi_\iota(G^n A_{n+1})$ and $0 < \nu < 1$ is as above. This is because $r_\xi(D_n)/r_\eta(D_n) \in (1 \pm \mathcal{O}(\nu^n))$ for any $\xi, \eta \in a_n$.

A similar inequality holds for $\rho(B_{n+1})/\rho(B_n)$ and therefore (6.8) holds.

The existence of the limit in (6.7) and the Hölder continuity of $r^{\iota,*}$ between leaves (inequality (4.2)) follows immediately from (6.8). The invariance of $r^{\iota,*}$ under G follows immediately from the G -invariance of ρ .

To see that the dual of $r = r^{\iota,*}$ is r^ι consider three points x, y and z on a ι -leaf ℓ . To check that $r(x, y, z) = r^\iota(x, y, z)$ in general, we may restrict to the case where x, y and z are all contained in a single element of $\{A, B\}$. Let $x^{(n)} = G^{-n}x$ and let $y^{(n)}$ and $z^{(n)}$ be similarly defined. Let A'_n (resp. B'_n) denote the union of all leaf segments through

the points on ℓ between $x^{(n)}$ and $y^{(n)}$ (resp. $y^{(n)}$ and $z^{(n)}$) and let $a'_n = \pi_\iota(A'_n)$ and $b'_n = \pi_\iota(B'_n)$. By the following Lemma 6.5, μ^* is the SRB measure on T'_G corresponding to r . Therefore, $\rho = \rho'_S = \rho'^{*,*}_S$ and

$$r(x, y, z) = \lim_{n \rightarrow \infty} \frac{\rho(B'_n)}{\rho(A'_n)} = \lim_{n \rightarrow \infty} \frac{\mu(b'_n)}{\mu(a'_n)} = r^\iota(x, y, z)$$

as required. \square

Recall the definition of $r^\iota_\xi(C)$ in Lemma 6.3 as $r^\iota(C^e \cap \xi : \xi)$. Similarly, we define the ratios $r^{*,*}_x(C)$ as $r^{*,*}(C_e \cap x : x)$ where C is a cylinder in T'_G , C_e is the union of all the leaf segments ξ in C and $x \in T'_G$.

Lemma 6.5 *The ratios $\mu^*(C)/r^{*,*}_x(C)$ where C is a cylinder in T'_G and $x \in T'_G$ and $x \in T'_G$ is such that $x \cap \pi_\iota^{-1}C \neq \emptyset$ are uniformly bounded away from 0 and ∞ .*

Proof. Let $A_n \in T'_G$ be a decreasing sequence of n -cylinders containing x . Let C_e be the union of the leaf segments ξ in C and A_n^e be the union of the leaf segments y in A_n . Let B_n be the intersection of C_e and A_n^e . Then

$$r^{*,*}_x(C) = \lim_{n \rightarrow \infty} \frac{\rho'_S(B_n)}{\rho'_S(A_n^e)}$$

and, by Theorem 6.2, $r^{*,*}_x(C)^{-1} \times (\rho'_S(B_n)/\rho'_S(A_n^e)) \in 1 \pm \mathcal{O}(\kappa^n)$ where $\kappa \in (0, 1)$ is a constant independent of C and n . It follows that

$$r^{*,*}_x(C) = \mathcal{O}(\rho'_S(B_1)/\rho'_S(A_1^e)).$$

But $\rho'_S(B_1) = \mu^*(C)$ and $\rho'_S(A_1^e)$ is bounded independent of A_1^e whence

$$r^{*,*}_x(C)/\mu^*(C)$$

is bounded away from 0 and ∞ . \square

6.4 The absolute continuity of the 2-dimensional SRB measure

Let \mathcal{S} be a self-renormalizable structure on T'_G . By Proposition 4.2, this determines the affine structure on the ι -lamination given by the ι -ratio function r^ι . By Theorem 6.2, the measure ρ'_S determined by \mathcal{S} in turn determines the affine structure on the ι' -lamination given by the ι' -ratio function $r^{\iota',*}$.

Theorem 6.3 *The HR structure $(r^\iota, r^{\iota,*})$ determines a unique C^{1+} conjugacy class of Anosov maps with the property that it gives $(r^\iota, r^{\iota,*})$. Furthermore, the SRB measure $\rho_{\mathcal{S}}^\iota$ is absolutely continuous with respect to two-dimensional Lebesgue measure.*

It follows from the proof of Theorem 6.3 that the HR (r^s, r^u) determines a canonical C^{1+} structure on \mathbb{T} . Furthermore, this canonical C^{1+} structure on \mathbb{T} has the property that the basic holonomies have the highest degree of smoothness in its C^{1+} conjugacy class. The SRB measure $\rho_{\mathcal{S}}^\iota$ is in fact proportional to two-dimensional Lebesgue measure in the sense that if \mathcal{A} is a bounded atlas of the structure and E a Borel set of \mathbb{T} then the ratio of $\rho_{\mathcal{S}}^\iota(E)$ to the Lebesgue measure of E in any chart of the atlas is bounded away from 0 and ∞ with the bounds only depending upon the atlas and not on the set E .

Proof. By Theorem 5.1 of [31], the HR structure $(r^\iota, r^{\iota,*})$ determines a unique C^{1+} conjugacy class of Anosov maps with the property that it gives $(r^\iota, r^{\iota,*})$. The smooth structure is defined as follows. Recall the definition of the local product structure map. Suppose that, for $y \in \mathbb{T}$, $\ell_\varepsilon^\iota(y)$ is the ε -neighbourhood of y in the ι -leaf through x in the metric d_ι . Then, for $\varepsilon > 0$ small there is a well-defined map

$$[\cdot, \cdot] : \ell_\varepsilon^s(x) \times \ell_\varepsilon^u(x) \rightarrow \mathbb{T}$$

where $[y, z]$ is the unique intersection point of $\ell_{2\varepsilon}^s(y)$ and $\ell_{2\varepsilon}^u(z)$. For $x \in \mathbb{T}$, let x_ι denote the endpoint $x \prec x_\iota$ of $\ell_\varepsilon^\iota(x)$. There are unique embeddings $c_\iota : \ell_\varepsilon^\iota(x) \rightarrow [0, 1] \in \mathbb{R}$ such that c_ι preserves the affine structures on $\ell_\varepsilon^\iota(x)$, sends x to 0 and x^ι to 1. Now define

$$i : \ell_\varepsilon^s(x) \times \ell_\varepsilon^u(x) \rightarrow \mathbb{R}^2$$

by $i([z_s, z_u]) = (c_s(z_s), c_u(z_u))$. This chart maps leaf segments to either a horizontal or a vertical line. This defines an atlas and gives the smooth structure of the theorem. This atlas is canonically associated with the HR structure. According to Theorem 5.1 of [31], G is a diffeomorphism in this structure. Thus the structure determines a C^{1+} conjugacy class with the required properties. Furthermore, the atlas maximises the smoothness of the holonomy maps amongst the C^{1+} equivalence classes follows from Theorem 5.3 of [31]. Now we show that $\rho_{\mathcal{S}}^\iota$ is smooth.

Suppose that R is a cylinder of G as defined in Section 6.2. We have,

$$\frac{\rho_{\mathcal{S}}^\iota(R)}{\mu(\pi_\iota R)} = \int_{\pi_{\iota'} R} \frac{r_\xi^\iota(\pi_\iota R)}{\mu(\pi_\iota R)} \mu^*(d\xi) = \mathcal{O}(\mu^*(\pi_{\iota'} R))$$

because $r'_\xi(\pi_\iota R) = \mathcal{O}(\mu(\pi_\iota R))$ by Lemma 6.4. Consequently,

$$\rho'_S(R) = \mathcal{O}(\mu(\pi_\iota R)\mu^*(\pi_{\iota'} R)).$$

Combining this with Lemma 6.4 and Lemma 6.5, it follows that

$$\rho'_S(R) = \mathcal{O}(r'_\xi(\pi_\iota R)r_{\iota,x}^*(\pi_{\iota'} R)).$$

Therefore, if R is contained inside a chart $i : U \rightarrow \mathbb{R}^2$ of the atlas \mathcal{A} above, $\rho'_S(R)/\lambda(i(R))$ is bounded away from 0 and ∞ uniformly for all such R . This proves that ρ'_S is smooth.

□

6.5 Absolute continuity implies duality of the affine structures

Lemma 6.6 *If the SRB measure ρ of f is absolutely continuous with respect to Lebesgue measure then r^s is the dual of r^u .*

Proof. Let $(x, y, z) \in T^s$ and let A_n, B_n and C_n be the sets used in the definition of the value of the dual ratio function at (x, y, z) . Let us consider the case where the points x, y and z are all contained in either A or B . Then $G^n A_n$ and $G^n B_n$ are both unions of leaf segments because C_n is a n -cylinder of m_u . Let a_n and b_n be the sets in T_G^s consisting of these leaf segments. Then by the invariance of ρ , $\rho(A_n)/\rho(B_n) = \mu^s(a_n)/\mu^s(b_n)$ and therefore

$$(r^u)^*(x, y, z) = \lim_{n \rightarrow \infty} \frac{\mu^s(a_n)}{\mu^s(b_n)}.$$

Since ρ is absolutely continuous with respect to Lebesgue measure, we obtain that ρ is the SRB measure for both G and G^{-1} in \mathcal{S} . Thus, the projection μ^s of ρ onto T_G^s is absolutely continuous in the structure \mathcal{S}^s on T_G^s . Thus μ^s is the SRB measure for the Markov map m_s . Hence, by Lemma 6.2 applied to \mathcal{S}^s ,

$$\lim_{n \rightarrow \infty} \mu^s(a_n)/\mu^s(b_n) = \lim_{n \rightarrow \infty} |a_n|/|b_n|$$

where the lengths are measured in the submanifold structure of the stable leaves. Therefore $(r^u)^* = r^s$. □

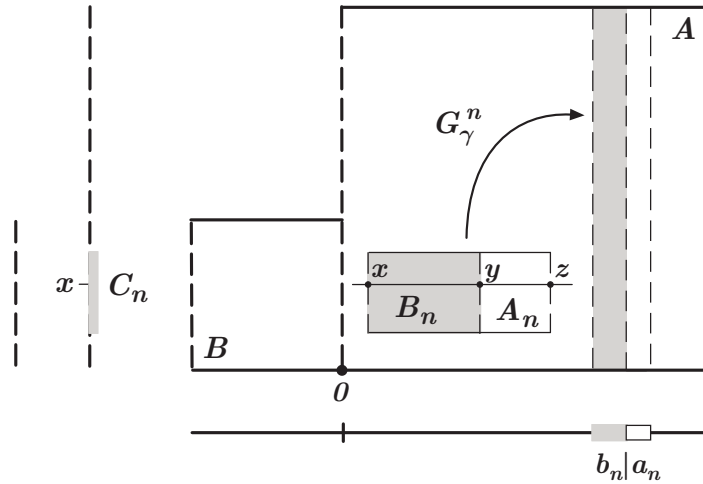

Figure 6.4: This figure shows the construction of the sets a_n and b_n in the proof of Lemma 6.6.

Theorem 6.4 (Flexibility) *The map $G \mapsto \mathcal{S}(G)$ determines a one-to-one correspondence between C^{1+} Anosov diffeomorphisms whose SRB measure is absolutely continuous with respect to two dimensional Lebesgue measure and C^{1+} self-renormalizable structures.*

Proof. Given a C^{1+} Anosov diffeomorphism, by Lemma 6.6, if the SRB measure ρ is absolutely continuous with respect to Lebesgue measure then r^s is the dual of r^u . Furthermore, by Lemma 3.4 the map G determines a unique C^{1+} self-renormalizable structure $\mathcal{S}(G)$ on T_G^l . Conversely, by Proposition 4.2 a C^{1+} self-renormalizable structure \mathcal{S} on T_G^l determines a ι -ratio function r^ι . By Proposition 6.1 the self-renormalizable structure \mathcal{S} on T_G^l determines a unique measure $\mu = \mu_{\mathcal{S}}$ which is m_ι -invariant and absolutely continuous with respect to the lengths determined by any bounded atlas of \mathcal{S} . By Theorem 6.2, r^ι determines a dual ι' -ratio function $r^{\iota,*}$ and by Theorem 6.3, the HR structure $(r^\iota, r^{\iota,*})$ determines a unique C^{1+} conjugacy class of Anosov maps with the property that it gives $(r^\iota, r^{\iota,*})$. Furthermore, the SRB measure $\rho_{\mathcal{S}}$ is absolutely continuous with respect to two-dimensional Lebesgue measure. \square

By Theorem 3.1, there is a well defined map $g \mapsto \mathcal{S}(g)$ that determines a one-to-one correspondence between C^{1+} circle diffeomorphisms that are C^{1+} fixed points of renormalization and the induced C^{1+} self-renormalizable structures. By Theorem 6.4, there is a well defined map $\mathcal{S} \mapsto G(\mathcal{S})$ that determines a one-to-one correspondence between C^{1+} self-renormalizable structures and the induced C^{1+} Anosov diffeomorphisms

with SRB measure absolutely continuous with respect to two dimensional Lebesgue measure. Putting together Theorem 3.1 and Theorem 6.4 we obtain the following corollary.

Corollary 6.1 *The map $g \mapsto G(\mathcal{S}(g))$ induces a one-to-one correspondence between C^{1+} fixed points of renormalization g and C^{1+} Anosov diffeomorphisms $G(\mathcal{S}(g))$ with an invariant measure that is absolutely continuous with respect to Lebesgue measure.*

Putting together Theorem 4.2 and Corollary 6.1 we obtain the following corollary.

Corollary 6.2 *The map $G \rightarrow r_G^u$ determines a one-to-one correspondence between C^{1+} conjugacy classes of Anosov diffeomorphisms G in \mathcal{G} and unstable ratio functions.*

Let \mathcal{SOL} be the set consisting of all (unstable) solenoid functions. The set \mathcal{SOL} has a natural metric. Combining Lemma 6.2 and Lemma 5.3, we obtain the following corollary.

Corollary 6.3 *The map $G \rightarrow r_G|_{\mathbf{sol}}$ determines a one-to-one correspondence between C^{1+} conjugacy classes of Anosov diffeomorphisms G in \mathcal{G} and solenoid functions $r_G|_{\mathbf{sol}}$ in \mathcal{SOL} .*

Chapter 7

Tilings

In this chapter we link Anosov diffeomorphisms with a certain type of sequences of natural numbers that we will call γ -sequences.

As in Chapter 2, let us fix a positive integer $a \in \mathbb{N}$ and let $\gamma = (-a + \sqrt{a^2 + 4})/2 = 1/(a + 1/(a + 1/\dots))$. We recall that the key feature of γ is that it satisfies the relation $a\gamma + \gamma^2 = 1$. We consider the Anosov automorphism $G_\gamma : \mathbb{T} \rightarrow \mathbb{T}$ given by $G_\gamma(x, y) = (ax + y, x)$, where \mathbb{T} is equal to $\mathbb{R}^2/(v\mathbb{Z} \times w\mathbb{Z})$ with $v = (\gamma, 1)$ and $w = (-1, \gamma)$. Recall from Chapter 3 that a $C^{1+\alpha}$ Anosov diffeomorphism $G : \mathbb{T} \rightarrow \mathbb{T}$ is a $C^{1+\alpha}$ diffeomorphism, with $\alpha > 0$, such that (i) G is topologically conjugate to G_γ ; (ii) the tangent bundle has a $C^{1+\alpha}$ uniformly hyperbolic splitting into a stable direction and an unstable direction. We denote by \mathcal{G} be the set of all such $C^{1+\alpha}$ Anosov diffeomorphisms with an invariant measure absolutely continuous with respect to the Lebesgue measure. The eigenvalues of the Anosov automorphism G_γ are $\mu^- = -\gamma$ and $\mu^+ = 1/\gamma$. Let $\pi : \mathbb{R}^2 \rightarrow \mathbb{T}$ be the natural projection of \mathbb{R}^2 in \mathbb{T} . As in Chapter 3, a Markov partition \mathcal{M}_γ of G_γ is given by $A = \pi(\tilde{A})$ and $B = \pi(\tilde{B})$, where \tilde{A} and \tilde{B} are the rectangles $[0, 1] \times [0, 1]$ and $[-\gamma, 0] \times [0, \gamma]$ respectively. The unstable manifolds of G_γ correspond to the projection by π of the vertical lines of the plane, and the stable manifolds of G_γ are the projection by π of the horizontal lines of the plane.

Let W_0 be the positive vertical axis of \mathbb{R}^2 . Hence $W = \pi(W_0)$ is the unstable leaf of G_γ with only one endpoint $y_0 = \pi(0, 0)$ that is the fixed point of G_γ . The unstable leaf W passes, firstly, through all the unstable boundaries of the Markov rectangles A and B . Let the unstable spanning leaf segment K_1 be the left unstable boundary of the Markov rectangle A (see the definition of spanning leaf segment in Section 3.1). Let

the unstable spanning leaf segment K_2 be the left unstable boundary of the Markov rectangle B . Let $K_3, K_4, \dots \in W$ be the unstable leaf segments defined, inductively, as follows: (i) K_i is an unstable spanning leaf of a Markov rectangle, for every $i \geq 3$; (ii) $K_i \cap K_{i+1} = \{y_i\}$ is a common boundary point of both K_i and K_{i+1} , for every $i \geq 2$. We note that $W = \cup_{i \geq 1} K_i$.

Let $h = h_G : \mathbb{T} \rightarrow \mathbb{T}$ be the topological conjugacy between the Anosov automorphism G_γ and the C^{1+} Anosov diffeomorphism G . Let \mathcal{M}_γ be a Markov partition of G_γ . We observe that the rectangles $h(A)$ and $h(B)$ form a Markov partition \mathcal{M}_G of G .

Theorem 7.1 (*Flexibility*) *There is a well-defined map $G \rightarrow (a_{G,i})_{i \in \mathbb{N}}$ that associates to each C^{1+} Anosov diffeomorphism $G \in \mathcal{G}$ the γ -sequence $(a_{G,i})_{i \in \mathbb{N}}$ given by*

$$a_{G,i} = \lim_{n \rightarrow \infty} \frac{|G^{-n}(h(K_{i+1}))|}{|G^{-n}(h(K_i))|},$$

where $|I|$ is the length of the unstable leaf segment I with respect to a Riemannian metric on \mathbb{T} . Furthermore, this map determines a one-to-one correspondence between smooth conjugacy classes of Anosov diffeomorphisms in \mathcal{G} and γ -sequences.

Later, in Definition 7.2, we give the precise definition of γ -sequence and the proof of Theorem 7.1 is given in Section 7.7.

Let the γ -Fibonacci sequence $(F_n)_{n \in \mathbb{N}}$ be the sequence of natural numbers defined recursively by

$$F_1 = 1, \quad F_2 = a + 1, \quad \text{and} \quad F_{n+2} = aF_{n+1} + F_n, \quad \text{for } n \geq 1.$$

We observe that if $a = 1$, then $(F_i)_{i \in \mathbb{N}}$ is the well known Fibonacci sequence. For any natural number $i \in \mathbb{N}$, we define the finite sequence $\tilde{F}_{n_0}, \tilde{F}_{n_1}, \dots, \tilde{F}_{n_q}$ as follows: (i) \tilde{F}_{n_0} is the largest term in the γ -Fibonacci sequence that is less or equal to i ; (ii) inductively, if $\tilde{F}_{n_0} + \dots + \tilde{F}_{n_{k-1}} < i$ then \tilde{F}_{n_k} is the largest term in the γ -Fibonacci sequence that is less or equal to $i - (\tilde{F}_{n_0} + \dots + \tilde{F}_{n_{k-1}})$. We observe that there is a natural number $q \in \mathbb{N}$ and a term in the γ -Fibonacci sequence such that $i = \tilde{F}_{n_0} + \dots + \tilde{F}_{n_q}$.

We observe that if $a = 1$ then any term of the γ -Fibonacci sequence $(F_n)_{n \in \mathbb{N}}$ appears at most once in the sequence $\tilde{F}_{n_0}, \tilde{F}_{n_1}, \dots, \tilde{F}_{n_q}$. Hence, setting $F_{n_k} = \tilde{F}_{n_k}$ for $k \in \{0, \dots, q\}$, we have

$$i = F_{n_1} + F_{n_2} + \dots + F_{n_q}$$

and, in this case, we call $(F_{n_1}, F_{n_2}, \dots, F_{n_q})$ the *Fibonacci decomposition* of $i \in \mathbb{N}$ (see [25]). If $a > 1$ then any term of the γ -Fibonacci sequence $(F_n)_{n \in \mathbb{N}}$ repeats at most a times in the sequence $\tilde{F}_{n_0}, \tilde{F}_{n_1}, \dots, \tilde{F}_{n_q}$, for any natural number $i \in \mathbb{N}$.

We define the finite sequence of γ -Fibonacci numbers $F_{n_0}, F_{n_1}, \dots, F_{n_p}$, with $p \leq q$, such that

$$i = a_{n_0}F_{n_0} + \dots + a_{n_p}F_{n_p},$$

where $a_{n_k} \in \{1, \dots, a\}$, for every $k \in \{0, \dots, p\}$.

We call the sequence $(a_{n_0}F_{n_0}, \dots, a_{n_p}F_{n_p})$ the γ -*Fibonacci decomposition* of $i \in \mathbb{N}$. We observe that every natural number $i \in \mathbb{N}$ has a unique γ -Fibonacci decomposition.

Definition 7.1 *The rigid γ -sequence $(a_{\gamma,i})_{i \in \mathbb{N}}$ is defined as follows: For every $i \in \mathbb{N}$, with γ -Fibonacci decomposition $(a_{n_0}F_{n_0}, \dots, a_{n_p}F_{n_p})$, we define*

(i) $a_{\gamma,i} = \gamma^{-1}$, if one of the following conditions is satisfied:

$$n_p = 1, a_p = 1 \text{ and } n_{p-1} \text{ is odd};$$

$$n_p = 1, a_p = 2 \text{ and } n_{p-1} \text{ is even.}$$

(ii) $a_{\gamma,i} = \gamma$, if one of the following conditions is satisfied:

$$n_p = 1, a_p = 1 \text{ and } n_{p-1} \text{ is even};$$

$$n_p \geq 2 \text{ and } n_p \text{ is odd.}$$

(iii) $a_{\gamma,i} = 1$, if one of the following conditions is satisfied:

$$n_p = 1, a_p = 2 \text{ and } n_{p-1} \text{ is odd};$$

$$n_p = 1, a_p > 2;$$

$$n_p \geq 2 \text{ and } n_p \text{ is even.}$$

Remark 7.1 *If $a = 1$ then the Fibonacci decomposition of a natural number $i \in \mathbb{N}$ is $(F_{n_1}, F_{n_2}, \dots, F_{n_p})$. Hence, $a_p = 1$ and the rigid γ -sequence $(a_{\gamma,i})_{i \in \mathbb{N}}$ is defined as follows (see [25]):*

(i) $a_{\gamma,i} = \gamma^{-1}$ if either $(n_p = 1 \text{ and } n_{p-1} \text{ is odd})$ or $(n_p = 2 \text{ and } n_{p-1} \text{ is even})$;

(ii) $a_{\gamma,i} = \gamma$ if either $(n_p = 1 \text{ and } n_{p-1} \text{ is even})$ or $(n_p > 2 \text{ and } n_p \text{ is odd})$;

(iii) $a_{\gamma,i} = 1$ if either $(n_p = 2 \text{ and } n_{p-1} \text{ is odd})$ or $(n_p > 2 \text{ and } n_p \text{ is even})$.

In Theorem 7.1 it is proved the existence of an infinite dimensional space of well-characterized γ -sequences. However, we are only able to explicit the rigid γ -sequence.

Theorem 7.2 (Rigidity) *Every Anosov diffeomorphism $G \in \mathcal{G}$ with a $C^{1+\text{zygmund}}$ complete system of unstable holonomies determines a rigid γ -sequence $(a_{G,i})_{i \in \mathbb{N}}$.*

The definition of a $C^{1+\text{zygmund}}$ complete system of unstable holonomies and the proof of Theorem 7.2 are given in Section 7.8.

7.1 Realized γ -sequences

the unstable leaf segments K_1, K_2, \dots , and the unstable leaf $W = \cup_{i \geq 1} K_i$. By construction, the set

$$\mathcal{L} = \{(K_i, K_{i+1}), i \in \mathbb{N}\}$$

is contained in **sol** and it is dense in **sol**.

Recall that $h : \mathbb{T} \rightarrow \mathbb{T}$ is the topological conjugacy between the Anosov automorphism G_γ and the C^{1+} Anosov diffeomorphism G .

Lemma 7.1 *There is well-defined map $G \rightarrow (a_{G,i})_{i \in \mathbb{N}}$ that associates to each C^{1+} Anosov diffeomorphism G in \mathcal{G} the sequence $(a_{G,i})_{i \in \mathbb{N}}$ given by*

$$a_{G,i} = \lim_{n \rightarrow \infty} \frac{|G^{-n}(h(K_{i+1}))|}{|G^{-n}(h(K_i))|}.$$

where $|I|$ denotes the length of the unstable leaf segment I with respect to a Riemannian metric on \mathbb{T} .

Proof. By Lemma 5.3 and by equation (4.5), we get that $\sigma_G(K_i : K_{i+1}) = r_G^u(K_i : K_{i+1})$, where

$$r_G^u(K_i : K_{i+1}) = \lim_{n \rightarrow \infty} \frac{|G^{-n}(h(K_{i+1}))|}{|G^{-n}(h(K_i))|},$$

is well-defined. Since, by construction, $a_{G,i} = r_G^u(K_i : K_{i+1})$, we get that $a_{G,i}$ is well-defined and $a_{G,i} = \sigma_G(K_i : K_{i+1})$. \square

Lemma 7.2 *For every $i \in \mathbb{N}$ with γ -Fibonacci decomposition $(a_{n_0}F_{n_0}, \dots, a_{n_p}F_{n_p})$ the following conditions hold*

- (i) $K_i \in B$ and $K_{i+1} \in A$, if either ($n_p = 1$, $a_p = 1$ and n_{p-1} is odd) or ($n_p = 1$, $a_p = 2$ and n_{p-1} is even);
- (ii) $K_i \in A$ and $K_{i+1} \in B$, if either ($n_p = 1$, $a_p = 1$ and n_{p-1} is even) or ($n_p \geq 2$ and n_p is odd);
- (iii) $K_i, K_{i+1} \in A$, if either ($n_p = 1$, $a_p = 2$ and n_{p-1} is odd) or ($n_p \geq 2$ and n_p is even).

Proof. If $a = 1$ see the proof of Lemma 7.2 in [25]. Let us consider an integer $a > 1$. Let $\pi : \mathbb{R}^2 \rightarrow \mathbb{T}$ be the natural projection, where $\mathbb{T} = \mathbb{R}^2 / (v\mathbb{Z} \times w\mathbb{Z})$. Let $\mathbb{S} = \mathbb{R} / [1 + \gamma]\mathbb{Z}$ be the clockwise oriented circle with the metric induced by the Euclidean metric on \mathbb{R} . Let $\pi_{\mathbb{S}} : \mathbb{R} \rightarrow \mathbb{S}$ be the natural projection. The projection $\pi_{\mathbb{S}}$ has the property that

$$\pi_{\mathbb{S}}(x) = \pi_{\mathbb{S}}(x + 1 + \gamma),$$

for every $x \in \mathbb{R}$. Let $i_{\mathbb{S}} : \mathbb{S} \rightarrow \mathbb{T}$ be the natural inclusion. The inclusion $i_{\mathbb{S}}$ has the property that

$$\pi(x, 0) = i_{\mathbb{S}} \circ \pi_{\mathbb{S}}(x),$$

for every $x \in \mathbb{R}$. Recall that K_0 is the unstable spanning leaf segment such that $K_0 \cap K_1 = \{y_0\}$, where $y_0 = \pi(0, 0)$, and let K_1, K_2, \dots , be the unstable spanning leaf segments such that $W = \cup_{i \geq 1} K_i$. For every $i \in \mathbb{N}_0$, (i) let $y_i \in \mathbb{T}$ be the point given by $\{y_i\} = K_i \cap K_{i+1}$; (ii) let $z_i = i_{\mathbb{S}}^{-1}(y_i)$; and (iii) let $w_i \in [-1, \gamma]$ be such that $\pi_{\mathbb{S}}(w_i) = z_i$. Hence, for every $i \in \mathbb{N}_0$ (see Figure 7.1),

- (i) if $w_i \in (-\gamma, 0)$ then $K_i \in A$ and $K_{i+1} \in B$;
- (ii) if $w_i \in [-1, -2\gamma) \cup (0, \gamma]$ then $K_i, K_{i+1} \in A$;
- (iii) if $w_i \in (-2\gamma, -\gamma)$ then $K_i \in B$ and $K_{i+1} \in A$.

Let $g : \mathbb{S} \rightarrow \mathbb{S}$ be the rigid rotation with rotation number $\gamma / (1 + \gamma)$. The map g has the property that

$$g \circ \pi_{\mathbb{S}}(x) = \pi_{\mathbb{S}}(x + \gamma),$$

for every $x \in \mathbb{R}$. Since $G_{\gamma} : \mathbb{T} \rightarrow \mathbb{T}$ is the Anosov automorphism, we obtain that $g(z_i) = z_{i+1}$, for every $i \in \mathbb{N}_0$. Let us denote by $\ell(y_0, y_i)$ the leaf segment with endpoints y_0 and y_i . Since $G_{\gamma} : \mathbb{T} \rightarrow \mathbb{T}$ is the Anosov automorphism, if the leaf $\ell(y_0, y_i)$ contains m_{γ} spanning leaf segments of the Markov rectangle A and m_B spanning leaf segments of

the Markov rectangle B then $G_\gamma(\ell(y_0, y_i)) = \ell(y_0, G_\gamma(y_i))$ contains $am_\gamma + m_B$ spanning leaf segments of the Markov rectangle A and m_γ spanning leaf segments of the Markov rectangle B . Hence, by induction, we have that $G_\gamma(y_{F_i}) = y_{F_{i+1}}$, where F_1, F_2, \dots , is the γ -Fibonacci sequence. Thus, for every $i \in \mathbb{N}$, we have that $G_\gamma^{i-1}(y_1) = y_{F_i}$, and, so, $d(y_0, y_{F_i}) = \gamma^i$ and $\pi((-\gamma)^i, 0) = y_{F_i}$. Thus $g^{F_i}(z_0) = z_{F_i} = \pi_\mathbb{S}((-\gamma)^i)$. Since g is the rigid rotation, we have that

$$g^{F_i}(\pi_\mathbb{S}(x)) = \pi_\mathbb{S}(x + (-\gamma)^i), \quad (7.1)$$

for every $x \in \mathbb{R}$ and $i \in \mathbb{N}$. Hence, for every $i \in \mathbb{N}$ with γ -Fibonacci decomposition $(a_0F_{n_0}, \dots, a_pF_{n_p})$, we obtain

$$z_i = g^i(z_0) = g^{a_0F_{n_0} + \dots + a_pF_{n_p}}(z_0).$$

Thus, by equality (7.1), we have that

$$g^{a_0F_{n_0} + \dots + a_pF_{n_p}}(z_0) = \pi_\mathbb{S} \left(\sum_{i=0}^p a_i (-\gamma)^{n_i} \right).$$

Noting that $\sum_{i=0}^{+\infty} \gamma^{2i} = (1 - \gamma^2)^{-1} = \gamma^{-1}$, we obtain

$$\sum_{i=0}^p a_i (-\gamma)^{n_i} < \sum_{j \geq 0} a \gamma^{2+2j} = \gamma$$

and

$$\sum_{i=0}^p a_i (-\gamma)^{n_i} > \sum_{j \geq 0} -a \gamma^{1+2j} = -1.$$

Therefore, taking $w_i = \sum_{j=0}^p a_j (-\gamma)^{n_j} \in [-1, \gamma]$ we obtain that $\pi_\mathbb{S}(w_i) = z_i$. Now, there are six distinct cases to consider depending upon the γ -Fibonacci decomposition $(a_0F_{n_0}, \dots, a_pF_{n_p})$ of i (see Figure 7.2):

- (i) if $n_p = 1$, $a_p = 1$ and n_{p-1} is odd then $w_i \in (-(\gamma + \gamma^2), -\gamma)$ and so $K_i \in B$ and $K_{i+1} \in A$;
- (ii) if $n_p = 1$, $a_p = 1$ and n_{p-1} is even then $w_i \in (-\gamma, -\gamma^2)$ and so $K_i \in A$ and $K_{i+1} \in B$;
- (iii) if $n_p = 1$, $a_p = 2$ and n_{p-1} is odd then $w_i \in (\gamma^3, \gamma^2)$ and so $K_i, K_{i+1} \in A$;
- (iv) if $n_p = 1$, $a_p = 2$ and n_{p-1} is even then $w_i \in (-2\gamma^2, -2\gamma + \gamma^2)$ and so $K_i \in B$ and $K_{i+1} \in A$;

- (v) if $n_p \geq 2$ and n_p is odd then $w_i \in (-\gamma^2, 0)$ and so $K_i \in A$ and $K_{i+1} \in B$;
- (vi) if $n_p \geq 2$ and n_p is even then $w_i \in (0, \gamma^3)$ and so $K_i, K_{i+1} \in A$.

□

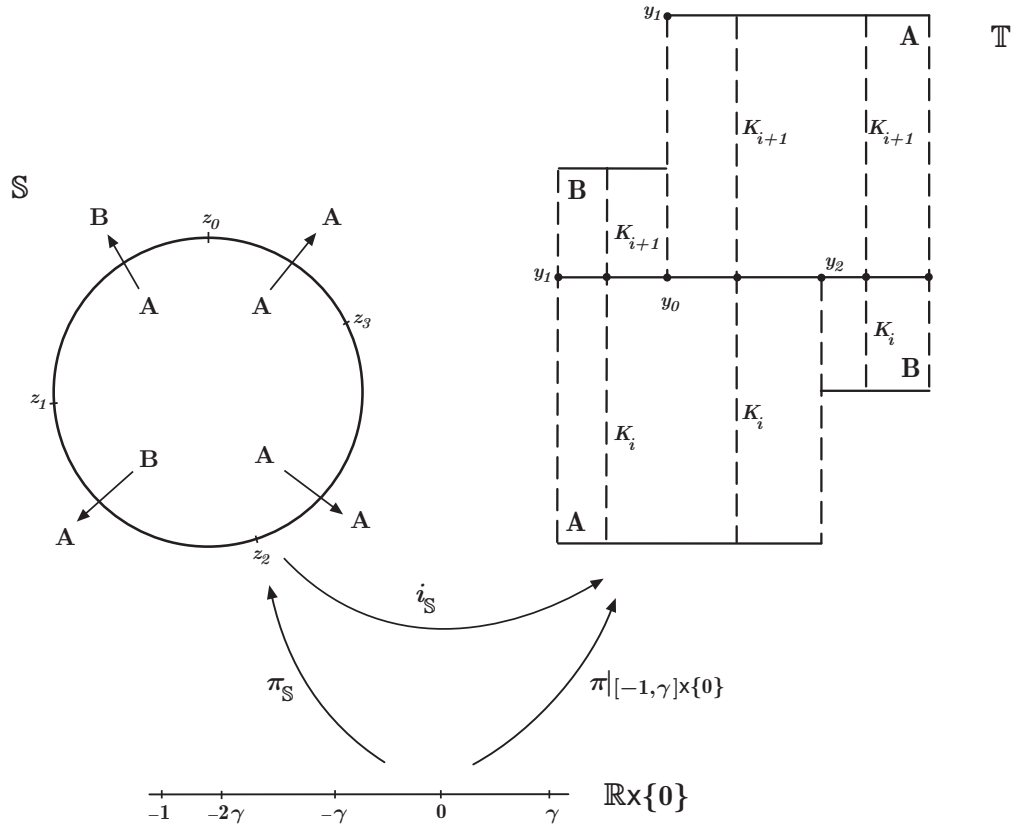

Figure 7.1: The map $i_S \circ \pi_S$.

7.2 The γ -Fibonacci shift

For every $i \in \mathbb{N}$, let $(a_{n_0}F_{n_0}, \dots, a_{n_p}F_{n_p})$ be the γ -Fibonacci decomposition associated to i , i.e.

$$i = a_{n_0}F_{n_0} + \dots + a_{n_p}F_{n_p}$$

We note that in what follows if $a = 1$ then F_2 has the properties of $2F_1$ (and not the properties of F_n for $n > 2$).

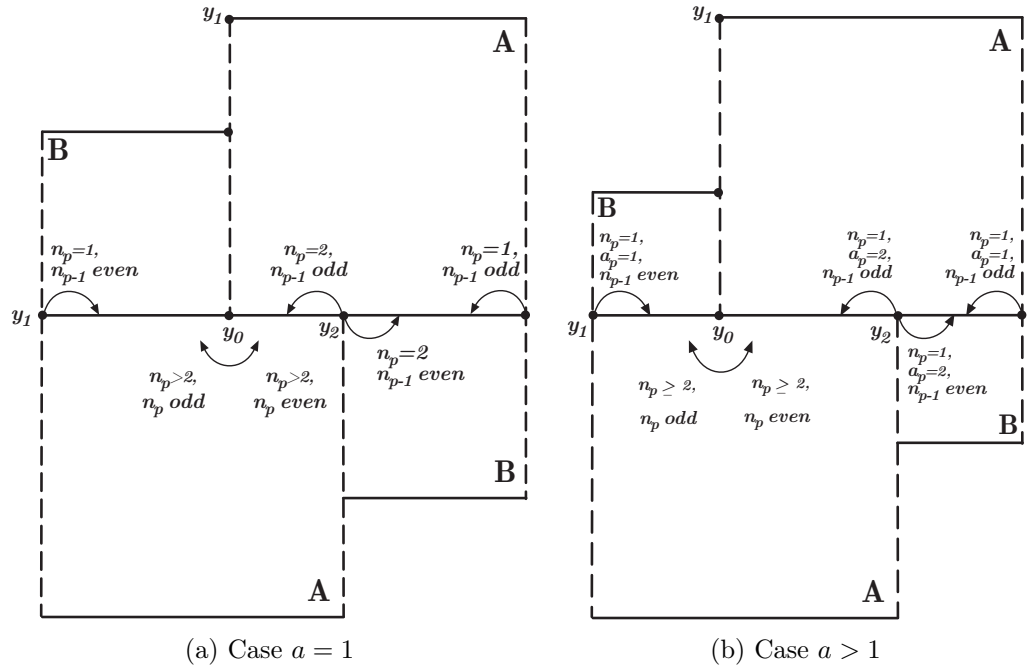

Figure 7.2: The location of the point y_i depending upon the Fibonacci decomposition of i .

The γ -Fibonacci shift $\sigma : \mathbb{N} \rightarrow \mathbb{N}$ is defined by

- (i) $\sigma(i) = a_{n_0}F_{n_0+1} + \cdots + a_{n_p}F_{n_{p-1}+1} + F_1$, if $n_p = 1$, $a_{n_p} = 1$ and n_{p-1} is odd;
- (ii) $\sigma(i) = a_{n_0}F_{n_0+1} + \cdots + a_{n_p}F_{n_{p-1}+1} + F_2$, if $n_p = 1$, $a_{n_p} = 1$ and n_{p-1} is even;
- (iii) $\sigma(i) = a_{n_0}F_{n_0+1} + \cdots + a_{n_p}F_{n_{p-1}+1} + (a_{n_p} - 1)F_2 + F_1$, if $n_p = 1$, $a_{n_p} \geq 2$ and n_{p-1} is even;
- (iv) $\sigma(i) = a_{n_0}F_{n_0+1} + \cdots + a_{n_p}F_{n_{p-1}+1} + a_{n_p}F_{n_p+1}$, if $n_p > 1$.

The inverse of the γ -Fibonacci shift $\sigma^{-1} : \mathbb{N} \rightarrow \mathbb{N}$ is defined by

- (i) $\sigma^{-1}(i) = \emptyset$, if $n_p = 1$, $a_{n_p} = 1$ and n_{p-1} is odd;
- (ii) $\sigma^{-1}(i) = a_{n_0}F_{n_0-1} + \cdots + a_{n_p}F_{n_{p-1}-1} + F_1$, if $n_p = 1$, $a_{n_p} = 1$ and n_{p-1} is even;
- (iii) $\sigma^{-1}(i) = \emptyset$, if $n_p = 1$, $a_{n_p} \geq 2$ and n_{p-1} is even;
- (iv) $\sigma^{-1}(i) = a_{n_0}F_{n_0-1} + \cdots + a_{n_p}F_{n_{p-1}-1} + a_{n_p}F_{n_p-1}$, if $n_p > 1$.

Remark 7.2 We observe that for $F_{n_p} = F_1$ the definition of the γ -Fibonacci shift is somewhat unnatural. This is due to the fact that we consider, for simplicity, the γ -Fibonacci sequence $F_1 = 1, F_2 = a + 1, \dots$ instead of the sequence $F_0 = 1, F_1 = 1, F_2 = a + 1, \dots$. If we consider the sequence $F_0 = 1, F_1 = 1, F_2 = a + 1, \dots$ then we have to change the γ -Fibonacci decomposition of the number i accordingly with the following rule: Suppose that $F_{n_{p-2}} \geq F_2$ and $i - (a_{n_0}F_{n_0} + \dots + a_{n_{p-1}}F_{n_{p-2}}) = b \leq a$;

1. if $b > 1$ then $(b - 1)F_{n_p} + F_{n_p} = (b - 1)F_1 + F_0$;
2. if $b = 1$ and n_{p-1} is odd then $F_{n_p} = F_0$; and
3. if $b = 1$ and n_{p-1} is even then $F_{n_p} = F_1$.

For every $i \in \mathbb{N}$, we define $\sigma(i) = F_{n_0+1} + \dots + F_{n_{p-1}+1} + F_{n_p+1}$. We get that if $n_p > 0$ then $\sigma^{-1}(i) = F_{n_0-1} + \dots + F_{n_{p-1}}$, and if $n_p = 0$ then $\sigma^{-1}(i) = \emptyset$. We claim that for this new γ -Fibonacci decomposition all the statements in this chapter will hold with the corresponding simple alterations.

7.3 Matching condition

We say that a sequence $(a_i)_{i \in \mathbb{N}}$ satisfies the *matching condition* if, for every $i = a_{n_0}F_{n_0} + \dots + a_{n_p}F_{n_p}$, the following conditions hold (see Figure 7.3):

- (i) If either $(n_p = 1, a_p = 1$ and n_{p-1} is even) or $(n_p \geq 2$ and n_p is odd), then

$$a_{\sigma(i)} = a_i \left(1 + \sum_{j=1}^a \prod_{k=1}^j a_{\sigma(i)+k} \right)^{-1}.$$

- (ii) If either $(n_p = 1, a_p = 1$ and n_{p-1} is odd) or $(n_p = 1, a_p = 2$ and n_{p-1} is even), then

$$a_{\sigma(i)} = a_i \left(1 + \sum_{j=1}^a \prod_{k=1}^j a_{\sigma(i)-k}^{-1} \right).$$

- (iii) If either $(n_p = 1, a_p = 2$ and n_{p-1} is odd) or $(n_p \geq 2$ and n_p is even), then

$$a_{\sigma(i)} = a_i \left(1 + \sum_{j=1}^a \prod_{k=1}^j a_{\sigma(i)-k}^{-1} \right) \left(1 + \sum_{j=1}^a \prod_{k=1}^j a_{\sigma(i)+k} \right)^{-1}.$$

Lemma 7.3 *The sequence $(a_{G,i})_{i \in \mathbb{N}}$ satisfies the matching condition.*

Proof. By Lemma 7.1, we have that $a_{G,i} = \sigma_G(K_i : K_{i+1})$, for every $i \in \mathbb{N}$. Hence Lemma 7.3 follows from putting together Lemma 5.1 and Lemma 7.2. \square

Remark 7.3 *Every sequence $(b_i)_{i \in \mathbb{N} \setminus \sigma(\mathbb{N})}$ determines, uniquely, a sequence $(a_i)_{i \in \mathbb{N}}$ satisfying the matching condition as follows: for every $i \in \mathbb{N} \setminus \sigma(\mathbb{N})$, define $a_i = b_i$ and, for every $i \in \sigma(\mathbb{N})$, define $a_{\sigma(i)}$ using the matching condition and the elements a_j of the sequence with*

$$j \in \{j : 2 \leq j < \sigma(i) \vee j \in \mathbb{N} \setminus \sigma(\mathbb{N})\}.$$

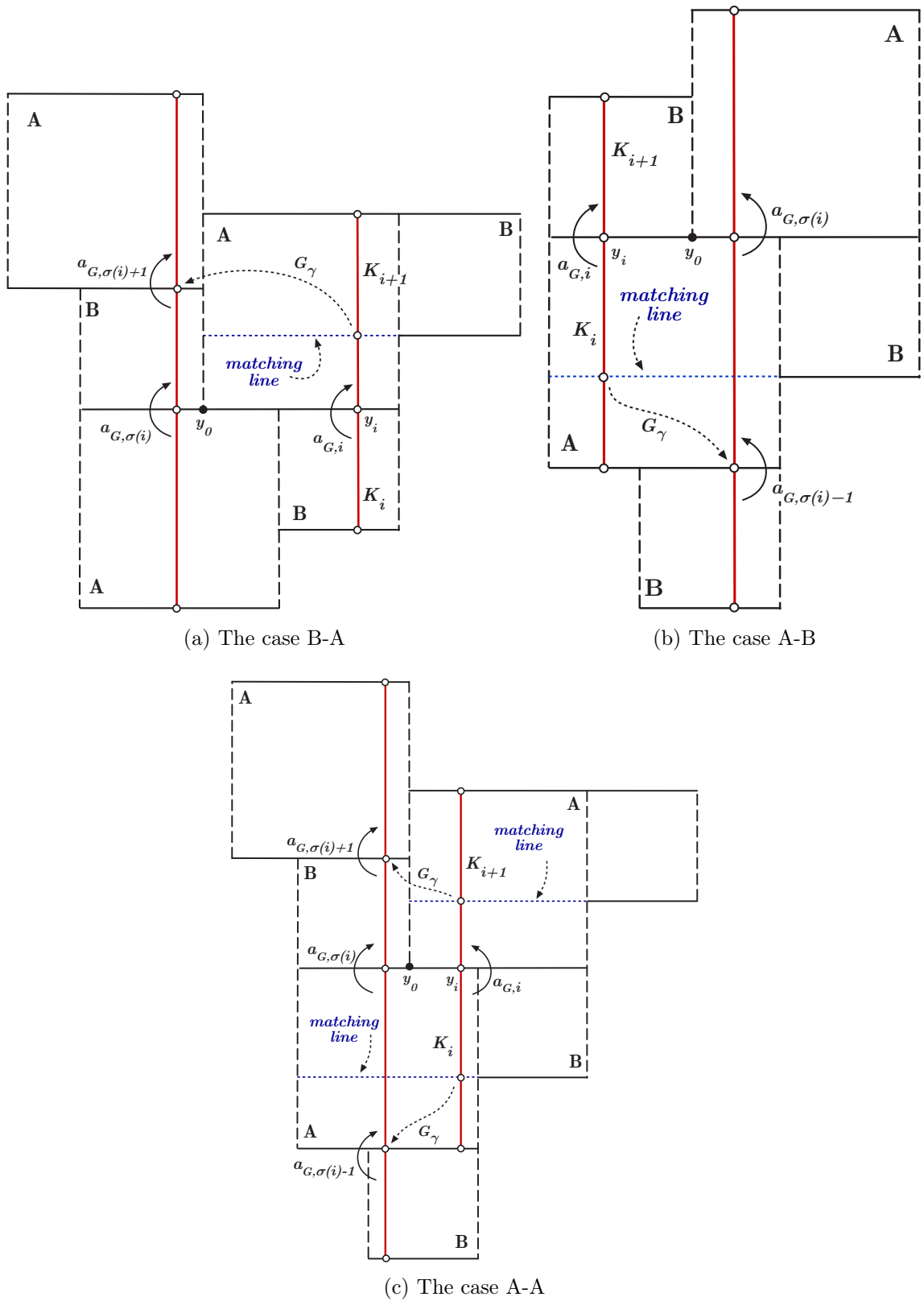

Figure 7.3: The matching condition for the sequence $(a_{G,i})_{i \in \mathbb{N}}$ for the three possible cases when $a = 1$: condition (i) corresponds to $I_{i-1} \in \mathbf{B}$ and $I_i \in \mathbf{A}$; condition (ii) corresponds to $I_{i-1} \in \mathbf{A}$ and $I_i \in \mathbf{B}$; condition (i) corresponds to $I_{i-1} \in \mathbf{A}$ and $I_i \in \mathbf{A}$;

7.4 Boundary condition

A sequence $(a_i)_{i \in \mathbb{N}}$ satisfies the *boundary condition*, if the following limits are well-defined and satisfy the inequalities:

- (i) $\lim_{i \rightarrow +\infty} a_{F_{i+2}}^{-1} (1 + a_{F_{i+1}}^{-1}) \neq 0$
- (ii) $\lim_{i \rightarrow +\infty} a_{F_i} (1 + a_{F_{i+1}}) \neq 0$

Lemma 7.4 *The sequence $(a_{G,i})_{i \in \mathbb{N}}$ satisfies the boundary condition.*

Proof. We observe that $d(K_{F_n}, K_0) = \gamma^n$, $d(K_{F_{2n+1+1}}, I_1) = \gamma^{2n+1}$, $d(K_{F_{2n+1+2}}, I_2) = \gamma^{2n+1}$, $d(K_{F_{2n+1}}, K_1) = \gamma^{2n}$, $d(K_{F_{2n+2}}, K_2) = \gamma^{2n}$ and $d(K_{F_n+3}, K_3) = \gamma^n$ (see Figure 7.4). By continuity of σ_γ , we have that

$$\begin{aligned} \lim_{n \rightarrow \infty} a_{G, F_{2n}} (1 + a_{G, F_{2n+1}}) &= \\ &= \lim_{n \rightarrow \infty} \sigma_G(K_{F_{2n}} : K_{F_{2n+1}}) (1 + \sigma_G(K_{F_{2n+1}} : K_{F_{2n+2}})) \\ &= \sigma_G(K_0 : K_1) (1 + \sigma_G(K_1 : K_2)) \end{aligned}$$

and

$$\begin{aligned} \lim_{n \rightarrow \infty} a_{G, F_{2n+1}} (1 + a_{G, F_{2n+1+1}}) &= \\ &= \lim_{n \rightarrow \infty} \sigma_G(K_{F_{2n+1}} : K_{F_{2n+1+1}}) (1 + \sigma_G(K_{F_{2n+1+1}} : K_{F_{2n+1+2}})) \\ &= \sigma_G(K_0 : I_1) (1 + \sigma_G(I_1 : I_2)). \end{aligned}$$

Hence, by equality (5.6), we obtain that the sequence $(a_{G,i})_{i \in \mathbb{N}}$ satisfies the boundary condition (i). By continuity of σ_G , we have that

$$\begin{aligned} \lim_{n \rightarrow \infty} (a_{G, F_{2n+2}})^{-1} (1 + (a_{G, F_{2n+1}})^{-1}) &= \\ &= \lim_{n \rightarrow \infty} \sigma_G(K_{F_{2n+3}} : K_{F_{2n+2}}) (1 + \sigma_G(K_{F_{2n+2}} : K_{F_{2n+1}})) \\ &= \sigma_G(K_3 : K_2) (1 + \sigma_G(K_2 : K_1)) \end{aligned}$$

and

$$\begin{aligned} \lim_{n \rightarrow \infty} (a_{G, F_{2n+1+2}})^{-1} (1 + (a_{G, F_{2n+1+1}})^{-1}) &= \\ &= \lim_{n \rightarrow \infty} \sigma_G(K_{F_{2n+1+3}} : K_{F_{2n+1+2}}) (1 + \sigma_G(K_{F_{2n+1+2}} : K_{F_{2n+1+1}})) \\ &= \sigma_G(K_3 : I_2) (1 + \sigma_G(I_2 : I_1)). \end{aligned}$$

Hence, by equality (5.7), we obtain that the sequence $(a_{G,i})_{i \in \mathbb{N}}$ satisfies the boundary condition (ii). \square

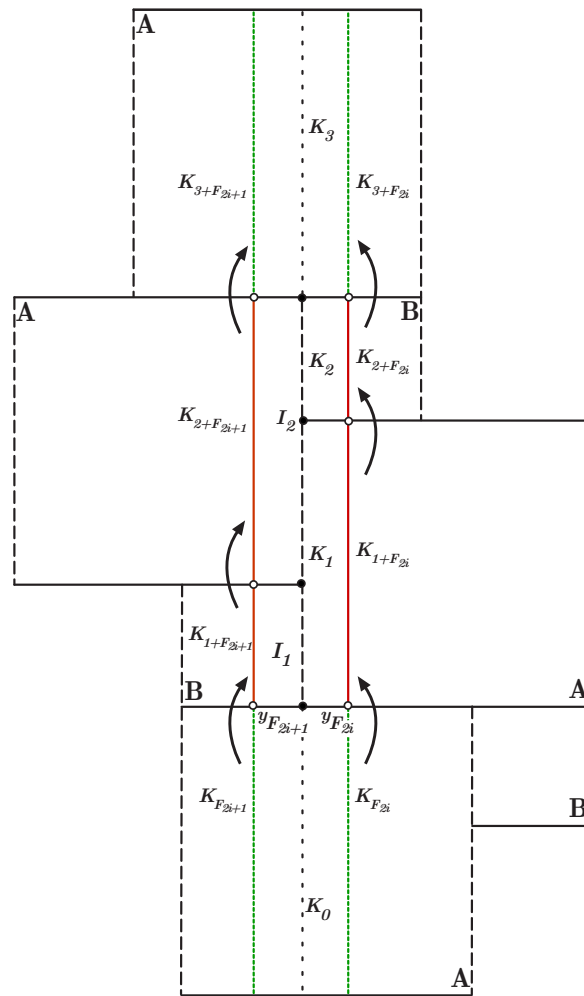

Figure 7.4: A γ -sequence $(a_i)_{i \in \mathbb{L}}$.

7.5 Exponentially fast γ -Fibonacci repetitive property

A sequence $(a_i)_{i \in \mathbb{N}}$ is said to be *exponentially fast γ -Fibonacci repetitive*, if there exist constants $C \geq 0$ and $0 < \mu < 1$ such that

$$|a_{i+F_m} - a_i| \leq C\mu^m,$$

for every $m \geq 5$ and $3 \leq i < F_{m-1}$ and, also, for $i \in \{1, 2\}$ if m is even.

Lemma 7.5 *The sequence $(a_{G,i})$ satisfies the exponentially fast γ -Fibonacci repetitive property.*

Proof. For every $m \geq 5$, we have that either $m = 2n$ or $m = 2n + 1$ for some $n \geq 2$ (see Figure 7.5). Recall that $K_i \cap K_{i+1} = \{y_i\}$, for every $i \in \mathbb{N}_0$.

(i) *Case $m = 2n$.* For $1 \leq i < F_{2n-1}$, the unstable spanning leaf segments K_i , K_{i+1} , $K_{i+F_{2n}}$ and $K_{i+1+F_{2n}}$ belong to $G^{2n}(A)$. Hence, we obtain that

$$d(K_i, K_{i+F_{2n}}) \leq C_0 |y_i - y_{i+F_{2n}}| \leq C_0 \gamma^{2n},$$

for some $C_0 \geq 1$ and $0 < \gamma < 1$. By Hölder continuity of the solenoid function, there exist constants $C \geq 1$ and $\alpha < 1$ such that

$$\begin{aligned} |a_{G,i} - a_{G,i+F_{2n}}| &= |\sigma_G(K_i : K_{i+1}) - \sigma_G(K_{i+F_{2n}} : K_{i+1+F_{2n}})| \\ &< C (\gamma^{2n})^\alpha \\ &= C (\gamma^\alpha)^{2n}. \end{aligned}$$

(ii) *Case $m = 2n + 1$.* For $3 \leq i < F_{2n}$, the unstable spanning leaf segments K_i , K_{i+1} , $K_{i+F_{2n+1}}$ and $K_{i+1+F_{2n+1}}$ belong to $G^{2n}(B)$. Hence, we obtain that

$$d(K_i, K_{i+F_{2n+1}}) \leq C_0 |y_i - y_{i+F_{2n+1}}| \leq C_0 \gamma^{2n+1},$$

for some $C_0 \geq 1$ and $0 < \gamma < 1$. By Hölder continuity of the solenoid function, there exist constants $C \geq 1$ and $\alpha < 1$ such that

$$\begin{aligned} |a_{G,i} - a_{G,i+F_{2n+1}}| &= |\sigma_G(K_i : K_{i+1}) - \sigma_G(K_{i+F_{2n+1}} : K_{i+1+F_{2n+1}})| \\ &< C (\gamma^{2n+1})^\alpha \\ &= C \gamma^\alpha (\gamma^\alpha)^{2n}. \end{aligned}$$

Hence, the sequence $(a_{G,i})$ satisfies the exponentially fast γ -Fibonacci repetitive property with $\mu = \gamma^\alpha$. \square

7.6 γ -Tilings

A *tiling* $\mathcal{T} = \{I_i \subset \mathbb{R} : i \in \mathbb{N}\}$ of the positive real line is a collection of intervals I_i , with the following properties:

- (i) the intervals are closed;
- (ii) any two distinct intervals have disjoint interiors;

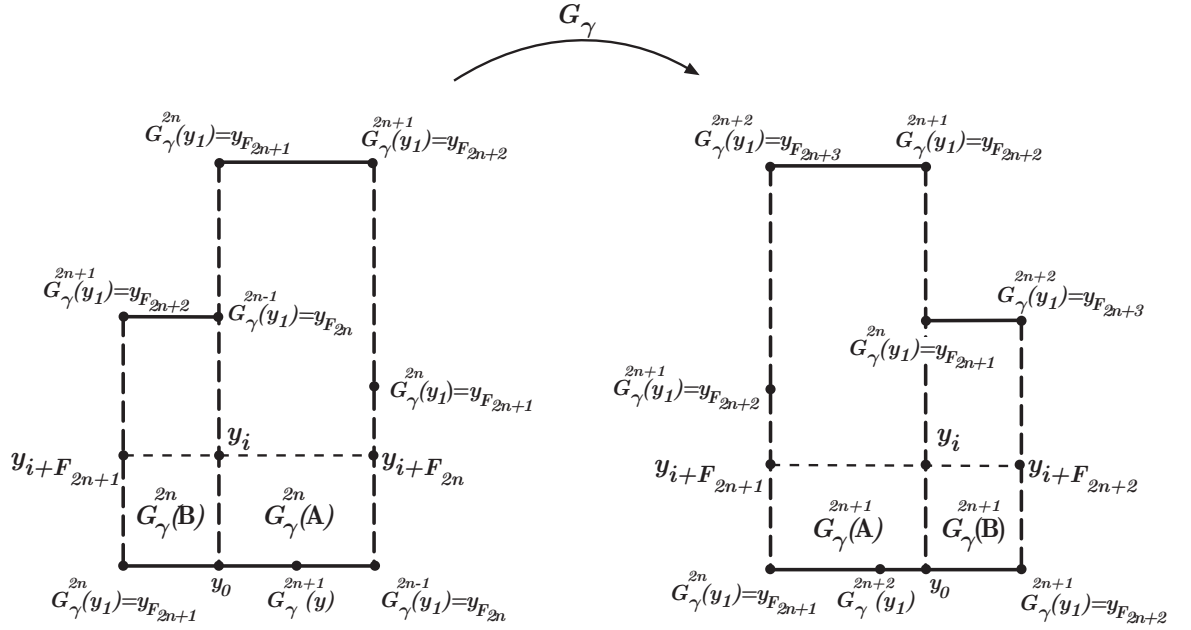

Figure 7.5: The exponentially fast γ -Fibonacci repetitive condition.

- (iii) the union $\cup_{i \in \mathbb{N}} I_i$ is equal to the positive real line;
- (iv) for every $i \in \mathbb{N}$ the intersection of the intervals I_i and I_{i+1} is only a point, which is an endpoint, simultaneously, of both intervals.

We say that two tilings $\mathcal{T}_1 = \{I_i \subset \mathbb{R} : i \in \mathbb{N}\}$ and $\mathcal{T}_2 = \{J_i \subset \mathbb{R} : i \in \mathbb{N}\}$ of the positive real line are in the same affine class, if there exists an affine map $h : \mathbb{R} \rightarrow \mathbb{R}$ such that $h(I_i) = J_i$, for every $i \in \mathbb{N}$. Thus, every positive sequence $(a_i)_{i \in \mathbb{N}}$ determines a unique affine class of tilings $\mathcal{T} = \{I_i \subset \mathbb{R} : i \in \mathbb{N}\}$, such that $a_i = |I_{i+1}| / |I_i|$, and vice-versa.

Definition 7.2 A γ -sequence $(a_i)_{i \in \mathbb{N}}$ is an exponentially fast γ -Fibonacci repetitive sequence that satisfies the matching and the boundary conditions. A tiling $\mathcal{T} = \{I_i \subset \mathbb{R} : i \in \mathbb{N}\}$ of the positive real line is a γ -tiling if the corresponding sequence $(a_i = |I_{i+1}| / |I_i|)_{i \in \mathbb{N}}$ is a γ -sequence.

We say that a γ -tiling \mathcal{T}_γ is *rigid* if its associated γ -sequence is rigid (see Definition 7.1).

Putting together Definition 7.2, and Lemmas 7.3, 7.4 and 7.5 we have that the sequence $(a_{G,i})$ is a γ -sequence.

7.7 Proof of Theorem 7.1

By Lemma 7.1, the map $G \rightarrow (a_{G,i})_{i \in \mathbb{N}}$ determines a correspondence between Anosov diffeomorphisms G in \mathcal{G} and γ -sequences such that $a_{G,i} = \sigma_G(K_i : K_{i+1})$. Putting together Lemma 7.3, Lemma 7.4 and Lemma 7.5, we get that $(a_{G,i})_{i \in \mathbb{N}}$ is a γ -sequence. By Corollary 6.3, any two C^{1+} Anosov diffeomorphisms, G_1 and G_2 , that are C^{1+} smooth conjugate determine the same solenoid functions $\sigma_{G_1} = \sigma_{G_2}$. Hence, by Lemma 7.1, $(a_{G_1,i})_{i \in \mathbb{N}} = (a_{G_2,i})_{i \in \mathbb{N}}$.

Conversely, given a γ -sequence $(a_i)_{i \in \mathbb{N}}$ we construct a solenoid function σ_γ in \mathbf{sol} as follows. Recall that $\mathbb{L} = \{(K_i : K_{i+1}), i \in \mathbb{N}\}$ is a dense set in \mathbf{sol} . We define $\sigma_\gamma(K_i : K_{i+1}) = a_i$, for every $(K_i : K_{i+1}) \in \mathbb{L}$. Since the sequence $(a_i)_{i \in \mathbb{N}}$ is exponentially fast Fibonacci repetitive, similarly to the proof of Lemma 7.5, we get that $\sigma_\gamma|_{\mathbb{L}}$ is Hölder continuous. Hence, using that \mathbb{L} is dense in \mathbf{sol} , we define σ_γ in \mathbf{sol} as the unique Hölder continuous extension of $\sigma_\gamma|_{\mathbb{L}}$ to \mathbf{sol} . Now, it is enough to check that the Hölder continuous function σ_γ in \mathbf{sol} satisfies the matching and the boundary condition. Since $(a_i)_{i \in \mathbb{N}}$ satisfies the γ -matching condition, similarly to the proof of Lemma 7.3, we have that $\sigma_\gamma|_{\mathbb{L}}$ satisfies the matching condition in \mathbb{L} . Hence, using that σ_γ in \mathbf{sol} is a continuous function, we get that the σ_γ in \mathbf{sol} , also, satisfies the matching condition. Recall, from the introduction of this chapter, the definition of K_0 , K_1 , K_2 and K_3 . Recall that the spanning leaf segments I_1 and I_2 are, respectively, the right boundaries of the Markov rectangles B and A , as in Section 5.3. We observe that $d(K_{F_n}, K_0) = \gamma^n$, $d(K_{F_{2n+1}+1}, I_1) = \gamma^{2n+1}$, $d(K_{F_{2n+1}+2}, I_2) = \gamma^{2n+1}$, $d(K_{F_{2n+1}}, K_1) = \gamma^{2n}$, $d(K_{F_{2n+2}}, K_2) = \gamma^{2n}$ and $d(K_{F_n+3}, K_3) = \gamma^n$. By continuity of σ_γ , we have that

$$\begin{aligned} \sigma_\gamma(K_0 : K_1)(1 + \sigma_\gamma(K_1 : K_2)) &= \\ &= \lim_{n \rightarrow \infty} \sigma_\gamma(K_{F_{2n}} : K_{F_{2n+1}})(1 + \sigma_\gamma(K_{F_{2n+1}} : K_{F_{2n+2}})) \\ &= \lim_{n \rightarrow \infty} a_{F_{2n}}(1 + a_{F_{2n+1}}) \end{aligned}$$

and

$$\begin{aligned} \sigma_\gamma(K_0 : I_1)(1 + \sigma_\gamma(I_1 : I_2)) &= \\ &= \lim_{n \rightarrow \infty} \sigma_\gamma(K_{F_{2n+1}} : K_{F_{2n+1}+1})(1 + \sigma_\gamma(K_{F_{2n+1}+1} : K_{F_{2n+1}+2})) \\ &= \lim_{n \rightarrow \infty} a_{F_{2n+1}}(1 + a_{F_{2n+1}+1}). \end{aligned}$$

Hence, by the boundary condition (i) of the γ -sequence $(a_i)_{i \in \mathbb{N}}$, we obtain that σ_γ

satisfies equality (5.6). By continuity of σ_γ , we have that

$$\begin{aligned} & \sigma_\gamma(K_3 : K_2)(1 + \sigma_\gamma(K_2 : K_1)) \\ &= \lim_{n \rightarrow \infty} \sigma_\gamma(K_{F_{2n+3}} : K_{F_{2n+2}})(1 + \sigma_\gamma(K_{F_{2n+2}} : K_{F_{2n+1}})) \\ &= \lim_{n \rightarrow \infty} a_{F_{2n+2}}^{-1}(1 + a_{F_{2n+1}}^{-1}) \end{aligned}$$

and

$$\begin{aligned} & \sigma_\gamma(K_3 : I_2)(1 + \sigma_\gamma(I_2 : I_1)) = \\ &= \lim_{n \rightarrow \infty} \sigma_\gamma(K_{F_{2n+1+3}} : K_{F_{2n+1+2}})(1 + \sigma_\gamma(K_{F_{2n+1+2}} : K_{F_{2n+1+1}})) \\ &= \lim_{n \rightarrow \infty} a_{F_{2n+1+2}}^{-1}(1 + a_{F_{2n+1+1}}^{-1}). \end{aligned}$$

Hence, by the boundary condition (ii) of the γ -sequence $(a_i)_{i \in \mathbb{N}}$, we obtain that σ_γ satisfies equality (5.7). Therefore, σ_γ is a solenoid function. \square

7.8 Complete set of holonomies

Let $\mathcal{M}_\gamma = \{A, B\}$ be a Markov partition of the Anosov automorphism G_γ . Recall the topological conjugacy $h = h_G : \mathbb{T} \rightarrow \mathbb{T}$ between G_γ and the C^1+ Anosov diffeomorphism G . Let $\mathcal{M}_G = \{h(A), h(B)\}$ be a Markov partition of G . Suppose that M and N are Markov rectangles, and $x \in \text{int}(M)$ and $y \in \text{int}(N)$. We say that x and y are *stable holonomically related*, if (i) there is an stable leaf segment $\ell^u(x, y)$ such that $\partial \ell^u(x, y) = \{x, y\}$, and (ii) $\ell^u(x, y) \subset \ell^u(x, M) \cup \ell^u(y, N)$. Let $P = P_{\mathcal{M}}$ be the set of all pairs (M, N) such that there are points $x \in \text{int}(M)$ and $y \in \text{int}(N)$ unstable holonomically related.

For every Markov rectangle $M \in \mathcal{M}_G$, choose an unstable spanning leaf segment $\ell(x, M)$ in M for some $x \in M$. Let $\mathcal{I} = \{\ell_M : M \in \mathcal{M}\}$. For every pair $(M, N) \in P$, there are maximal leaf segments $\ell_{(M,N)}^D \subset \ell_M$, $\ell_{(M,N)}^C \subset \ell_N$ such that the unstable holonomy $h_{(M,N)} : \ell_{(M,N)}^D \rightarrow \ell_{(M,N)}^C$ is well-defined. We call such holonomies $h_{(M,N)} : \ell_{(M,N)}^D \rightarrow \ell_{(M,N)}^C$ the *unstable primitive holonomies* associated to the Markov partition \mathcal{M}_G . The *complete set of unstable holonomies* \mathcal{H}_G consists of all stable primitive holonomies and their inverses. In Figure 7.6, we exhibit the complete set of unstable holonomies

$$\mathcal{H}_G = \left\{ h_{(A,A)}, h_{(A,A)}^{-1}, h_{(A,B)}, h_{(A,B)}^{-1}, h_{(B,A)}, h_{(B,A)}^{-1} \right\}$$

associated to the Markov partition \mathcal{M}_G .

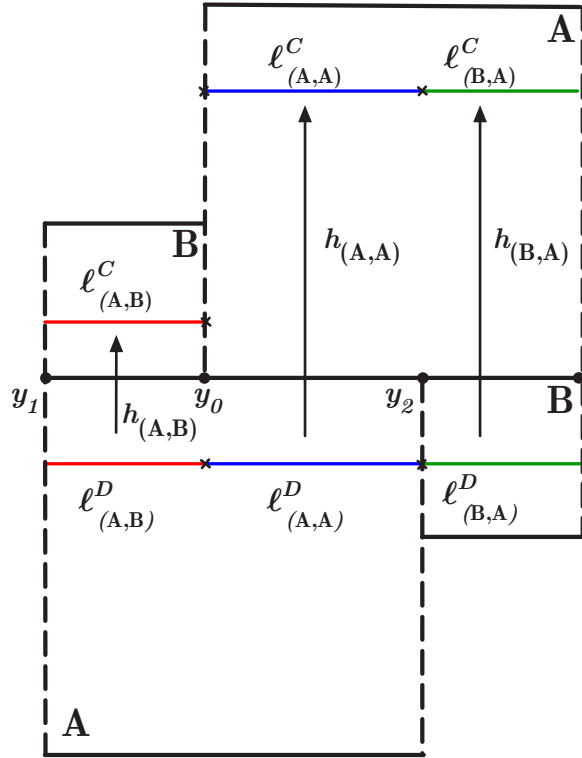

Figure 7.6: A complete set of unstable holonomies \mathcal{H}_G associated to the Markov partition \mathcal{M}_G .

A diffeomorphism $\theta : I \rightarrow J$ is said to be $C^{1+\text{zygmund}}$, if θ is C^1 and the derivative θ' satisfies the zygmond condition, i.e. for all points $x, y \in I$,

$$\left| \theta'(x) + \theta'(y) - 2\theta' \left(\frac{x+y}{2} \right) \right| = \chi_\theta (|y-x|),$$

where the function χ_θ is such that $\chi_\theta(t) \rightarrow 0$ when $t \rightarrow 0$. In particular, a $C^{2+\beta}$ diffeomorphism, with $\beta > 0$, is a $C^{1+\text{zygmund}}$ diffeomorphism. The importance of this smooth class follows from the fact that it corresponds to maps that distort cross-ratios of quadruples of points in I by an amount that is $o(|I|)$ (see [21] and [37]).

A *unstable lamination atlas* $\mathcal{L} = \mathcal{L}^u(G, \rho)$, determined by a Riemannian metric ρ , is the set of all maps $e : I \rightarrow \mathbb{R}$, where e is an isometry between the induced Riemannian metric on the unstable leaf segment I and the Euclidean metric on the reals. By Theorem 2.1 in [30], the basic unstable and stable holonomies are C^{1+} with respect to the lamination atlas \mathcal{L} .

Definition 7.3 A complete set of unstable holonomies \mathcal{H}_G is $C^{1+\text{zygmund}}$ if all the holonomies in \mathcal{H}_G are $C^{1+\text{zygmund}}$ with respect to the atlas $\mathcal{L}^s(G, \rho)$.

7.9 Proof of Theorem 7.2

By Lemma 7.3 and Theorem 1 in [29], if G has a $C^{1+\text{zygmund}}$ complete system of unstable holonomies then $\sigma_G = \sigma_\gamma$. By Lemma 7.2, for $i \in \mathbb{N}$ with γ -Fibonacci decomposition $(a_{n_0}F_{n_0}, \dots, a_{n_p}F_{n_p})$, we have that the following conditions hold:

- (i) If either $(n_p = 1, a_p = 1$ and n_{p-1} is odd) or $(n_p = 1, a_p = 2$ and n_{p-1} is even), then $K_i \in B$ and $K_{i+1} \in A$. Hence, $a_i = \sigma_\gamma(K_i : K_{i+1}) = \gamma^{-1}$.
- (ii) If either $(n_p = 1, a_p = 1$ and n_{p-1} is even) or $(n_p \geq 2$ and n_p is odd), then $K_i \in A$ and $K_{i+1} \in B$. Hence, $a_i = \sigma_\gamma(K_i : K_{i+1}) = \gamma$.
- (iii) If either $(n_p = 1, a_p = 2$ and n_{p-1} is odd) or $(n_p \geq 2$ and n_p is even), then $K_i, K_{i+1} \in A$. Hence, $a_i = \sigma_\gamma(K_i : K_{i+1}) = 1$.

Thus, from conditions (i), (ii) and (iii), we conclude that $(a_{\gamma,i})_{i \in \mathbb{N}}$ is the rigid γ -sequence. \square

References

- [1] Almeida, J. P.: Pinto's rigid tilings, (*to be submitted*).
- [2] Almeida, J. P.: Pinto's golden tilings, in "Discrete Dynamics and Difference Equations" (eds. Saber Elaydi, H. Oliveira, J. M. Ferreira and João F. Alves), Proceedings of the Twelfth International Conference on Difference Equations and Applications, World Scientific Publishing, (2010) 147–154.
- [3] Almeida, J. P., Fisher, A. M., Pinto, A. A. and Rand, D. A.: Anosov diffeomorphisms,(2012) 1–9 (*submitted*).
- [4] Almeida, J. P., Fisher, A. M., Pinto, A. A. and Rand, D. A.: Anosov and circle diffeomorphisms, in "Dynamics Games and Science I" (eds. M. Peixoto, A. Pinto and D. Rand), Springer Proceedings in Mathematics, Springer Verlag, (2011) 11–23.
- [5] Almeida, J. P., Pinto, A. A. and Rand, D. A.: Renormalization of circle diffeomorphism sequences and Markov sequences, (2012) 1–8 (*submitted*).
- [6] Arnol'd, V. I.: Small denominators I: on the mapping of a circle into itself. *Investijia Akad. Nauk. Math.*, 25, 1, (1961), 21-96. Transl. A.M.S., 2nd series, 46, 213-284.
- [7] Cawley, E.: The Teichmüller space of an Anosov diffeomorphism of T^2 . *Inventiones Mathematicae*, **112**, (1993), 351–376.
- [8] Couillet, P. and Tresser, C.: Itération d'endomorphismes et groupe de renormalisation. *J. de Physique*, C5 25 (1978).
- [9] Franks, J.: Anosov diffeomorphisms. In: Smale, S. (ed.) *Global Analysis*. **14** AMS Providence RI (1970), 61–93.

- [10] Ghys, E.: Rigidity différentiable des groupes Fuchsien. Publ. IHES **78** (1993), 163–185.
- [11] Herman, M. R.: Sur la conjugaison différentiable des difféomorphismes du cercle à des rotations. Publ. IHES **49** (1979), 5–233.
- [12] Jiang, Y., Teichmüller structures and dual geometric Gibbs type measure theory for continuous potentials, *preprint* (2008), 1–67.
- [13] Jiang, Y., Metric invariants in dynamical systems. Journal of Dynamics and Differentiable Equations, **17**(1) (2005), 51–71 .
- [14] Lanford, O.: Renormalization group methods for critical circle mappings with general rotation number. VIIIth International Congress on Mathematical Physics. World Sci. Publishing, Singapore (1987), 532–536.
- [15] de la Llave, R.: Invariants for Smooth conjugacy of hyperbolic dynamical systems II. Commun. Math. Phys., **109**(3) (1987), 369–378.
- [16] Manning, A.: There are no new Anosov diffeomorphisms on tori. Amer. J. Math., **96** (1974), 422.
- [17] Mané R., *Ergodic Theory and Differentiable Dynamics*. Springer-Verlag, Berlin 1987.
- [18] Marco, J.M., Moriyo, R.: Invariants for Smooth conjugacy of hyperbolic dynamical systems I. Commun. Math. Phys., **109** (1987), 681–689.
- [19] Marco, J.M., Moriyo, R.: Invariants for Smooth conjugacy of hyperbolic dynamical systems III. Commun. Math. Phys., **112** (1987), 317–333.
- [20] Masur, H.: Interval exchange transformations and measured foliations. The Annals of Mathematics. 2nd Ser., **115**(1) (1982), 169–200.
- [21] de Melo, W., van Strien, S.: One-dimensional Dynamics. A series of Modern Surveys in Mathematics. Springer-Verlag, New York (1993).
- [22] Penner, R. C. and Harer, J. L.: *Combinatorics of Train-Tracks*. Princeton University Press, Princeton, New Jersey (1992).
- [23] Pinto, A. A., Almeida J. P., Fisher, A. M. and Portela, A.: Anosov diffeomorphism sequences and tiling sequences, (*to be submitted*).

- [24] Pinto, A. A., Almeida, J. P., and Portela, A.: Anosov diffeomorphisms and γ -tilings, (*to be submitted*).
- [25] Pinto, A. A., Almeida, J. P. and Portela, A.: Golden tilings. Transactions of the American Mathematical Society, **364** (2012), 2261–2280.
- [26] Pinto, A. A., Almeida, J. P. and Rand, D. A.: Anosov and renormalized circle diffeomorphisms, (*to be submitted*).
- [27] Pinto, A. A. and Rand, D. A.: Train-tracks with C^{1+} self-renormalisable structures. Journal of Difference Equations and Applications, **16**(8) (2010), 945–962.
- [28] Pinto, A. A. and Rand, D. A.: Solenoid functions for hyperbolic sets on surfaces. Dynamics, Ergodic Theory and Geometry, (ed. Boris Hasselblat), MSRI Publications, **54** (2007), 145–178 .
- [29] Pinto, A. A. and Rand, D. A.: Rigidity of hyperbolic sets on surfaces. J. London Math. Soc., **71**(2) (2004), 481–502.
- [30] Pinto, A. A. and Rand, D. A.: Smoothness of holonomies for codimension 1 hyperbolic dynamics. Bull. London Math. Soc., **34** (2002), 341-352.
- [31] Pinto, A. A. and Rand, D. A.: Teichmüller spaces and HR structures for hyperbolic surface dynamics. Ergod. Th. Dynam. Sys, **22** (2002), 1905–1931.
- [32] Pinto, A. A. and Rand, D. A.: Existence, uniqueness and ratio decomposition for Gibbs states via duality. Ergod. Th. & Dynam. Sys., **21** (2001) 533–543.
- [33] Pinto, A. A. and Rand, D. A.: Characterising rigidity and flexibility of pseudo-Anosov and other transversally laminated dynamical systems on surfaces. Warwick Preprint 1995.
- [34] Pinto, A. A., Rand, D. A. and Ferreira, F.: Arc exchange systems and renormalization. Journal of Difference Equations and Applications **16**(4) (2010), 347-371.
- [35] Pinto, A. A., Rand, D. A. and Ferreira, F.: Cantor exchange systems and renormalization. Journal of Differential Equations, **243** (2007), 593–616.
- [36] Pinto, A. A., Rand, D. A. and Ferreira, F.: *Fine structures of hyperbolic diffeomorphisms*. Springer Monographs in Mathematics, Springer (2010).

- [37] Pinto, A. A. and Sullivan, D.: The circle and the solenoid. Dedicated to Anatole Katok On the Occasion of his 60th Birthday. *DCDS A*, **16**(2) (2006), 463–504.
- [38] Schub, M.: *Global Stability of Dynamical Systems*. Springer-Verlag, (1987).
- [39] Sinai, Ya, Markov Partitions and C-diffeomorphisms. *Anal. and Appl.* **2** (1968), 70–80.
- [40] Veech, W.: Gauss measures for transformations on the space of interval exchange maps. *The Annals of Mathematics*, 2nd Ser. **115**(2) (1982), 201–242.
- [41] Williams, R. F.: Expanding attractors. *Publ. I.H.E.S.*, **43** (1974), 169–203.
- [42] Yoccoz J. C.: Conjugaison différentiable des difféomorphismes du cercle dont le nombre de rotation vérifie une condition diophantienne. *Ann. Scient. Éc. Norm. Sup.*, 4 série, t, **17** (1984), 333–359.