

Big Data and Analytics: The case study of students mobility

Dmitrii Mukhin

*Dissertação/Trabalho de Projeto/ Relatório Final de Estágio Profissional
apresentad(a) à Escola Superior de Tecnologia e Gestão para obtenção do Grau
de Mestre em Informática*

Trabalho realizado sob a orientação de:
Professor João Paulo Pereira
Professor Savinskaya Dina Nikolaevna

Bragança
October 2021

Abstract

It's no secret that the most important thing in our world is information. Nowadays, almost every action leaves a trace. And if we use this data correctly, we will get new knowledge and predictions. But this requires new specialized technologies such as Big Data.

The work described in this dissertation focuses on three methods of Big Data analysis: descriptive analysis, correlation and predictive analysis.

The purpose of the work is to explore these methods for practical application to a dataset containing information about IPB and Erasmus students.

The following tasks were performed: collecting data from international students about their university practices and mobility, conducting descriptive analysis on general characteristics by year, course, gender, place of residence, degree, number of subjects studied and their grade point average.

Correlation heat charts were constructed between the values in the dataset and dependencies were analyzed.

The most important contribution of this paper is the practical application of three machine learning algorithms (Linear regression, Ridge regression, and Random forest) to predict the number of Erasmus students for the next year. The machine learning algorithms build a model from sample data, known as "training data," to make predictions or decisions without being explicitly programmed to do so.

Keywords: big data, machine learning, descriptive analysis, graph, table, correlation, predictive analysis, linear regression, comb regression, random forest.

Foreword

I would like to express my deep gratitude to the Polytechnic Institute of Bragança (IPB) and the professors for the education and support. During the training, I received a lot of new knowledge and experience in the field of Information Systems, which, of course, will help me in my future professional activities.

Thank you!

Table of contents

Abstract.....	3
Table of contents.....	5
List of Figures	8
List of Abbreviations	10
1. Introduction.....	11
1.1 Context and motivation	11
1.2 Main objectives	12
1.3 Structure of the work.....	14
2. Big data	15
2.1 Definition of Big data technologies	15
2.2 History of Big Data	17
2.3 Types of Big Data	18
2.3.1 Structured.....	18
2.3.2 Unstructured.....	19
2.3.3 Semi-structured.....	20
2.4 Characteristics of Big Data	20
2.5 How big data works.....	22
2.6 Technologies and trends of working with Big Data.....	23
2.7 Big Data Analysis Methods and Techniques	25
2.8 Big Data in industry	27
3. Data Mining	29
3.1 Definition	29
3.2 Classes of Data Mining Systems.....	29
3.2.1 Object-oriented analytical systems	30
3.2.2 Statistical packages	30
3.2.3 Neural networks	31
3.2.4 Systems of reasoning based on similar cases.....	31
3.2.5 Decision trees.....	32
3.2.6 Evolutionary Programming.....	32
3.2.7 Genetic algorithms	33
3.2.8 Constrained search algorithms.....	34
3.2.9 Systems for visualizing multidimensional data	35

3.3	Results.....	35
4.	Data transfer, analysis and processing	37
4.1	Definition	37
4.2	Data Analysis Tools.....	37
4.3	Types of Data Analysis: Techniques and Methods	38
4.4	Correlation	39
4.4.1	Determining correlation	39
4.4.2	Correlation Matrices	39
4.5	Machine learning algorithms for data processing.....	41
4.5.1	Linear regression	42
4.5.2	Logistic regression	43
4.5.3	Linear Discriminant Analysis (LDA).....	44
4.5.4	Decision trees	45
4.5.5	Naive Bayesian classifier	48
4.5.6	K-nearest neighbors.....	48
4.5.7	Learning vector quantization (LVQ).....	49
4.5.8	Support-vector machine (SVM)	50
4.5.9	Boosting and AdaBoost.....	51
5.	Case study.....	53
5.1	Description.....	53
5.2	Descriptive analyze.....	54
5.2.1	IPB.....	54
5.2.2	Mobility	72
5.3	Correlation diagrams.....	75
5.3.1	Part of the Student Characteristics	76
5.3.2	Part of the Mobility	81
5.4	Predictive analyze	82
5.4.1	Linear Regression.....	84
5.4.2	Ridge Regression.....	86
5.4.3	Random Forest	88
5.5	Results.....	92
6.	Conclusions and Future works	95
7.	References	105
8.	Annexes	107
8.1	Graphics.....	107

8.2 Tables	217
------------------	-----

List of Figures

Figure 2.1: Growth of Big Data by 2020, IDC Digital Universe forecast from 2012	16
Figure 2.2: Types of Big Data.....	18
Figure 2.3: Example of Structured Data (An ‘Employee’ table in a database is an example of Structured Data)[20].....	19
Figure 2.4: Example of Unstructured Data (The output returned by ‘Google Search’)	20
Figure 2.5: Example of Unstructured Data (Personal data stored in an XML file)[20].....	20
Figure 2.6: 5 V’s of Big Data.....	22
Figure 2.7: Map Reduce	25
Figure 3.1: Data Mining is a multidisciplinary field.....	30
Figure 4.1: Data Analysis Tools[28].....	37
Figure 5.25: Types of correlations	41
Figure 4.2: Linear regression[25].....	42
Figure 4.3: Logistic function[25]	44
Figure 4.4: Linear Discriminant Analysis[25]	45
Figure 4.5: Decision trees[25].....	46
Figure 4.6: Naive Bayesian classifier[25]	48
Figure 4.7: K-nearest neighbors[25]	49
Figure 4.8: Learning vector quantization[25]	49
Figure 4.9: Bagging and the Random Forest[25].....	50
Figure 4.10: Boosting and AdaBoost[25]	51
Figure 5.1: General characterization by Year (School)	55
Figure 5.2: General characterization by Year (Course), ESA.....	60
Figure 5.3: General characterization by Year (Course), EsACT	60
Figure 5.4: General characterization by Year (Course), ESE	61
Figure 5.5: General characterization by Year (Course), ESSa.....	61
Figure 5.6: General characterization by Year (Course), ESTiG	62
Figure 5.7: General characterization by Year (Gender).....	63
Figure 5.8: General characterization by Year (Age).....	64
Figure 5.9: General characterization by Year (Distrito)	65
Figure 5.10: General characterization by Year (Concelho), Braganca	65
Figure 5.11: General characterization by Year (Concelho), Lisboa	66
Figure 5.12: General characterization by Year (Concelho), Porto.....	66
Figure 5.13: General characterization by Year (Concelho), Vila Real	67
Figure 5.14: General characterization by Year (Degree)	68
Figure 5.15: General characterization by Year (Type Entry)	68
Figure 5.16: General characterization by Year (Nationality).....	69
Figure 5.17: General characterization by Year (Average of the not credit subjects).....	70
Figure 5.18: General characterization by Year (Average of the credited subjects)	70
Figure 5.19: General characterization by Year (Total subjects credited)	71
Figure 5.20: General characterization by Year (Sum of the subjects credited)	72
Figure 5.21: General characterization by Year (Final average).....	72
Figure 5.22: General characterization by IPB Course Units (Year)	73
Figure 5.23: General characterization by Country in Mobility(Total).....	74
Figure 5.24: General characterization by Country in Mobility(Total).....	75
Figure 5.26: Full Correlation of “Student Characters” dataset.	77
Figure 5.27: Correlation of “Student Characters” dataset.....	79

Figure 5.28: Correlation of “Student Characters” dataset.	80
Figure 5.29: Correlation of “Student Characters” dataset.	81
Figure 5.30: Full Correlation of “Creditation” dataset.	82
Figure 5.34: Up-to-date information on students who have taken a unit course in IPB mobility	83
Figure 5.35: Up-to-date information on students who have taken a unit course in IPB mobility	84
Figure 5.36: Result of Linear Regression.....	86
Figure 5.37: Result of Ridge Regression.....	88
Figure 5.38: Result of Random Forest	90
Figure 5.39: Result of Random Forest for prediction 2020/2021 years	91

List of Abbreviations

IPB – Instituto Politécnico de Bragança

XML – Extensible Markup Language

IDC – International Data Corporation

DBMS – Database Management System

CSV – Comma-Separated Values

ETL – Extract, Transform, Load

SAP – System Applications

RAM – Computer Random Access Memory

URL – Uniform Resource Locator

MSE – Mean Squared Error

LDA – Linear Discriminant Analysis

KNN – K Nearest Neighbor

LVQ – Learning Vector Quantization

SVM – Support Vector Machine

CTeSP – Cursos Técnicos Superiores Profissionais

SPSS – Statistical Package for the Social Sciences

OWL – Web Ontology Language

ESE – Escola Superior de Educação de Bragança

ESTiG – Escola Superior de Tecnologia e Gestão de Bragança

EsACT – Escola Superior de Comunicação, Administração e Turismo de Mirandela

ECTS – European Credit Transfer and Accumulation System

1. Introduction

1.1 Context and motivation

Data Science is an activity related to analyzing data and finding better solutions based on it. Previously, such tasks were handled by specialists in mathematics and statistics. Then artificial intelligence came to the rescue, making it possible to incorporate optimization and computer science into the analysis methods. This new approach proved to be much more effective.

How does the process work? It all starts with collecting large amounts of structured and unstructured data and converting it into a digestible format. Then we use visualization, statistics and analytical methods - machine learning, probabilistic analysis and predictive models, neural networks and their application to solve urgent problems.

The Python programming language has recently been increasingly used for data analysis, both in science and in the commercial sphere. This is facilitated by the simplicity of the language, as well as a large variety of open source libraries. In my thesis, I explore and classify a data set using some Python libraries.

At the core of the field is making sense of data sets, visualizing, gathering ideas, and making decisions based on that data. Data analysts use some machine learning and Big Data techniques: cloud computing, tools for creating a virtual development environment, and more.

For the study, a dataset was collected on information from international students on their academic and research practices at the university and mobility. Dataset for machine learning is processed and structured information in tabular form.

My goal is to find out which conditions influence which factors, as well as to determine and analyze the dependencies of the values on each other. In order to further display the results of my research data dependencies visually in the form of graphs and tables for clarity. Namely, to create barplots for descriptive analysis, create correlation charts and display the correlation index for each variable dependency, as well as to apply machine learning algorithms to the current dataset, analyze, present in graphs and record the results of each algorithm to subsequently select the best one among them.

I anticipate that the results of my dissertation will be research in data analysis and machine learning for my dataset. My goal is to find out the relationships between external and internal factors that determine student characteristics, namely what factors influence the age of incoming students, country of origin, course choices, their grades, and more.

1.2 Main objectives

The purpose of the thesis is to analyze a dataset containing various kinds of information about students carrying out their activities inside and outside the university in mobility. In accordance with the set aim the following tasks of the thesis:

- 1) To study Big data and Data mining technologies for this study.
- 2) Explore the principles of descriptive analysis, predictive analysis, and correlation to conduct analysis on student data in mobility and IPB.
- 3) Make a descriptive analysis on the overall characteristic by year of enrollment of the student, by school of study, by chosen school and course for the major factors: school, course, gender, age, Concelho, Distrito, degree, type entry, average of the not credit subjects, average of the credited subjects, total subjects credited, sum of the subjects credited (sum ECTS) and final average.
- 4) Analyze research results for university students and students in mobility.
- 5) Construct correlation diagrams for a given set of data, analyze them and draw conclusions.
- 6) To study machine learning algorithms and choose the most appropriate one to predict the number of students for the following year in mobility by unit course from IPB.
- 7) Analyze the results of predicting the selected machine learning algorithm for the next year and draw conclusions.

1.3 Method

Purpose and objectives of the work: The purpose of the master's thesis is the general analysis of student data of three types: descriptive analysis, correlation analysis and predictive analysis. In order to achieve the formulated goal, the following research objectives are addressed in the work:

- 1) Creating a dataset with general information about students in the university and mobility in the format ".xlsx".
- 2) Preparation of the dataset for analysis: replacing the same values, eliminating empty cells.
- 3) Selection of general characteristics for descriptive analysis: General characterization by Year, General characterization by School, General characterization by Course, General characterization by Age, General characterization by Concelho&Distrito, General characterization by Degree, General characterization by Type Entry, General characterization by Average of the non-credit subjects, General characterization by Average of the credited subjects, General characterization by Total subjects credited, General characterization by Sum of the subjects credited, General characterization by Final Average. Analysis of Descriptive Charts.
- 4) Creation of thermal correlation charts. Finding dependencies of values and making hypotheses followed by analysis.
- 5) Selecting machine learning algorithms for predictive analysis on data from international Erasmus students with course units from IPB. Performing predictive analysis for each of the algorithms and comparing the results. Predicting values for the following year for the selected machine learning algorithm.

The main scientific methods used in the thesis are general scientific (comparison, analysis, hypothesis) methods of science. The totality and combination of these methods are adequate to the purpose and objectives, object and subject of the research in this work.

1.4 Structure of the work

The first chapter describes the relevance of this work, the chosen methodology and structure.

The second chapter details the concepts of Big Data. The history of the formation of the concept of Big Data, types of Big Data and characteristics. It also describes the process of work and analysis of Big Data.

The third chapter of the thesis deals with the process of data mining. Data mining classes, neural networks and decision trees, which will be useful in further work.

Chapter four describes the tools for data analysis and the methods and techniques for each type. The data analysis algorithms are also described.

Chapter five of the thesis is the main chapter of this paper. Here, descriptive analysis, predictive analysis, and correlation will be described and worked through in detail using an example. Three machine learning algorithms for the task will be considered, the best of them will be selected and the advantages and disadvantages of each of the algorithms will be provided.

In the chapter conclusions we will describe the conclusions, results of the research, which was made in the previous chapter, and possible ways of continuing work.

The annex contains graphs of data dependencies and tables on datasets.

2. Big data

2.1 Definition of Big data technologies

Big data refers to large collections of data that are so complex and expansive that they cannot be interpreted by humans or by traditional data management systems. When properly analyzed using modern tools, these huge volumes of data give businesses the information they need to make informed decisions.

New software developments have recently made it possible to use and track big data sets. Much of this user information would seem meaningless and unconnected to the human's eye. However, big data analytic tools can track the relationships between hundreds of types and sources of data to produce useful business intelligence.[18]

Digital technology is present in all areas of human life of human life. The volume of data recorded in the world's storage facilities is growing every second, which means that at the same rate the conditions for storing information must change and new possibilities for increasing its volume must arise. [25]

According to a study by IDC Digital Universe, in the next five years the amount of data on the planet will grow to 40 zettabytes, which means that by 2020 there will be 5,200 GB for every person living on Earth. The growth graph is shown in Figure 1.[11]

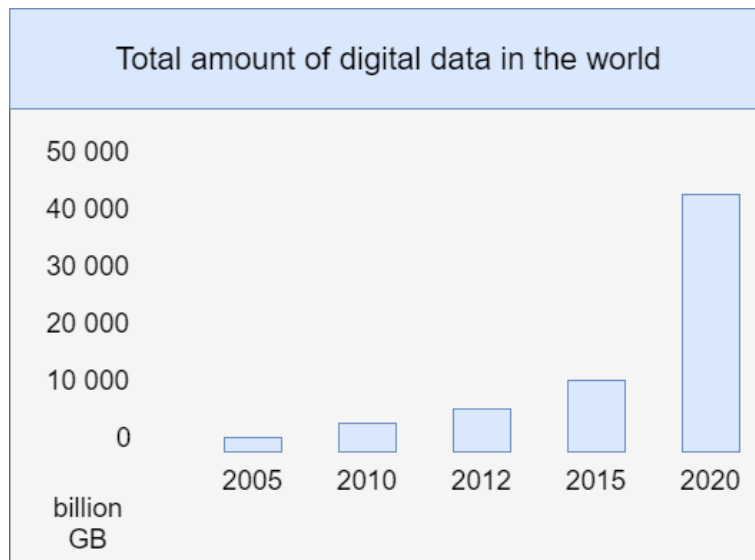

Figure 2.1: Growth of Big Data by 2020, IDC Digital Universe forecast from 2012

It is known that the main flow of information is not generated by people. The sources are robots in constant interaction with each other. These are monitoring devices, sensors, surveillance systems, personal operating systems, smartphones, smart systems, sensors, and so on. All of them set a furious growth rate of data volume, which leads to the need to increase the number of work servers (both real and virtual) - as a consequence, to expand and implement new data centers.

In fact, big data is a rather arbitrary and relative concept. The most common definition is a set of information that is larger than the hard drive of a single personal device and cannot be processed by the classic tools used for smaller volumes.

Big Data - designation of structured and unstructured data of huge volumes and significant diversity, effectively handled by horizontally scalable software tools that emerged in the late 2000s and alternatives to traditional database management systems and solutions of Business Intelligence class.

We can also use a simpler definition, which is consistent with the established opinion of journalists and marketers.

Big data is a set of technologies that are designed to perform three operations:

- Handle large volumes of data compared to "standard" scenarios.
- Be able to work with rapidly arriving data in very large volumes. That is not just a lot of data, but constantly becoming more and more.

- Be able to work with structured and unstructured data in parallel and from different angles.

These "skills" are believed to reveal hidden patterns that escape the limited human perception. This offers unprecedented opportunities to optimize many areas of our lives: public administration, medicine, telecommunications, finance, transportation, manufacturing, and so on. Not surprisingly, journalists and marketers have used the phrase Big Data so often that many experts consider the term discredited and suggest that it be abandoned.[11]

2.2 History of Big Data

Although the concept of big data itself is relatively new, the origins of large data sets go back to the 1960s and '70s when the world of data was just getting started with the first data centers and the development of the relational database.

Around 2005, people began to realize just how much data users generated through Facebook, YouTube, and other online services. Hadoop (an open-source framework created specifically to store and analyze big data sets) was developed that same year.

The development of open-source frameworks, such as Hadoop (and more recently, Spark) was essential for the growth of big data because they make big data easier to work with and cheaper to store. In the years since then, the volume of big data has skyrocketed. Users are still generating huge amounts of data—but it's not just humans who are doing it.

With the advent of the Internet of Things (IoT), more objects and devices are connected to the internet, gathering data on customer usage patterns and product performance. The emergence of machine learning has produced still more data.

While big data has come far, its usefulness is only just beginning. Cloud computing has expanded big data possibilities even further. The cloud offers truly elastic scalability, where developers can simply spin up ad hoc clusters to test a subset of data. And graph databases are becoming increasingly important as well, with their ability to display massive amounts of data in a way that makes analytics fast and comprehensive.[19]

2.3 Types of Big Data

Big Data is generally categorized into three different varieties. They are as shown below: Structured Data; Semi-Structured Data; and Unstructured Data.

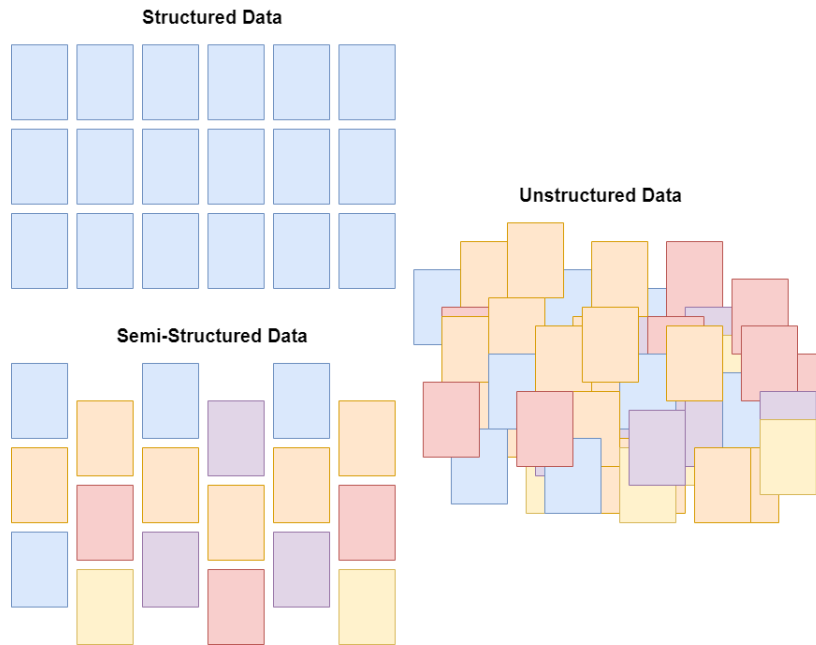

Figure 2.2: Types of Big Data

2.3.1 Structured

Structured Data owns a dedicated data model, It also has a well-defined structure, it follows a consistent order and it is designed in such a way that it can be easily accessed and used by a person or a computer. Structured data is usually stored in well-defined columns and also Databases. Example: Database Management Systems(DBMS).

Any data that can be stored, accessed and processed in the form of fixed format is termed as a ‘structured’ data. Over the period of time, talent in computer science has achieved greater success in developing techniques for working with such kind of data (where the format is well known in advance) and also deriving value out of it. However, nowadays, we are foreseeing issues when a size of such data grows to a huge extent, typical sizes are being in the rage of multiple zettabytes.[20]

Employee_ID	Employee_Name	Gender	Department	Salary_In_lacs
2365	Rajesh Kulkarni	Male	Finance	650000
3398	Pratibha Joshi	Female	Admin	650000
7465	Shushil Roy	Male	Admin	500000
7500	Shubhojit Das	Male	Finance	500000
7699	Priya Sane	Female	Finance	550000

Figure 2.3: Example of Structured Data (An 'Employee' table in a database is an example of Structured Data)[20]

2.3.2 Unstructured

Unstructured Data is completely a different type of which neither has a structure nor obeys to follow the formal structural rules of data models. It does not even have a consistent format and it found to be varying all the time. But, rarely it may have information related to data and time. Example: Audio Files, Images etc.

Any data with unknown form or the structure is classified as unstructured data. In addition to the size being huge, un-structured data poses multiple challenges in terms of its processing for deriving value out of it. A typical example of unstructured data is a heterogeneous data source containing a combination of simple text files, images, videos etc. Now day organizations have wealth of data available with them but unfortunately, they don't know how to derive value out of it since this data is in its raw form or unstructured format.[20]

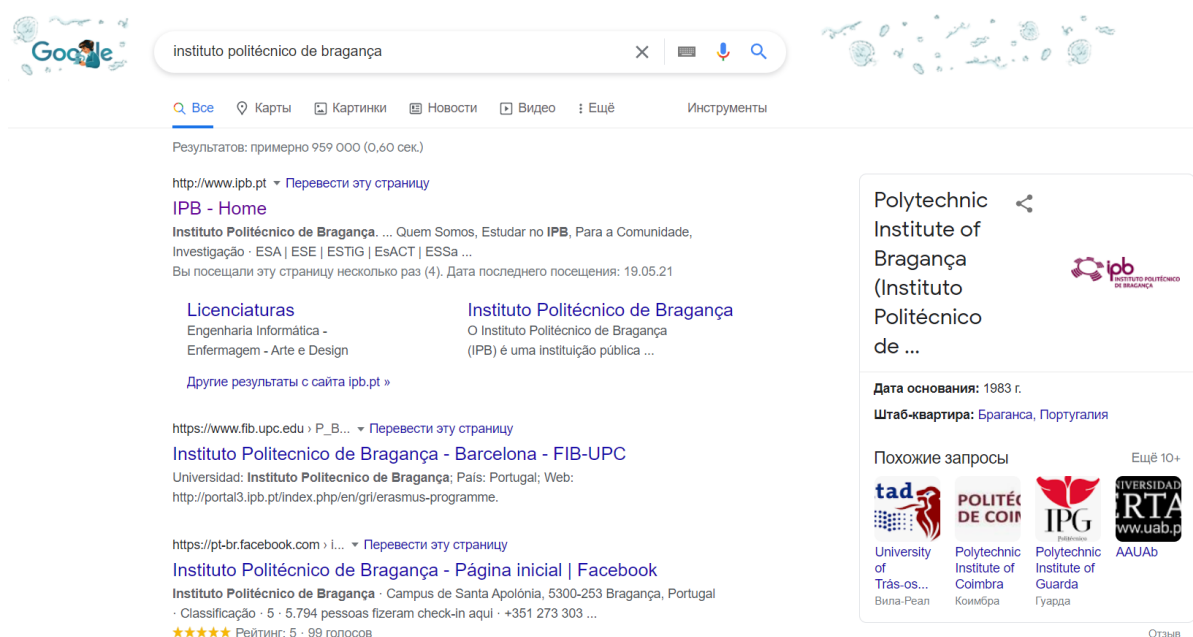

Figure 2.4: Example of Unstructured Data (The output returned by 'Google Search')

2.3.3 Semi-structured

Semi-Structured Data can be considered as another form of Structured Data. It inherits a few properties of Structured Data, but the major part of this kind of data fails to have a definite structure and also, it does not obey the formal structure of data models such as an RDBMS.

Example: Comma Separated Values(CSV) File.

Semi-structured data can contain both the forms of data. We can see semi-structured data as a structured in form but it is actually not defined with e.g. a table definition in relational DBMS.

Example of semi-structured data is a data represented in an XML file.[20]

```
<rec><name>Prashant Rao</name><sex>Male</sex><age>35</age></rec>
<rec><name>Seema R.</name><sex>Female</sex><age>41</age></rec>
<rec><name>Satish Mane</name><sex>Male</sex><age>29</age></rec>
<rec><name>Subrato Roy</name><sex>Male</sex><age>26</age></rec>
<rec><name>Jeremiah J.</name><sex>Male</sex><age>35</age></rec>
```

Figure 2.5: Example of Unstructured Data (Personal data stored in an XML file)[20]

2.4 Characteristics of Big Data

The defining characteristics for big data are, in addition to their physical volume, others that emphasize the complexity of the task of processing and analyzing these data. A set of attributes VVV (volume, velocity, variety) was developed by Meta Group in 2001 in order to indicate the equal importance of data management on all three aspects.

Later there were interpretations with four V (added veracity), five V (viability and value), seven V (variability and visualization). But the company IDC, for example, interprets the fourth V as value, emphasizing the economic feasibility of processing large amounts of data in appropriate conditions.

Based on the above definitions, the basic principles of working with big data are as follows:

- **Horizontal scalability.** This is the basic principle of big data processing. As already mentioned, big data is getting bigger every day. Accordingly, it is necessary to increase the number of computational nodes over which this data is distributed, and the processing must take place without performance degradation.

- **Fault tolerance.** This principle follows from the previous one. Since there may be many compute nodes in a cluster (sometimes tens of thousands) and their number will probably increase, the probability of machines failure also increases. Methods of working with big data must take into account the possibility of such situations and provide preventive measures.
- **Data locality.** Since the data are distributed across a large number of computing nodes, if they are physically located on one server and processed on another, data transfer costs can become unreasonably high. Therefore, it is desirable to process the data on the same machine where it is stored.

These principles differ from those characteristic of traditional, centralized, vertical models for storing well-structured data. Accordingly, new approaches and technologies are being developed to handle big data.

- **Volume.** Volume refers to the unimaginable amounts of information generated every second from social media, cell phones, cars, credit cards, M2M sensors, images, video, and whatnot. We are currently using distributed systems, to store data in several locations and brought together by a software Framework like Hadoop. Facebook alone can generate about billion messages, 4.5 billion times that the “like” button is recorded, and over 350 million new posts are uploaded each day. Such a huge amount of data can only be handled by Big Data Technologies.
- **Variety.** As Discussed before, Big Data is generated in multiple varieties. Compared to the traditional data like phone numbers and addresses, the latest trend of data is in the form of photos, videos, and audios and many more, making about 80% of the data to be completely unstructured.
- **Veracity.** Veracity basically means the degree of reliability that the data has to offer. Since a major part of the data is unstructured and irrelevant, Big Data needs to find an alternate way to filter them or to translate them out as the data is crucial in business developments.
- **Value.** Value is the major issue that we need to concentrate on. It is not just the amount of data that we store or process. It is actually the amount of valuable, reliable and trustworthy data that needs to be stored, processed, analyzed to find insights.

- **Velocity.** Velocity plays a major role compared to the others, there is no point in investing so much to end up waiting for the data. So, the major aspect of Big Data is to provide data on demand and at a faster pace.[21]

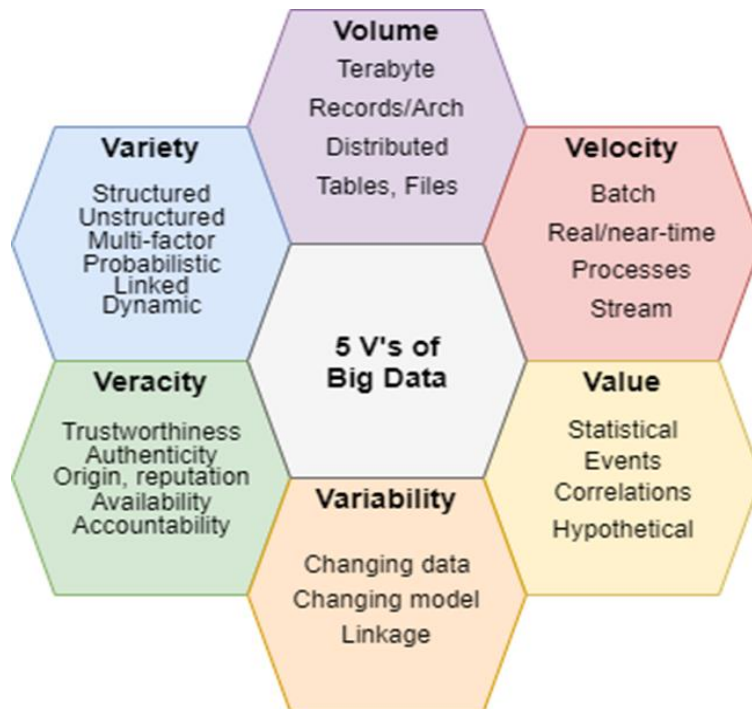

Figure 2.6: 5 V's of Big Data

2.5 How big data works

Big data gives new insights that open up new opportunities and business models. Getting started involves three key actions:

- **Integrate.** Big data brings together data from many disparate sources and applications. Traditional data integration mechanisms, such as extract, transform, and load (ETL) generally aren't up to the task. It requires new strategies and technologies to analyze big data sets at terabyte, or even petabyte, scale.
- **Manage.** Big data requires storage. A storage solution can be in the cloud, on premises, or both. We can store a data in any form want and bring desired processing requirements and necessary process engines to those data sets on an on-demand basis. Many people choose their storage solution according to where their

data is currently residing. The cloud is gradually gaining popularity because it supports current compute requirements and enables to spin up resources as needed.

- **Analyze.** An investment in big data pays off when analyze and act on a data. Get new clarity with a visual analysis of varied data sets. Explore the data further to make new discoveries. Share findings with others. Build data models with machine learning and artificial intelligence. Put a data to work.[19]

2.6 Technologies and trends of working with Big Data

Initially, the set of approaches and technologies included tools for mass-parallel processing of indefinitely structured data, Map Reduce algorithms and Hadoop project tools. Later on, other solutions providing similar features for processing super large data arrays, as well as some hardware, began to be attributed to big data technologies.

Hadoop is a freely distributed set of utilities, libraries and frameworks for developing and executing distributed programs running on clusters of hundreds or thousands of nodes. It is considered one of the foundational technologies of big data.

R is a programming language for statistical data processing and graphics. It is widely used for data analysis and has actually become a standard for statistical programs.

Hardware solutions. Teradata, EMC and other corporations offer hardware and software complexes designed for big data processing. These complexes are supplied as ready-to-install telecommunication cabinets containing a cluster of servers and control software for mass-parallel processing. Hardware solutions for analytical in-memory processing, such as SAP's Hana hardware and software complexes and Oracle's Exalytics complex, are also sometimes referred to here, despite the fact that such processing is not massively parallel, and the RAM capacity of one node is limited to several terabytes.

Map Reduce is a model of distributed parallel computing in computer clusters introduced by Google. According to this model, an application is divided into a large number of identical elementary tasks, executed on the nodes of the cluster and then naturally summarized in the final result.

Map Reduce can be rightfully called the main Big Data technology, since it is initially focused on parallel computing in distributed clusters. The essence of Map Reduce is to divide the information array into parts, process each part in parallel on a separate node and finally combine all the results.

Programs using Map Reduce are automatically parallelized and executed on distributed cluster nodes, with the runtime system itself taking care of implementation details (splitting input data into parts, dividing tasks by cluster nodes, handling failures and communication between distributed computers). This allows programmers to easily and efficiently use the resources of distributed Big Data systems.

The technology is practically universal: it can be used to index web content, count words in a large file, count the frequency of hits to a given address, calculate the volume of all web pages from each URL of a particular host, create a list of all addresses with required data and other tasks of processing huge arrays of distributed information. Other applications of Map Reduce include distributed data search and sorting, web link graph manipulation, network log statistics processing, inverted index building, document clustering, machine learning and statistical machine translation. Map Reduce is also adapted to multiprocessor systems, voluntary computing, dynamic cloud and mobile environments.

The computational model itself consists of a 3-step combination of the above functions:

- Map is a preprocessing of input data in the form of a large list of values. The cluster master node receives this list, divides it into parts, and passes it to the worker nodes. Then each worker node applies the Map function to the local data and writes the result in key-value format to the temporary storage.
- The `map()` function applied to one input record and outputs a set of key-value pairs. Multiple - i.e. it may output only one record, it may output nothing, or it may output several key-value pairs. What is in the key and value is up to the user, but the key is a very important thing, because data with one key in the future will end up in one instance of the reduce function.
- Shuffle, when work nodes redistribute data based on the keys previously created by the Map function, so that all data of one key lies on one work node.

- Reduce - each worker node processes each group of data in parallel, in order of keys, and "glues" the results to the master node. The master node receives intermediate answers from worker nodes and passes them to free nodes to perform the next step. The result obtained after passing all necessary steps is the solution to the original problem.

The reduce function is user-defined and calculates the final result for a single "garbage can". The set of all values returned by reduce() is the final result of the Map Reduce problem.[11]

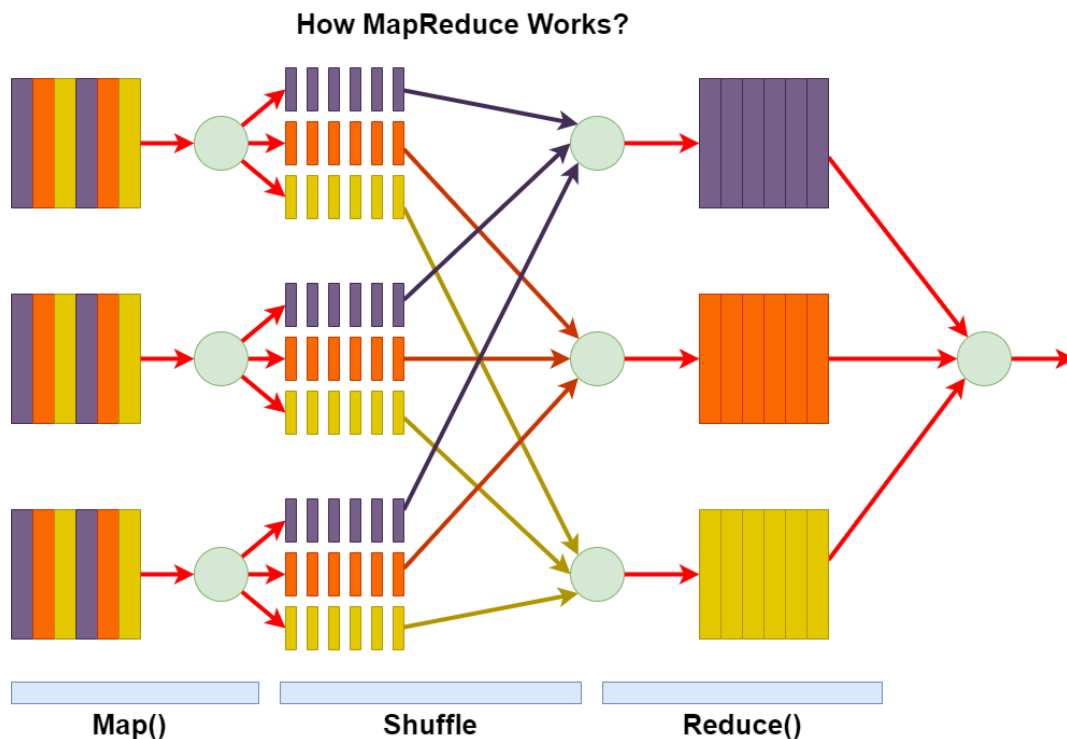

Figure 2.7: Map Reduce

2.7 Big Data Analysis Methods and Techniques

Usually there are 11 methods and techniques of analysis applicable to big data:

- Data Mining - a set of methods for discovering previously unknown, non-trivial, practically useful knowledge in data, necessary for decision making. Such methods, in particular, include association rule learning, classification, cluster analysis, regression analysis, detection and analysis of variance, etc.

- Crowdsourcing - the classification and enrichment of data by a wide, unspecified circle of people doing the work without entering into an employment relationship.
- Data blending and integration - a set of techniques that integrate heterogeneous data from a variety of sources for the purpose of in-depth analysis (e.g., digital signal processing, natural language processing, including tonal analysis, etc.).
- Machine learning, including with and without a teacher - using models based on statistical analysis or machine learning to produce complex predictions based on underlying models.
- Artificial neural networks, network analysis, optimization, including genetic algorithms (genetic algorithm - heuristic search algorithms used to solve optimization and modeling problems by random selection, combination and variation of required parameters using mechanisms similar to natural selection in nature).
- Simulation modeling is a method that allows to build models that describe processes as they would occur in reality. Simulation modeling can be considered as a form of experimental testing.
- Spatial analysis is a class of methods that use topological, geometric, and geographic information extracted from data.
- Statistical analysis - time series analysis, A/B testing (A/B testing, split testing - a method of market research; when it is used, a control group of elements is compared with a set of test groups in which one or more indicators have been changed, in order to see which changes improve the target indicator).
- Visualization of analytical data - the presentation of information in the form of drawings, diagrams, using interactive features and animation for both the results and for use as input data for further analysis. A very important stage of big data analysis, which allows to present the most important results of the analysis in the most convenient form for perception.[20]

2.8 Big Data in industry

By using big data, companies can gain a tangible competitive advantage. Big Data technologies can be useful for the following tasks:

- market forecasting
- marketing and sales optimization
- product improvement
- management decision-making
- increasing productivity
- efficient logistics
- monitoring the condition of fixed assets

In manufacturing plants, big data is also generated by the introduction of Industrial Internet of Things technologies. In this process, the main assemblies and parts of machines and machines are equipped with sensors, actuators, controllers and, sometimes, inexpensive processors capable of performing boundary calculations. During the production process, data are continuously collected and possibly pre-processed. Analytical platforms process these massive amounts of information in real time, present the results in the most digestible form and store them for future use. Based on the analysis of the data obtained, conclusions are made about the condition of the equipment, its efficiency, the quality of products, the need to make changes in manufacturing processes, etc.

Thanks to the real-time monitoring of information, the staff of the enterprise can: cut downtime; enhance performance; reduce the cost of operating the equipment; and prevent accidents.

The last point is particularly important. For example, operators working in the petro-chemical industry receive an average of about 1,500 emergency messages per day, which is more than one message per minute. This leads to increased fatigue for operators, who have to constantly make instant decisions on how to respond to a particular signal. But an analytics platform can filter out the secondary information, so operators are able to focus on critical situations first. This allows them to more effectively identify and prevent accidents and possibly accidents.

As a result, levels of production reliability, industrial safety, process equipment availability, and regulatory compliance increase.

In addition, the results of big data analysis can be used to calculate the payback period of the equipment, the prospects for changing technological modes, reducing or redistributing the staff, i.e. to make strategic decisions regarding the further development of the enterprise.

Big Data is considered the most valuable and powerful fuel that can run the massive IT industries of the 21st Century. Big Data is being the most wide-spread technology that is being used in almost every business sector. Let us now check out a few as mentioned below.

Travel and Tourism is one of the biggest users of Big Data Technology. It has enabled us to predict the requirements for travel facilities in many places, improving business through dynamic pricing and many more.

Financial and Banking Sectors extensively uses Big Data Technology. Big data analytics can aid banks in understanding customer behavior based on the inputs received from their investment patterns, shopping trends, motivation to invest and personal or financial backgrounds.

Big Data has already started to create a huge difference in the **healthcare** sector. With the help of predictive analytics, medical professionals and Health Care Personnel are now able to provide personalized healthcare services to individual patients.

Telecommunication and Multimedia sector is one of the primary users of Big Data. There are zettabytes of getting generated every day and to handle such huge data would need nothing other than Big Data Technologies.

Government and Military also use Big Data Technology at a higher rate. We can consider the amount of data Government generates on its records and in the military, a normal fighter jet plane requires to process petabytes of data during its flight.[29]

3. Data Mining

3.1 Definition

Data mining, also known as knowledge discovery in data (KDD), is the process of uncovering patterns and other valuable information from large data sets. Given the evolution of data warehousing technology and the growth of big data, adoption of data mining techniques has rapidly accelerated over the last couple of decades, assisting companies by transforming their raw data into useful knowledge. However, despite the fact that that technology continuously evolves to handle data at a large-scale, leaders still face challenges with scalability and automation.

Data mining has improved organizational decision-making through insightful data analyses. The data mining techniques that underpin these analyses can be divided into two main purposes; they can either describe the target dataset or they can predict outcomes through the use of machine learning algorithms. These methods are used to organize and filter data, surfacing the most interesting information, from fraud detection to user behaviors, bottlenecks, and even security breaches.

The data mining process involves a number of steps from data collection to visualization to extract valuable information from large data sets. As mentioned above, data mining techniques are used to generate descriptions and predictions about a target data set. Data scientists describe data through their observations of patterns, associations, and correlations. They also classify and cluster data through classification and regression methods, and identify outliers for use cases, like spam detection.

Data mining usually consists of four main steps: setting objectives, data gathering and preparation, applying data mining algorithms, and evaluating results.[27]

3.2 Classes of Data Mining Systems

Data mining works by using various algorithms and techniques to turn large volumes of data into useful information. Here are some of the most common ones:[27]

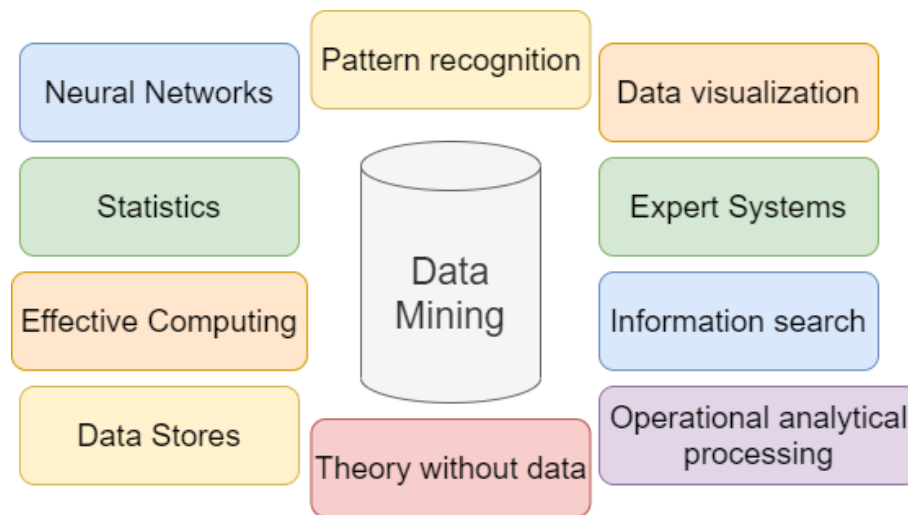

Figure 3.1: Data Mining is a multidisciplinary field

3.2.1 Object-oriented analytical systems

Subject-oriented analytical systems are very diverse. The broadest subclass of such systems, which has become widespread in the field of financial market research, is called "technical analysis". It represents the totality of several dozens of methods for forecasting price dynamics and choosing the optimal structure of an investment portfolio, based on various empirical models of market dynamics. These methods often use simple statistical apparatus, but as much as possible take into account specifics of the field (professional language, systems of different indexes, etc.). There are a lot of programs of this class on the market. As a rule, they are rather cheap (usually \$300-1000).[27]

3.2.2 Statistical packages

The latest versions of almost all well-known statistical packages include, along with traditional statistical methods, elements of Data Mining. But the main attention is paid to the classical methods: correlation, regression, factor analysis, and others. The disadvantage of systems of this class is considered to be the requirement for special training of the user. It is also noted that powerful modern statistical packages are too "heavyweight" for mass application in finance and business. In addition, these systems are often quite expensive: from \$1000 to \$15000.

There is an even more serious fundamental drawback of statistical packages, which limits their application in Data Mining. Most of the methods included in the packages are based on the statistical paradigm, in which the main figures are the averaged characteristics of the sample. And these characteristics, as indicated above, in the study of real complex life phenomena are often fictitious values. Examples of the most powerful and widespread statistical packages are

SAS (SAS Institute company), SPSS (SPSS), STATGRAPICS (Manugistics), STATISTICA, STADIA and others.[27]

3.2.3 Neural networks

This is a large class of systems, the architecture of which is analogous to the construction of neural tissue from neurons. One of the most common architectures, multilayer perceptron with backward error propagation, simulates the work of neurons in a hierarchical network, where each neuron of a higher level is connected by its inputs to the outputs of the neurons of a lower layer. Neurons of the lowest layer receive values of input parameters, on the basis of which it is necessary to make some decisions, predict the development of the situation, etc. These values are considered as signals transmitted to the next layer, weakening or intensifying depending on numerical values (weights) assigned to inter-neuron connections. As a result, the output of the neuron of the uppermost layer produces some value, which is treated as a response - the response of the whole network to the input parameter values. To be able to use the network in the future, it must first be "trained" on previously obtained data, for which both values of input parameters and correct responses to them are known. The training consists in selection of weights of inter-neuron connections, providing the closest proximity of network answers to the known correct answers.

The main disadvantage of the neural network paradigm is the need to have a very large training sample size. Another significant disadvantage is that even a trained neural network is a black box. Knowledge, fixed as weights of several hundreds of inter-neuron connections, does not lend itself to human analysis and interpretation at all (known attempts to interpret the structure of a tuned neural network look unconvincing – the "KINOsuite-PR" system).

Examples of neural network systems are BrainMaker (CSS), NeuroShell (Ward Systems Group), OWL (HyperLogic). Their cost is quite considerable: \$1500-8000.[27]

3.2.4 Systems of reasoning based on similar cases

The idea of case based reasoning systems - CBR - is, at first glance, extremely simple. In order to make predictions about the future or to choose the right decision, these systems find close analogues of the present situation in the past and choose the same answer that was correct for them. That is why this method is also called the nearest-neighbor method. Recently, the term memory based reasoning has also spread, which emphasizes that the decision is made on the basis of all information accumulated in memory.

CBR systems show good results in a variety of tasks. Their main disadvantage is that they do not create any models or rules, generalizing previous experience - in choosing a solution, they are based on the entire array of available historical data, so it is impossible to say on what specific factors CBR systems build their answers.

Another disadvantage is the arbitrariness that CBR systems allow in choosing the measure of "proximity. The amount of multiple precedents that need to be stored in memory to achieve a satisfactory classification or prediction depends most decisively on this measure.

Examples of systems using CBR are KATE tools (Acknosoft, France), Pattern Recognition Workbench (Unica, USA).[27]

3.2.5 Decision trees

Decision trees are one of the most popular approaches to solving Data Mining problems. They create a hierarchical structure of classification rules such as "IF... THEN..." (if-then), which has the form of a tree. To decide which class to assign an object or situation to, we need to answer the questions at the nodes of the tree, starting from the root. The questions have the form "the value of parameter A is greater than x". If the answer is positive, we go to the right node of the next level, if negative, we go to the left node, followed again by the question associated with the corresponding node.

The popularity of the approach is related as it is to the clarity and comprehensibility. But decision trees are fundamentally unable to find the "best" (most complete and accurate) rules in the data. They implement the naive principle of sequential viewing of features and "cling" actually fragments of real patterns, creating only the illusion of logical inference. At the same time, most systems use exactly this method. The best known are See5/C5.0 (RuleQuest, Australia), Clementine (Integral Solutions, UK), SIPINA (University of Lyon, France), IDIS (Information Discovery, USA), KnowledgeSeeker (ANGOSS, Canada). Their cost is quite considerable: \$1000-10000.[27]

3.2.6 Evolutionary Programming

Let me illustrate the current state of this approach on the example of the PolyAnalyst system, a domestic development that has gained general recognition on the Data Mining market today. In this system, hypotheses about the type of dependence of the target variable on other variables are formulated in the form of programs in some internal programming language. The process of building programs is constructed as an evolution in the world of programs (this approach is a bit like genetic algorithms). When the system finds a program that more or less

satisfactorily expresses the desired dependence, it begins to make small modifications to it and selects among the constructed daughter programs those that increase the accuracy. Thus the system "grows" several genetic lines of programs which compete with each other in the accuracy of expression of the sought dependence. A special module of PolyAnalyst system translates the found dependences from the internal language of the system into a user-understandable language (mathematical formulas, tables etc.).

The other direction of evolutionary programming is associated with the search of target variables dependencies on the other variables in the form of functions of some particular kind. For example, in one of the most successful algorithms of this type, the method of group accounting of arguments (MGUA), the dependence is sought in the form of polynomials. At the present time, of the systems sold in Russia, MGUA is implemented in the NeuroShell system of Ward Systems Group. The systems cost up to \$5000.[27]

3.2.7 Genetic algorithms

Data Mining is not the main application area of genetic algorithms. They should rather be considered as a powerful tool for solving a variety of combinatorial and optimization problems. Nevertheless, genetic algorithms are now part of the standard toolset of DataMining methods, so they are included in this review.

The first step in constructing genetic algorithms is to encode the original logical patterns in the database, which are called chromosomes, and the entire set of such patterns is called a chromosome population. Next, a way of matching different chromosomes is introduced to implement the concept of selection. The population is processed using procedures of reproduction, variability (mutations), and genetic composition. These procedures mimic biological processes. The most important among them are: random data mutations in individual chromosomes, transitions (crossing over) and recombination of genetic material contained in individual parental chromosomes (similar to heterosexual reproduction), and gene migrations. The procedures at each stage of evolution produce populations with increasingly better individuals.

Genetic algorithms are convenient because they are easy to parallelize. For example, it is possible to divide a generation into several groups and work with each of them independently, exchanging a few chromosomes from time to time. There are also other methods of paralleling genetic algorithms.

Genetic algorithms have a number of drawbacks. The chromosome selection criterion and the procedures used are heuristic and far from guaranteeing a "best" solution. As in real life, evolution may "get stuck" on some unproductive branch. Conversely, one can give examples of how two unproductive parents, which would be excluded from evolution by a genetic algorithm, turn out to be capable of producing a highly efficient offspring. This becomes especially noticeable when solving high-dimensional problems with complex internal connections.

An example is the GeneHunter system by Ward Systems Group. Its cost is about \$1000.[27]

3.2.8 Constrained search algorithms

Bounded search algorithms were proposed in the mid-60s by M.M. Bongard to search for logical patterns in data. Since then, they have demonstrated their effectiveness in solving many problems from a wide variety of fields.

These algorithms calculate frequencies of combinations of simple logical events in subsets of data. Examples of simple logical events: $X = a$; $X < a$; $X \geq a$; $a < X < b$, etc., where X is some parameter, "a" and "b" are constants. The limitation is the length of the combination of simple logical events (M. Bongard had it equal to 3). Based on the analysis of the calculated frequencies, a conclusion is made about the usefulness of this or that combination for establishing an association in the data, for classification, prediction, etc.

The most striking modern representative of this approach is the WizWhy system of the WizSoft company. Although the author of the system, Abraham Meydan, does not disclose the specifics of the algorithm underlying WizWhy, the results of thorough testing of the system have led to conclusions about the presence here of limited enumeration (studied the results, the dependence of the time of their receipt on the number of parameters analyzed, etc.).

The author of WizWhy claims that his system detects ALL logical if-then rules in the data. In reality, of course, this is not the case. First, the maximum combination length in an if-then rule in the WizWhy system is 6, and, second, from the very beginning of the algorithm, a heuristic search for simple logical events, on which all further analysis is then based, is performed. Having understood these features of WizWhy, it was not difficult to propose the simplest test problem, which the system could not solve at all. Another point is that the system produces a solution in an acceptable time only for a relatively small dimensionality of the data.

Nevertheless, the WizWhy system is currently one of the leaders in the market of Data Mining products. This is not without reason. The system consistently demonstrates better performance in solving practical problems than all other algorithms. The cost of the system is about \$4,000, and the number of sales is 30,000.[27]

3.2.9 Systems for visualizing multidimensional data

In one way or another, the means for graphical displaying of data are supported by all Data Mining systems. At the same time, a very large share of the market is occupied by systems that specialize exclusively in this function. An example of this is the DataMiner3D program of the Slovak company Dimension5. In such systems, the main attention is concentrated on the friendliness of the user interface, which allows to associate various parameters of the scatter diagram of database objects (records) with the analyzed indicators. Such parameters include color, shape, orientation relative to its own axis, size and other properties of graphic elements of the image. In addition, the data visualization systems are provided with convenient tools for scaling and rotation of images. The cost of visualization systems can reach several hundred dollars.[27]

3.3 Results

- The market for Data Mining systems is growing exponentially. Almost all major corporations participate in this development. In particular, Microsoft directly manages a large sector of this market (publishes a special magazine, holds conferences, develops its own products).
- Data Mining systems are used in two main directions: 1) as a mass product for business applications; 2) as tools for unique research (genetics, chemistry, medicine, etc.). At present the cost of mass product is from \$1000 to \$10000. The number of mass product installations, according to available information, today reaches tens of thousands. Data Mining leaders link the future of these systems with their use as intelligent applications embedded in corporate data warehouses.
- Despite the abundance of Data Mining methods, the priority is gradually shifting towards logical algorithms to search for if-then rules in the data. They are used to solve problems of prediction, classification, pattern recognition, database

segmentation, extraction of "hidden" knowledge from data, data interpretation, establishing associations in the database, etc. The results of such algorithms are efficient and easy to interpret.

- At the same time, the main problem of logical methods of pattern detection is the problem of trying variants in a reasonable time. Known methods either artificially limit such a search (algorithms KORA, WizWhy), or build decision trees (algorithms CART, CHAID, ID3, See5, Sipina, etc.), which have fundamental efficiency limitations for searching if-then rules. Other problems are related to the fact that known methods of search for logical rules do not support the function of generalization of found rules and the function of search for the optimal composition of such rules. A successful solution to the above problems can form the subject of new competitive developments.[27]

4. Data transfer, analysis and processing

4.1 Definition

Data analysis is defined as a process of cleaning, transforming, and modeling data to discover useful information for business decision-making. The purpose of Data Analysis is to extract useful information from data and taking the decision based upon the data analysis.

A simple example of Data analysis is whenever we take any decision in our day-to-day life is by thinking about what happened last time or what will happen by choosing that particular decision. This is nothing but analyzing our past or future and making decisions based on it. For that, we gather memories of our past or dreams of our future. So that is nothing but data analysis. Now same thing analyst does for business purposes, is called Data Analysis.[28]

4.2 Data Analysis Tools

Data analysis tools make it easier for users to process and manipulate data, analyze the relationships and correlations between data sets, and it also helps to identify patterns and trends for interpretation. Here is a complete list of tools used for data analysis in research.



Figure 4.1: Data Analysis Tools[28]

4.3 Types of Data Analysis: Techniques and Methods

- **Text Analysis.** Text Analysis is also referred to as Data Mining. It is one of the methods of data analysis to discover a pattern in large data sets using databases or data mining tools. It used to transform raw data into business information. Business Intelligence tools are present in the market which is used to take strategic business decisions. Overall it offers a way to extract and examine data and deriving patterns and finally interpretation of the data.
- **Statistical Analysis.** Statistical Analysis shows "What happen?" by using past data in the form of dashboards. Statistical Analysis includes collection, Analysis, interpretation, presentation, and modeling of data. It analyses a set of data or a sample of data. There are two categories of this type of Analysis - Descriptive Analysis (analyses complete data or a sample of summarized numerical data. It shows mean and deviation for continuous data whereas percentage and frequency for categorical data) and Inferential Analysis (analyses sample from complete data. In this type of Analysis, we can find different conclusions from the same data by selecting different samples).
- **Diagnostic Analysis.** Diagnostic Analysis shows "Why did it happen?" by finding the cause from the insight found in Statistical Analysis. This Analysis is useful to identify behavior patterns of data. If a new problem arrives in a business process, then we can look into this Analysis to find similar patterns of that problem. And it may have chances to use similar prescriptions for the new problems.
- **Predictive Analysis.** Predictive Analysis shows "what is likely to happen" by using previous data. The simplest data analysis example is like if last year I bought two dresses based on my savings and if this year my salary is increasing double then I can buy four dresses. But of course it's not easy like this because we have to think about other circumstances like chances of prices of clothes is increased this year or maybe instead of dresses we want to buy a new bike, or we need to buy a house! So here, this Analysis makes predictions about future outcomes based on current or past data. Forecasting is just an estimate. Its accuracy is based on how much detailed information we have and how much we dig in it.

- **Prescriptive Analysis.** Prescriptive Analysis combines the insight from all previous Analysis to determine which action to take in a current problem or decision. Most data-driven companies are utilizing Prescriptive Analysis because predictive and descriptive Analysis are not enough to improve data performance. Based on current situations and problems, they analyze the data and make decisions.[28]

4.4 Correlation

4.4.1 Determining correlation

Correlation analysis is a powerful statistical tool used for the analysis of many different data across many different fields of study. Correlation matrices can help identify relationships among a great number of variables in a way that can be interpreted easily—either numerically or visually. Creating heatmaps from correlation matrices in Python is one such example.

Correlation is a relationship of dependency between variables where a change in the observed value of one variable is reflected by a unit change in another. Correlations are used to develop statistical models in machine learning as well as more traditional methods such as multiple and simple linear regression.

Correlation is a numerical description of the linear relationship between two variables. It describes the amount of change in one variable in response to a unit change in another variable. For example; the price of a stock has a positive correlation with positive earnings reports. When an earnings report is positive the stock price is likely to move positively in response.

4.4.2 Correlation Matrices

Machine Learning models are as good or as bad as the data we have. That's why data scientists can spend hours on pre-processing and cleansing the data. They select only the features that would contribute most to the quality of the resulting model. This process is called "Feature Selection". Feature Selection is the process of selecting the attributes that can make the predicted variable more accurate or eliminating those attributes that are irrelevant and can decrease the model accuracy and quality.

Data Correlation: Is a way to understand the relationship between multiple variables and attributes in a dataset. Using Correlation, we can get some insights such as:

- One or multiple attributes depend on another attribute or a cause for another attribute.
- One or multiple attributes are associated with other attributes.

The benefits of correlation:

- Correlation can help in predicting one attribute from another (Great way to impute missing values).
- Correlation can (sometimes) indicate the presence of a causal relationship.
- Correlation is used as a basic quantity for many modelling techniques

There are three types of correlations:

- 1) **Positive Correlation:** means that if feature A increases then feature B also increases or if feature A decreases then feature B also decreases. Both features move in tandem and they have a linear relationship.
- 2) **Negative Correlation:** means that if feature A increases then feature B decreases and vice versa.
- 3) **No Correlation:** No relationship between those two attributes.

Each of those correlation types can exist in a spectrum represented by values from 0 to 1 where slightly or highly positive correlation features can be something like 0.5 or 0.7. If there is a strong and perfect positive correlation, then the result is represented by a correlation score value of 0.9 or 1. If there is a strong negative correlation, it will be represented by a value of -1.

If a dataset has perfectly positive or negative attributes, then there is a high chance that the performance of the model will be impacted by a problem called — “Multicollinearity”. Multicollinearity happens when one predictor variable in a multiple regression model can be linearly predicted from the others with a high degree of accuracy. This can lead to skewed or misleading results. Luckily, decision trees and boosted trees algorithms are immune to multicollinearity by nature. When they decide to split, the tree will choose only one of the perfectly correlated features. However, other algorithms like Logistic Regression or Linear Regression are not immune to that problem and we should fix it before training the model.

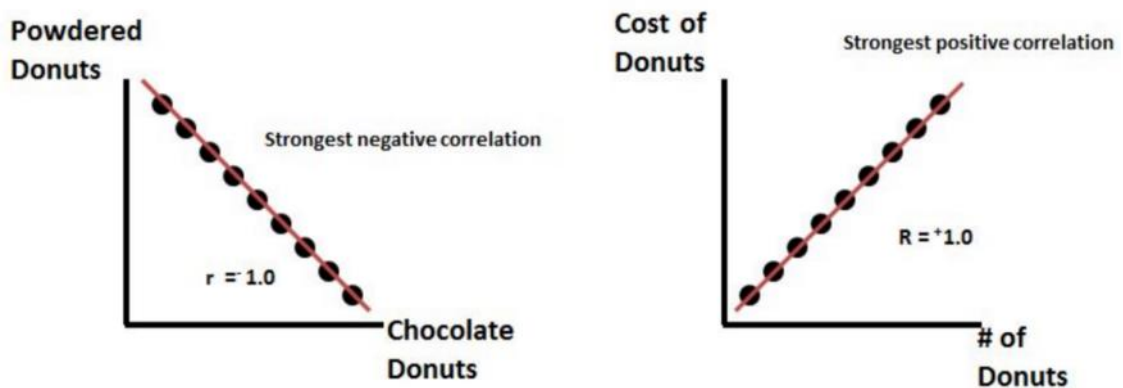

Figure 5.25: Types of correlations

4.5 Machine learning algorithms for data processing

There is such a concept as the "No Free Lunch" theorem. Its essence is that there is no algorithm that is the best choice for every task, which is especially true for learning with a teacher.

For example, we can't say that neural networks always perform better than decision trees, and vice versa. The performance of algorithms is affected by many factors like the size and structure of the dataset.

For this reason, we have to try many different algorithms, checking the efficiency of each one on a test dataset, and then choosing the best one. Of course, we have to choose among algorithms that are appropriate for a problem.

Machine learning algorithms can be described as learning the target function f that best relates the input variable X to the output variable Y : $Y = f(X)$. We do not know what the function f is. After all, if we did, we would use it directly instead of trying to train it using various algorithms. The most common task in machine learning is to predict values of Y for new values of X . This is called predictive modeling, and our goal is to make as accurate a prediction as possible.

Below is a brief overview of the top 10 popular algorithms used in machine learning: Linear regression; Logistic regression; Linear discriminant analysis; Decision tree; Naive bayesian lassifier; K-nearest neighbors.[25]

4.5.1 Linear regression

Linear regression is probably one of the best known and best understood algorithms in statistics and machine learning. Predictive modeling is primarily concerned with minimizing model error or, in other words, with making predictions as accurate as possible. We will borrow algorithms from various fields, including statistics, and use them for this purpose. Linear regression can be represented as an equation that describes the straight line that most accurately shows the relationship between input variables X and output variables Y. In order to make this equation, we need to find certain B coefficients for the input variables.

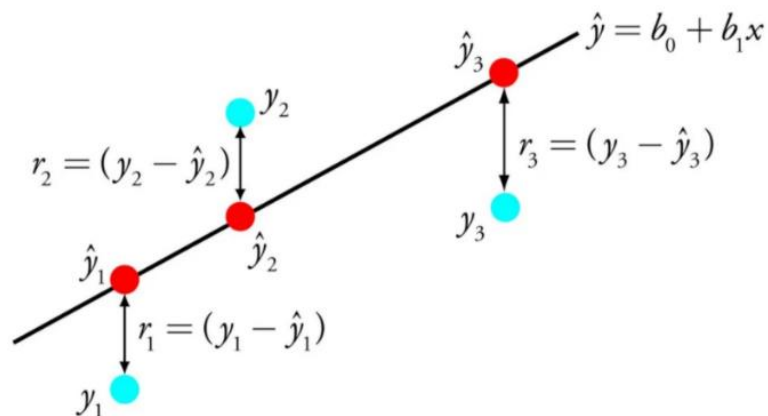

Figure 4.2: Linear regression[25]

For example: $Y = B_0 + B_1 * X$

Knowing X, we have to find Y, and the goal of linear regression is to find the values of B_0 and B_1 . Various methods like linear algebra or least squares are used to estimate a regression model. Linear regression has been around for over 200 years, and in that time it has been studied extensively. So here are a couple of rules of thumb: remove similar (correlated) variables and get rid of noise in the data, if possible. Linear regression is a fast and simple algorithm that works well as a first algorithm to learn.[25]

Advantages:

- Very fast, can work on very large samples
- Practically out of competition, when there are a lot of features (from hundreds of thousands or more), and they are sparse (although there is still factorization machines)

- Coefficients in front of features can be interpreted (provided that features are scaled) - in linear regression as partial derivatives of the dependent variable on features, in logistic regression - as a change in the chances of assignment to one of the classes $\exp\beta_i$ times when the feature x_i changes by 1 unit.
- Logistic regression gives the probabilities of assignment to different classes (this is very valuable, for example, in credit scoring)
- The model can also build a nonlinear boundary if polynomial features are input

Disadvantages:

- They work poorly in problems in which the dependence of responses on signs is complex, nonlinear
- In practice, the assumptions of the Markov-Gauss theorem are almost never fulfilled, therefore, more often linear methods perform worse than, for example, SVM and ensembles (in terms of the quality of solving the classification / regression problem).

4.5.2 Logistic regression

Logistic regression is another algorithm that came to machine learning directly from statistics. It is good to use for binary classification problems (these are problems in which the output is one of two classes). Logistic regression is similar to linear regression in that it also requires finding coefficient values for input variables. The difference is that the output value is transformed using a non-linear or logistic function.

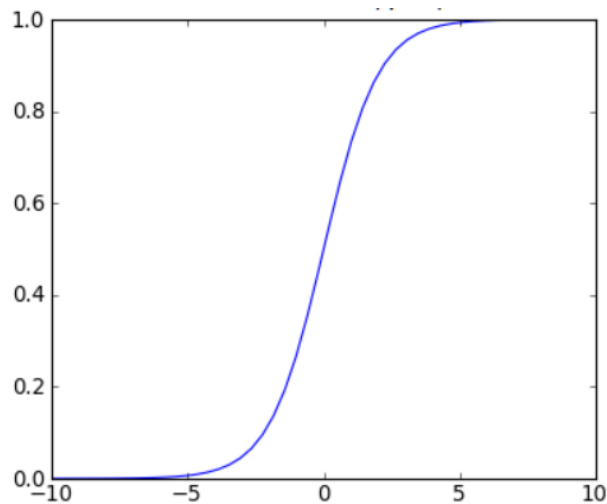

Figure 4.3: Logistic function[25]

A logistic function looks like a big letter S and converts any value into a number between 0 and 1. This is very useful because we can apply a rule to the output of a logistic function to bind to 0 and 1 (for example, if the result of the function is less than 0.5, then we get 1 in the output) and predict the class.

Because of the way the model is trained, logistic regression predictions can be used to represent the probability of a sample belonging to class 0 or 1. This is useful in cases where we need more justification for a prediction. As with linear regression, logistic regression performs its task better when redundant and similar variables are removed. The logistic regression model learns quickly and is well suited to binary classification tasks.[25]

4.5.3 Linear Discriminant Analysis (LDA)

Logistic regression is used when we want to assign a sample to one of two classes. If there are more than two classes, it is better to use the LDA (Linear discriminant analysis) algorithm. The representation of LDA is quite simple. It consists of statistical properties of the data calculated for each class. For each input variable this includes: “The average value for each class” and “The variance calculated for all classes”.

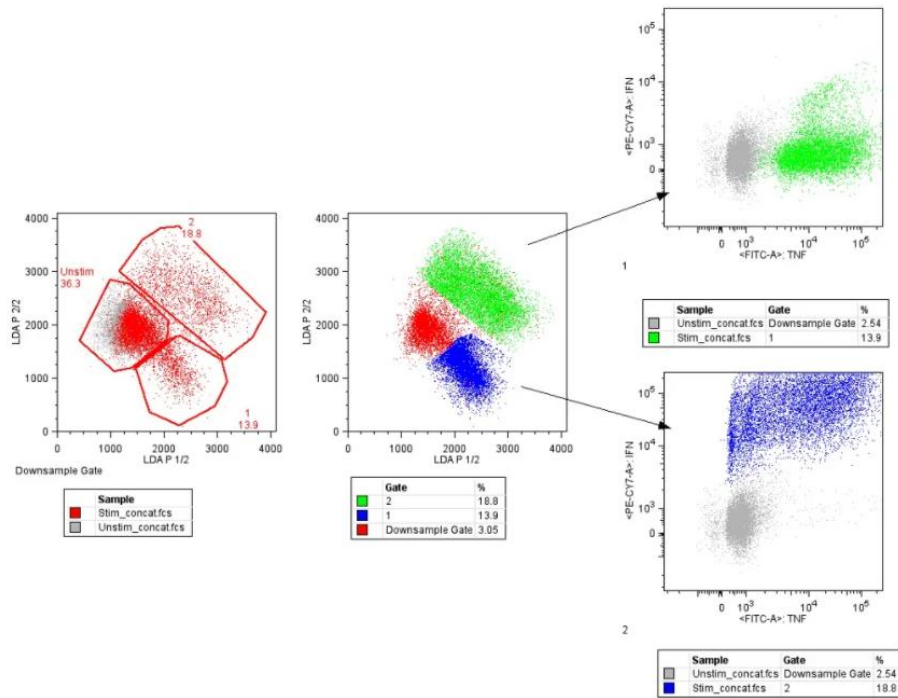

Figure 4.4: Linear Discriminant Analysis[25]

Predictions are made by calculating the discriminant value for each class and selecting the class with the highest value. The data is assumed to have a normal distribution, so it is recommended to remove abnormal values from the data before starting. This is a simple and efficient algorithm for classification problems.[25]

4.5.4 Decision trees

A decision tree can be represented as a binary tree, familiar to many people from algorithms and data structures. Each node represents an input variable and a split point for that variable (assuming the variable is a number). The leaf nodes are the output variable that is used for prediction.

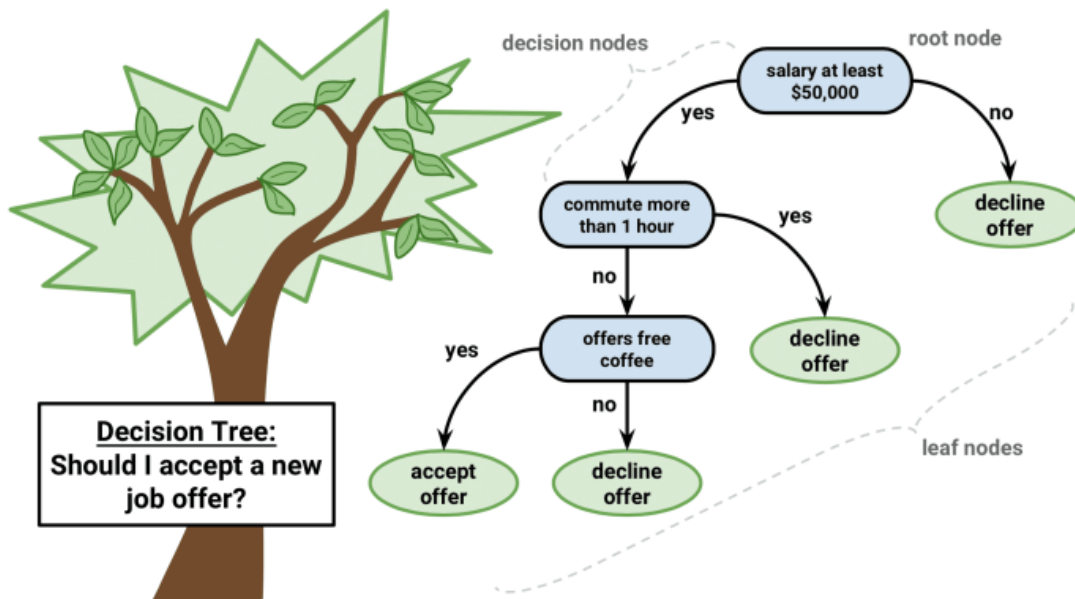

Figure 4.5: Decision trees[25]

Predictions are made by traversing the tree to a leaf node and outputting a class value on that node. Trees learn quickly and make predictions. In addition, they are accurate for a wide range of tasks and require little data training.[25]

Advantages:

- has a high prediction accuracy, on most problems it will be better than linear algorithms; accuracy comparable to boosting accuracy
- practically insensitive to data outliers due to random sampling
- not sensitive to scaling (and generally to any monotonic transformations) of feature values, associated with the choice of random subspaces
- does not require careful setting of parameters, it works well "out of the box". With the help of "tuning" parameters, we can achieve an increase from 0.5 to 3% accuracy, depending on the task and data
- is able to efficiently process data with a large number of features and classes
- handles both continuous and discrete features equally well
- rarely retrained, in practice, adding trees almost always only improves the composition, but on validation, after reaching a certain number of trees, the learning curve reaches the asymptote

- for a random forest, there are methods for evaluating the significance of individual features in the model
- works well with missing data; retains good accuracy if most of the data is missing
- implies the ability to balance the weight of each class on the entire sample, or on a subsample of each tree
- calculates the proximity between pairs of features that can be used in clustering, outlier detection, or (by scaling) give interesting representations of the data
- the capabilities described above can be extended to unlabeled data, which leads to the ability to do clustering and visualization of data, detect outliers
- high parallelizability and scalability.

Disadvantages:

- unlike a single tree, the results of a random forest are more difficult to interpret
- there are no formal conclusions available for assessing the importance of variables
- the algorithm works worse than many linear methods when there are a lot of sparse features in the sample
- a random forest does not know how to extrapolate, in contrast to the same linear regression (but this can be considered a plus, since there will be no extreme values in the event of an outlier hit)
- the algorithm is prone to overfitting on some tasks, especially on noisy data
- for data that includes categorical variables with a different number of levels, random forests are biased in favor of features with a large number of levels: when a feature has many levels, the tree will adapt more precisely to these features, since they can get a higher value of the optimized functional (type of information gain)
- if the data contains groups of correlated features that have a similar significance for labels, then preference is given to small groups over large

4.5.5 Naive Bayesian classifier

Naive Bayes is a simple but surprisingly effective algorithm. The model consists of two types of probabilities, which are calculated using training data: “The probability of each class” and “Conditional probability for each class at each value of x ”.

Once the probability model is calculated, it can be used to predict with new data using Bayes’ theorem. If we have real data, assuming a normal distribution, it is not too difficult to calculate these probabilities.

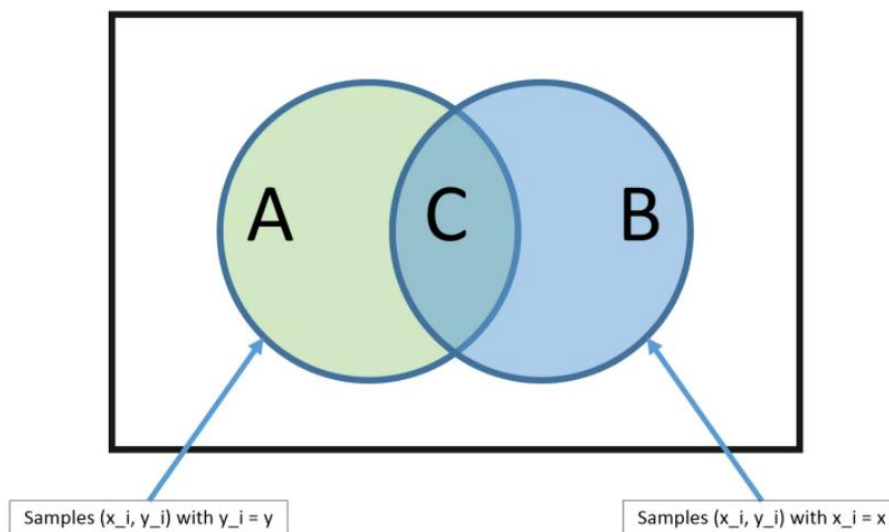

Figure 4.6: Naive Bayesian classifier[25]

Naive Bayes is called naive because the algorithm assumes that every input variable is independent. This is a strong assumption that does not match real data. Nevertheless, this algorithm is very effective for a variety of complex problems like classifying spam or recognizing handwritten numbers.[25]

4.5.6 K-nearest neighbors

Is a very simple and very efficient algorithm. The KNN model is represented by the entire training data set. Prediction for a new point is done by finding K nearest neighbors in the dataset and summing the output variable for those K instances. The only question is how to determine the similarity between the data instances. If all the features have the same scale (e.g., centimeters), the easiest way is to use Euclidean distance, a number that can be calculated from the differences with each input variable.

KNN may require a lot of memory to store all the data, but it will make predictions quickly. Also, the training data can be updated so that the predictions remain accurate over time. The

nearest-neighbor idea may not work well with multidimensional data (many input variables), which will negatively affect the efficiency of the algorithm when solving the problem. This is called the curse of dimensionality. In other words, we should use only the variables that are most important for prediction.[25]

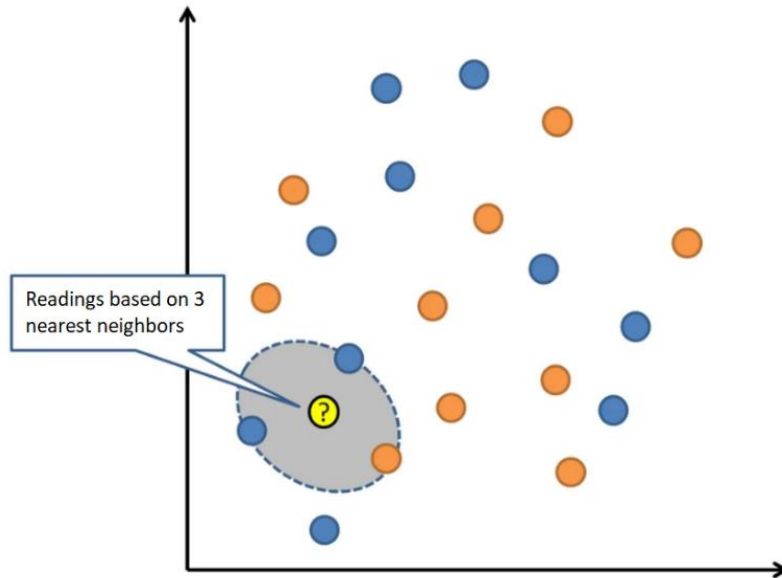

Figure 4.7: K-nearest neighbors[25]

4.5.7 Learning vector quantization (LVQ)

The disadvantage of KNN is that we have to store the whole training dataset. If KNN has shown itself well, then it makes sense to try the LVQ (Learning vector quantization) algorithm, which does not have this disadvantage.

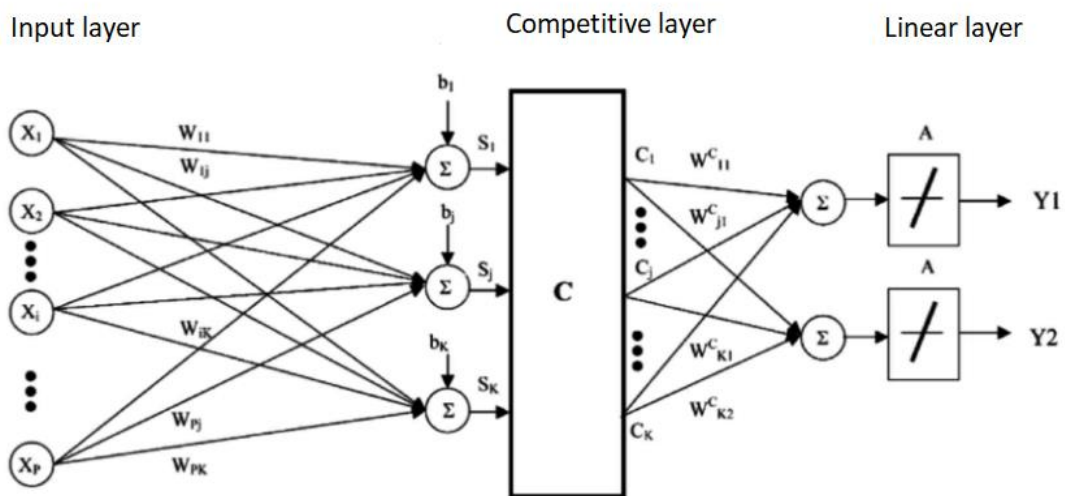

Figure 4.8: Learning vector quantization[25]

LVQ is a set of code vectors. They are chosen randomly in the beginning and adapted over a certain number of iterations to best summarize the entire dataset. After training, these vectors can be used for prediction in the same way as in KNN. The algorithm searches for the nearest neighbor (the best-fitting code vector) by calculating the distance between each code vector and the new data instance. Then a class (or a number in the case of regression) is returned for the best-fitting vector as a prediction. A better result can be achieved if all the data are in the same range, e.g., 0 to 1.[25]

4.5.8 Support-vector machine (SVM)

The reference vector method is probably one of the most popular and discussed machine learning algorithms. A hyperplane is a line separating the space of input variables. In the reference vector method, the hyperplane is chosen to best divide the points in the input variable plane by their class: 0 or 1. In the two-dimensional plane, this can be represented as a line that completely separates points of all classes. During training, the algorithm looks for coefficients that help to better separate the classes by the hyperplane.

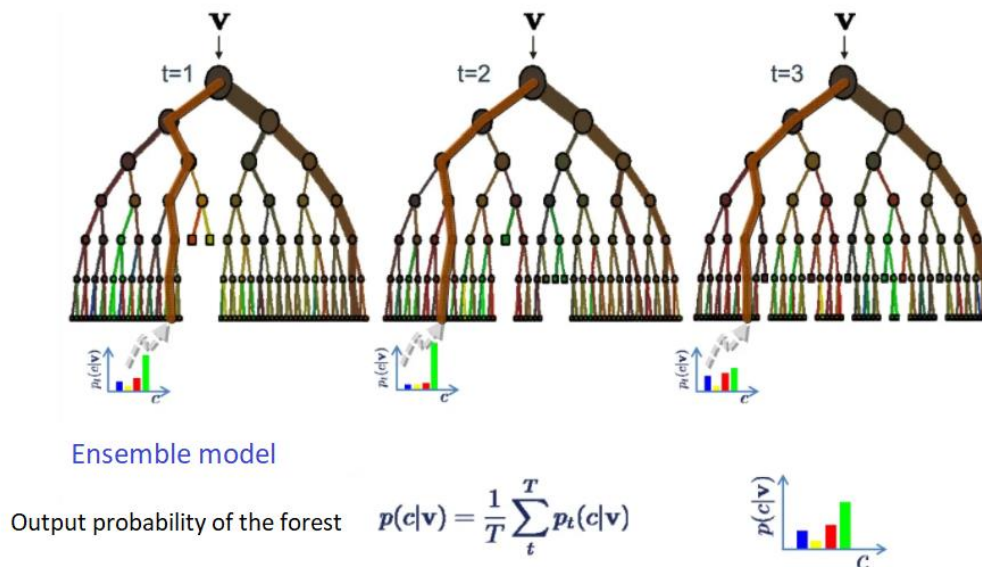

Figure 4.9: Bagging and the Random Forest[25]

In the random forest algorithm, decision trees are constructed for all samples from training data. When the trees are built, random features are selected to create each node. Individually the resulting models are not very accurate, but when they are combined, the quality of the prediction improves considerably. If an algorithm with high variance, such as decision trees, shows a good result on a data, this result can often be improved by applying bagging.[25]

4.5.9 Boosting and AdaBoost

Boosting is a family of ensemble algorithms, the essence of which is to create a strong classifier on the basis of several weak ones. To do this, one model is created first, then another model that tries to correct errors in the first model. Models are added until the training data are perfectly predictable or until the maximum number of models is exceeded. AdaBoost was the first really successful boosting algorithm developed for binary classification. It is the best place to start the introduction to boosting. Modern methods like stochastic gradient binning are based on AdaBoost. AdaBoost is used together with short decision trees. After the first tree is created, its effectiveness on each training object is tested to see how much attention the next tree should give to all objects.

Those data that are hard to predict are given more weight, and those that are easy to predict are given less weight. Models are created one after the other in sequence, and each one updates the weights for the next tree. After all the trees are built, predictions are made for the new data, and the performance of each tree is determined by how accurate it was on the training data. Because this algorithm places great emphasis on correcting model errors, it is important that there are no anomalies in the data.[25]

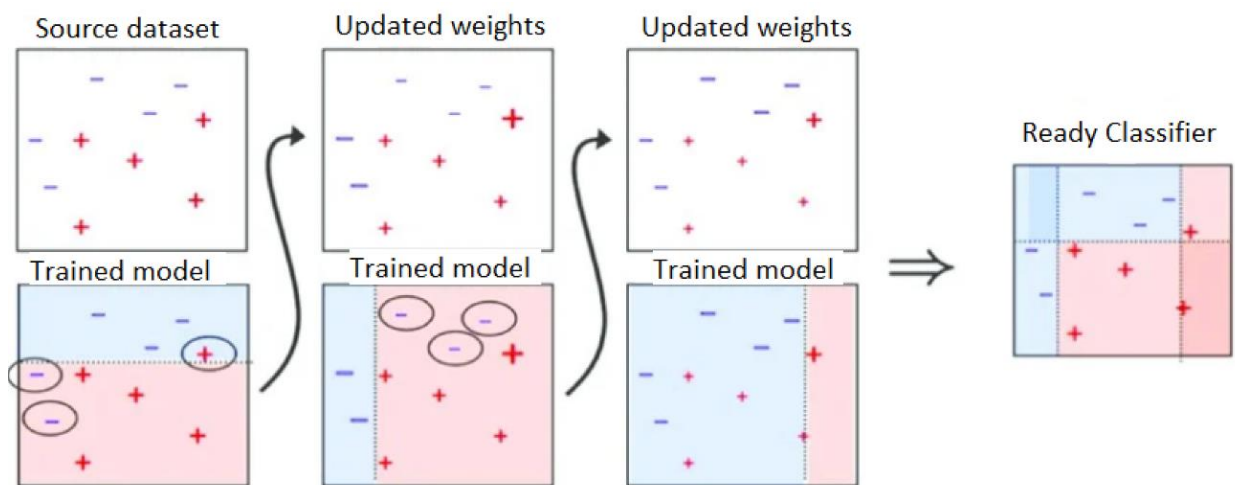

Figure 4.10: Boosting and AdaBoost[25]

5. Case study

5.1 Description

As input data we have two datasets in ".xlsx" format with the names "STUDENT_CHARACTER" (contains information about student activities at the university) and "CREDITATION" (contains information about student mobility activities). The first dataset has values that are important to us, such as: year of admission, school chosen by a student, course chosen by a student, gender, age, the place where the student came from (Concelho and Distrito), degree, type entry, average of the not credit subjects by student, average of the credited subjects, total subjects credited, sum of the subjects credited and final average. And the second data set has important values for us on students in mobility, such as: : year of admission, school chosen by a student, course chosen by a student, country where the student came from, course units chosen by a student, institution where the student came from, average grades, average ECTS.

There are two datasets for research. The first dataset is called "STUDENT_CHARACTER.xlsx" and contains information about the students attending IPB University. The dataset contains three sheets: "1_STUDENT_GENERAL_CHARACTER" (26 columns and 3980 rows), "2_STUDENT_CHARACTER" (14 columns and 27633 rows), "3_CHARACTER_COURSE_UNIT_YEAR" (11 columns and 10227 rows). This dataset contains general information about students enrolled on a full-time basis (year of enrollment, gender, nationality, date of birth, region, course, degree, type of admission and student average grade). The second dataset is called "CREDITATION.xlsx" and contains information about students in mobility. The dataset contains three sheets: "0_CANDIDATURE" (12 columns and 1438 lines), "1_INFORMATION_CREDITED" (15 columns and 8537 lines), "2_BLOCK" (5 columns and 6311 lines). This dataset contains information about students carrying out their activities in mobility (the dataset contains the same values as the first, but also information about the country of mobility and the institution).

My task is to find out what conditions are for certain factors, as well as to determine and analyze the dependence of the values on each other. In order to further, based on the results of

my research, use the data of dependencies visually in the form of graphs and tables for clarity. Namely, create barplots for descriptive analysis, create correlation diagrams and show the correlation index for each dependence of the number, as well as apply machine learning algorithms to the existing dataset, analyze, graph and record the work results for each algorithm in order to choose the best one.

We will analyze the data using the Python programming language and the following libraries which we will need: matplotlib - to visualize the data as two-dimensional graphics; numpy - which supports the mathematical functions we need to calculate; pandas - for data processing and analysis, in particular to work with ".xlsx" extension files; seaborn - to visualize data and highlight their statistical features, in particular to create statistical charts.

When writing code in the python programming language, we will first specify the dataset we need for the specific task of importing data. Then we specify the data we are interested in under a certain graph by listing the names of the columns and solve the given task. After that we get a two-dimensional graph on the output, where the requested information is visually displayed. Then we begin to analyze the obtained results.

5.2 Descriptive analyze

5.2.1 IPB

We will analyze an example of descriptive analysis on the example of the dependence of different values on the year. To begin with, I propose to analyze this method of analysis using the number of students admitted to different schools (Escola Superior Agrária de Bragança – ESA; Escola Superior de Comunicação, Administração e Turismo - EsACT; Escola Superior de Educação de Bragança – ESE; Escola Superior de Saúde de Bragança - ESSa, Escola Superior de Tecnologia e Gestão de Bragança - ESTiG) in different years of entry (2016/2017, 2017/2018, 2018/2019, 2019/2020, 2020/2021) we will analyze the number of students enrolled in different schools by year of entry.

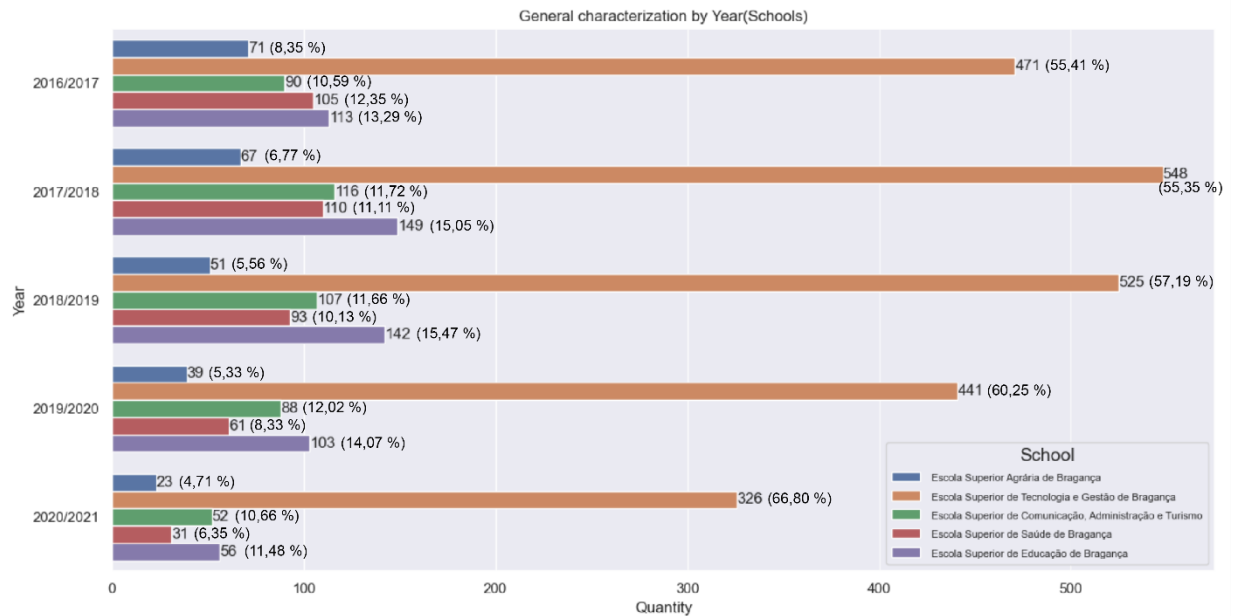

Figure 5.1: General characterization by Year (School)

The bar chart below shows the number and percent of students studying in different schools in different years. The Y-axis represents years, and the X-axis represents the number of students. Next to the scales is the percentage of students in a particular school.

We can compile a list of popularity of schools: 1) ESTiG, 2)ESE, 3) EsACT, 4) ESSa, and 5) ESA. According to the schedule it is clear that the most popular for 5 years was the "ESTiG". As we can see, the ESTiG outperforms all other schools by a wide margin in terms of student enrollment. Whether this function depends on the number of courses the school contains, we will examine in detail in the following examples.

Now we are going to look in detail at the courses belonging to each school and the number of students who have chosen these courses. Schools contain the following courses:

1) ESA:

- Biologia e Biotecnologia
- Ciência e Tecnologia Alimentar
- Enfermagem Veterinária
- Engenharia Agronómica
- Engenharia Alimentar

- Engenharia do Ambiente
- Engenharia Zootécnica
- Cuidados Veterinários
- Produção Agrícola
- Tecnologia Alimentar
- Viticultura e Enologia
- Agroecologia
- Engenharia Biotecnológica
- Gestão de Recursos Florestais
- Qualidade e Segurança Alimentar
- Tecnologias da Ciência Animal

2) EsACT:

- Design de Jogos Digitais
- Gestão e Administração Pública
- Informática e Comunicações
- Marketing
- Multimédia
- Solicitadoria
- Turismo
- Administração e Negócios
- Comunicação Digital
- Informática
- Marketing Turístico

3) ESE:

- Animação e Produção Artística
- Arte e Design
- Desporto
- Educação Ambiental
- Educação Básica
- Educação Social
- Línguas Estrangeiras: Inglês e Espanhol
- Línguas para Relações Internacionais
- Música
- Acompanhamento de Crianças e Jovens
- Desenvolvimento de Produtos Multimédia
- Ilustração e Arte Gráfica
- Serviço Social e Desenvolvimento Comunitário
- Exercício e Saúde
- TIC na Educação e Formação
- Tradução

4) ESSa:

- Ciências Biomédicas Laboratoriais
- Dietética e Nutrição
- Enfermagem
- Enfermagem
- Farmácia

- Gerontologia
- Bioanálises e Controlo
- Gerontologia
- Ciências Aplicadas à Saúde
- Enfermagem Médico-Cirúrgica

5) ESTiG:

- Contabilidade
- Engenharia Biomédica
- Engenharia Civil
- Engenharia de Energias Renováveis
- Engenharia Eletrotécnica e de Computadores
- Engenharia Informática
- Engenharia Mecânica
- Engenharia Química
- Engenharia Química e Biológica
- Gestão
- Gestão
- Gestão de Negócios Internacionais (Curso Europeu)
- Informática de Gestão
- Tecnologia Biomédica
- Tecnologia e Gestão Industrial
- Análises Químicas e Biológicas
- Automação, Robótica e Eletrónica Industrial

- Contabilidade
- Desenvolvimento de Software
- Desenvolvimento de Software e Administração de Sistemas
- Energias Renováveis e Infraestruturas Elétricas e de Telecomunicações
- Energias Renováveis e Instalações Elétricas
- Gestão de Operações e Logística
- Planeamento e Condução de Obra
- Tecnologia Mecânica e Veículos
- Contabilidade e Finanças
- Empreendedorismo e Inovação
- Energias Renováveis e Eficiência Energética
- Engenharia da Construção
- Engenharia Industrial
- Engenharia Química
- Gestão das Organizações
- Informática
- Inovação de Produtos e Processos
- Sistemas de Informação
- Tecnologia Biomédica

Here we can observe that the ESTiG has more courses than the other schools. Also this phenomenon can be explained by the popularity of these areas nowadays in the age of information technology and management.

But for ease of implementation of the data in the graphs, it was decided to visually display only the top 5 courses with the maximum number of students per course for each school.

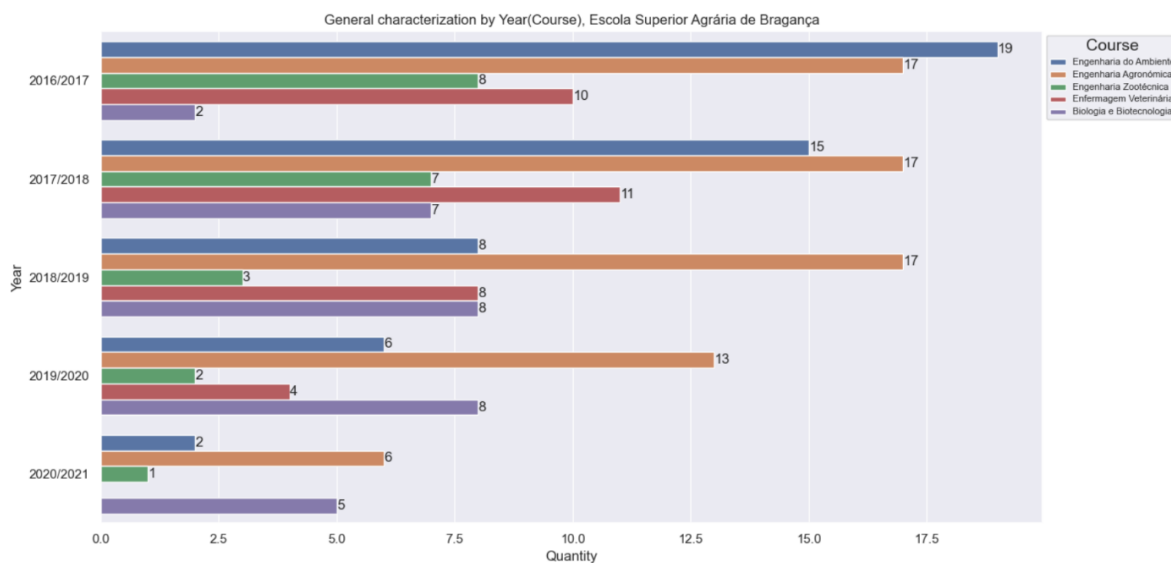

Figure 5.2: General characterization by Year (Course), ESA

The bar chart below shows the number of students studying the top 5 courses for the ESA. The Y-axis represents years, and the X-axis represents the number of students. Top 5 courses for ESA: 1) Engenharia do Ambiente, 2)Engenharia Agronómica, 3) Engenharia Zootécnica, 4) Enfermagem Veterinária, 5) Biologia e Biotecnologia.

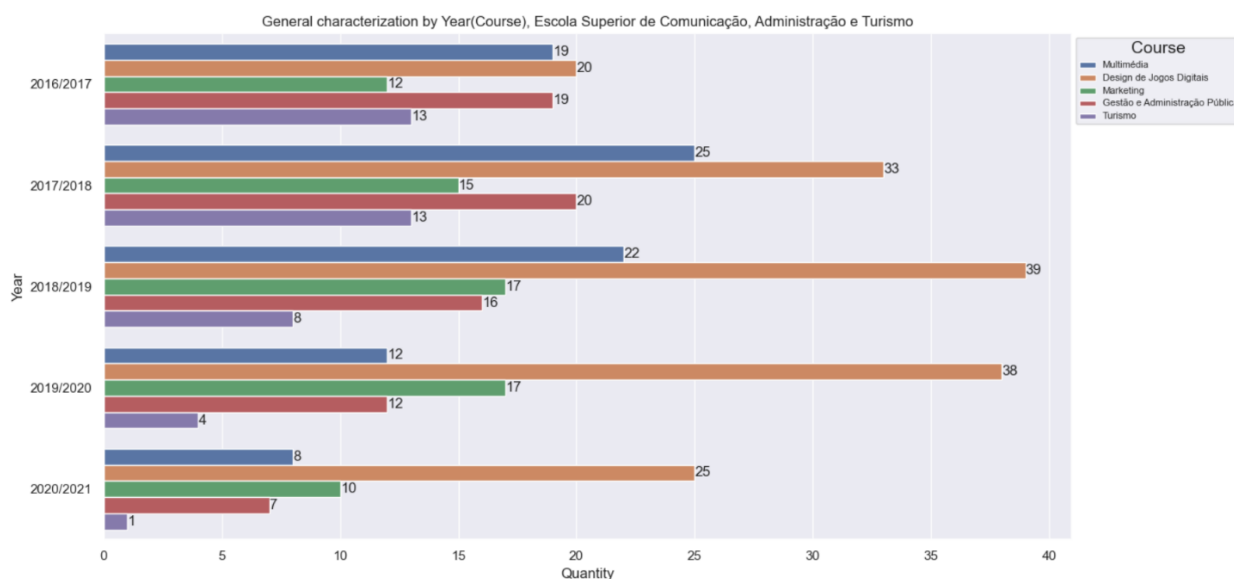

Figure 5.3: General characterization by Year (Course), EsACT

The bar chart below shows the number of students studying the top 5 courses for the EsACT. The Y-axis represents years, and the X-axis represents the number of students. Top 5 courses

for EsACT: 1)Multimédia, 2)Design de Jogos Digitais, 3)Marketing, 4)Gestão e Administração Pública, 5)Turismo.

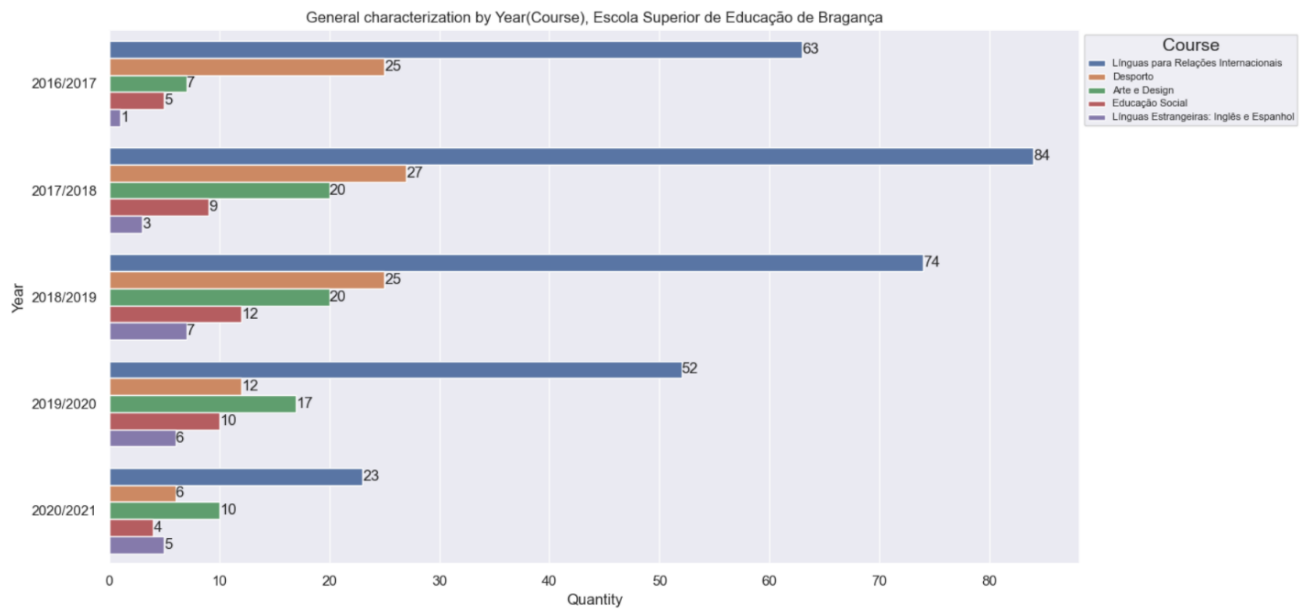

Figure 5.4: General characterization by Year (Course), ESE

The bar chart below shows the number of students studying the top 5 courses for the ESE. The Y-axis represents years, and the X-axis represents the number of students. Top 5 courses for ESE: 1) Línguas para Relações Internacionais, 2) Desporto, 3) Arte e Design, 4) Educação Social, 5) Línguas Estrangeiras: Inglês e Espanhol.

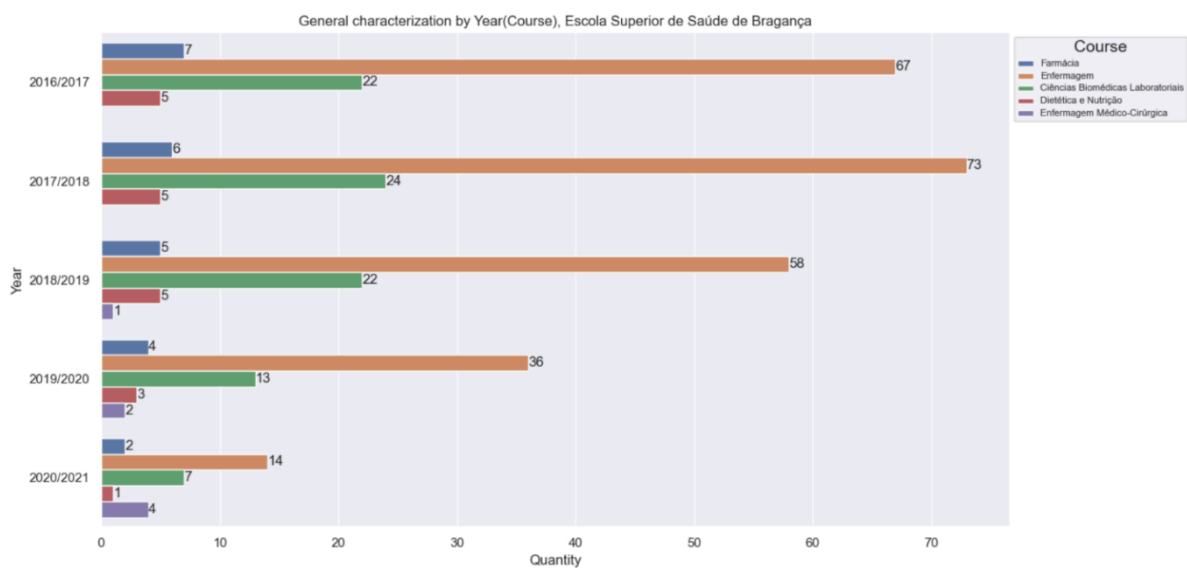

Figure 5.5: General characterization by Year (Course), ESSa

The bar chart below shows the number of students studying the top 5 courses for the ESSa. The Y-axis represents years, and the X-axis represents the number of students. Top 5 courses for ESSa: 1) Farmácia, 2) Enfermagem, 3) Ciências Biomédicas Laboratoriais, 4) Dietética e Nutrição, 5) Enfermagem Médico-Cirúrgica.

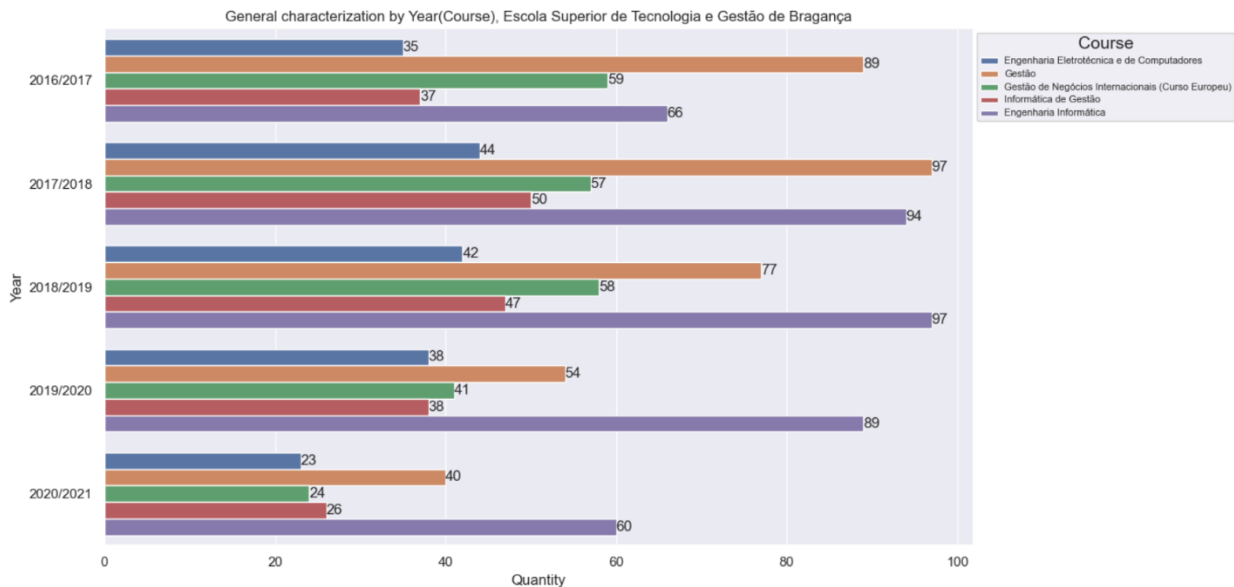

Figure 5.6: General characterization by Year (Course), ESTiG

The bar chart below shows the number of students studying the top 5 courses for the ESTiG. The Y-axis represents years, and the X-axis represents the number of students. Top 5 courses for ESTiG: 1) Engenharia Eletrotécnica e de Computadores, 2) Gestão, 3) Gestão de Negócios Internacionais (Curso Europeu), 4) Informática de Gestão, 5) Engenharia Informática.

According to the available research, we can identify the top 5 most popular areas of university in terms of the number of students for a given period of time:

- 1) Engenharia Informática – 406 students in a given period of time – which is 17,57% of the total number of students who have been absent.
- 2) Gestão – 357 students in a given period of time – which is 15,45% of the total number of students who have been absent.
- 3) Gestão de Negócios Internacionais (Curso Europeu) – 239 students in a given period of time – which is 10,34% of the total number of students who have been absent.

- 4) Informática de Gestão – 198 students in a given period of time – which is 8,57% of the total number of students who have been absent.
- 5) Engenharia Eletrotécnica e de Computadores – 182 students in a given period of time – which is 7,88% of the total number of students who have been absent.

A full study of course data analysis for each school is posted in the annexia.

Let's move on to a graph of the relationship between the year of admission and the gender of the admitted student (male or female).

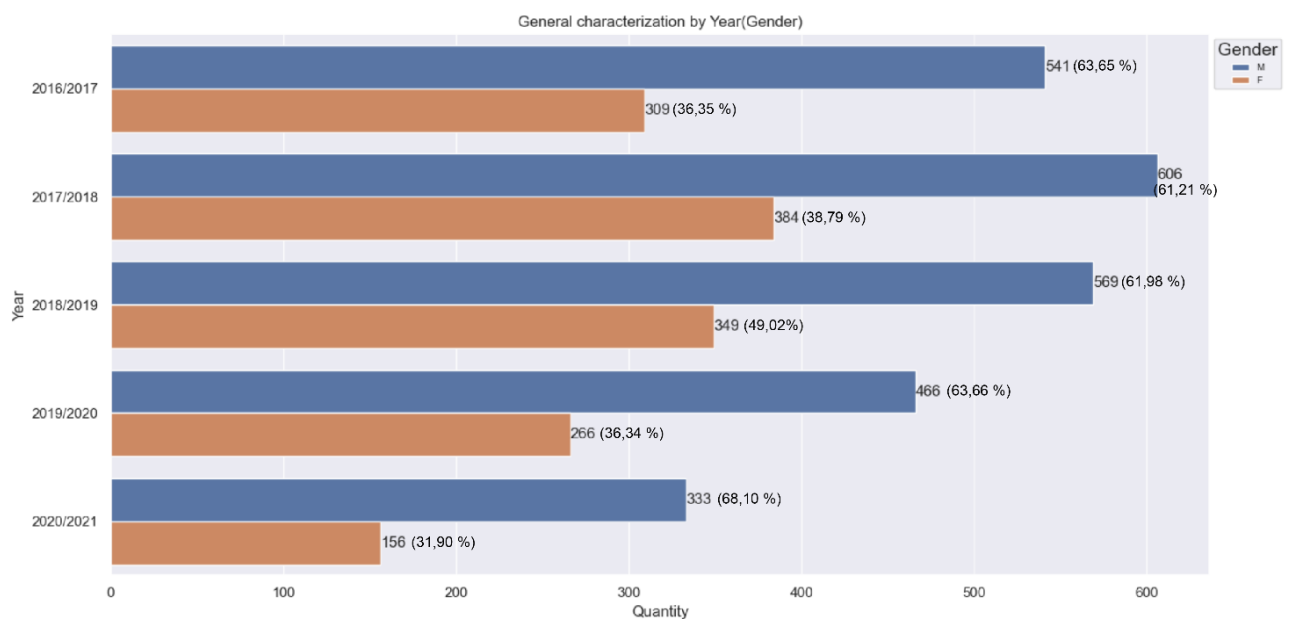

Figure 5.7: General characterization by Year (Gender)

The bar chart below shows the number and percent of students (male and female) studying in different years. The Y-axis represents years, and the X-axis represents the number of students.

From this graph we can conclude that each year the number of male students enrolled in university exceeds the number of female students by about 12,96-36,2 percent.

Let's move on to a graph of the relationship between the year of admission and the age of the admitted student.

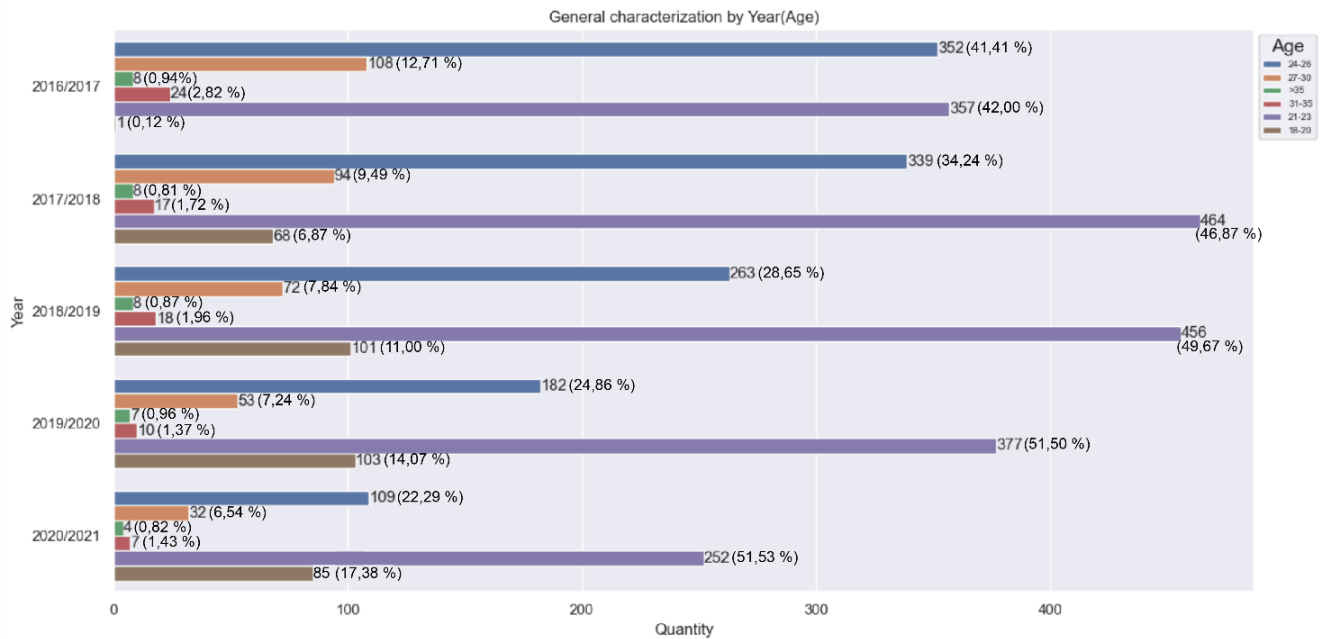

Figure 5.8: General characterization by Year (Age)

The bar chart below shows the number and percent of students of different ages studying in different years. The Y-axis represents years, and the X-axis represents the number of students.

We can use this graph to build a list of student ages according to the number of students in descending order: 1) Students 21-23 years' old; 2) Students 24-26 years' old; 3) Students 27-30 years' old; 4) Students 18-20 years' old; 5) Students 31-35 years' old; 6) Students >35 years' old.

Let's move on to a graph of the relationship between the year of admission and the Concelho&Distrito of the admitted student. The four main cities from which the main flow of students to the Instituto Politécnico de Bragança (Braganca, Vila Real, Lisboa, Porto) comes were chosen.

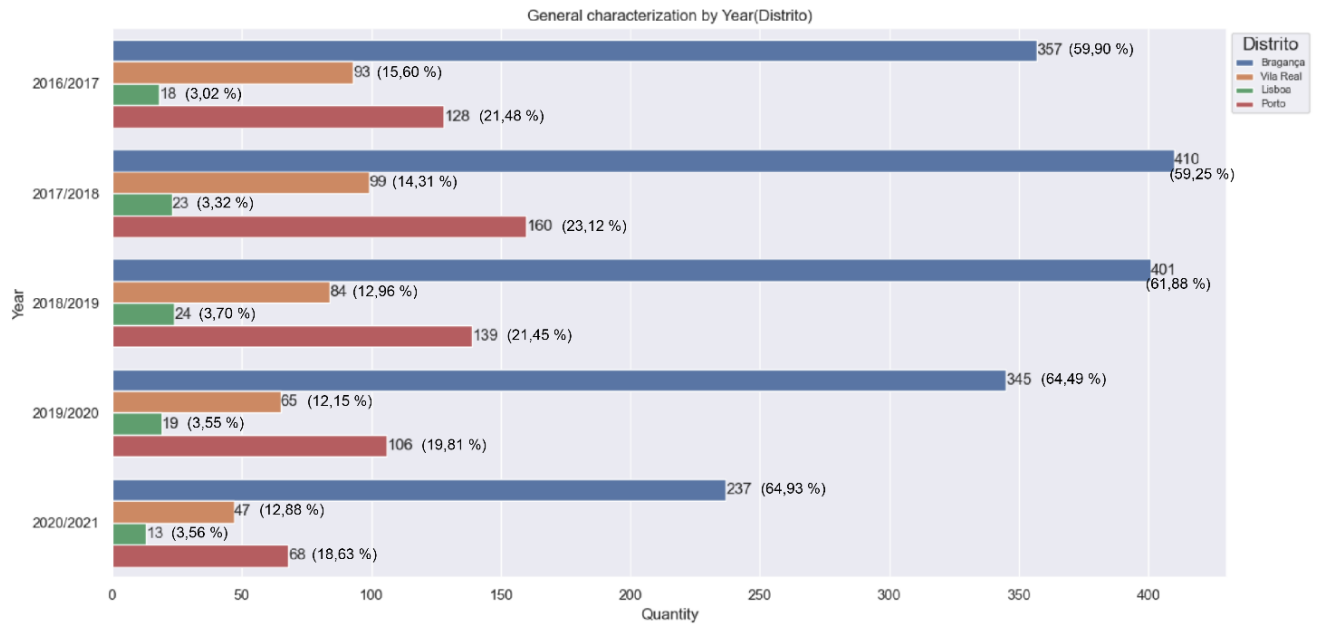

Figure 5.9: General characterization by Year (Distrito)

The bar chart below shows the number and percent of students from different districts in different years. The Y-axis represents years, and the X-axis represents the number of students. The most popular districts are: Bragança, Vila Real, Lisbon and Porto.

Below are the top 5 Concelho from each District.

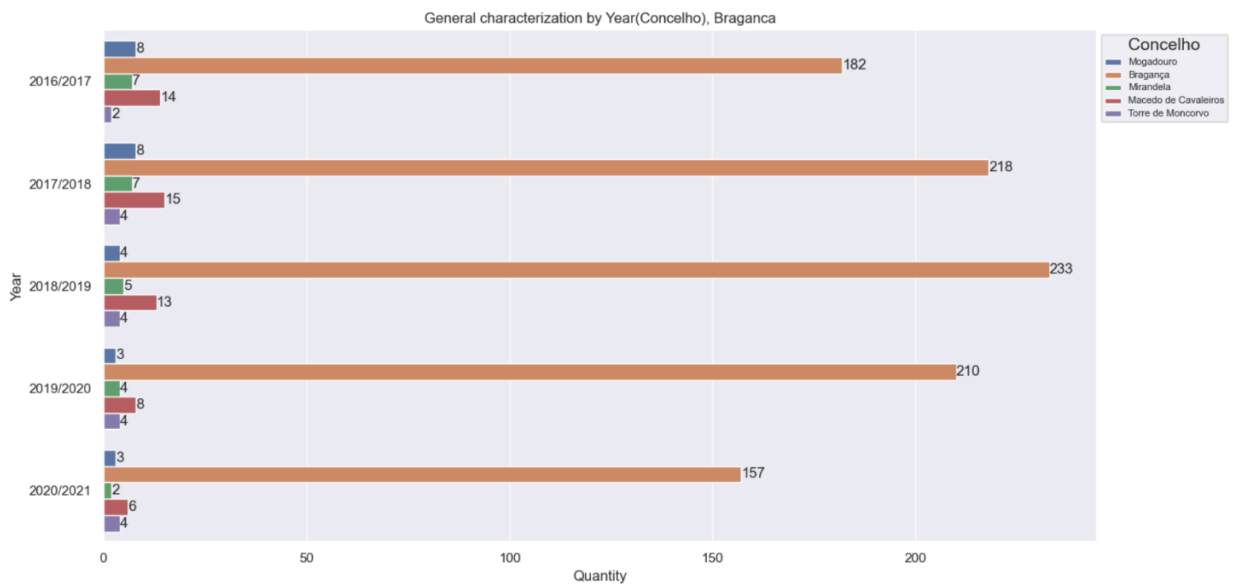

Figure 5.10: General characterization by Year (Concelho), Bragança

The bar chart below shows the number and percent of students from top 5 regions of Braganca districts in different years. The Y-axis represents years, and the X-axis represents the number of students.

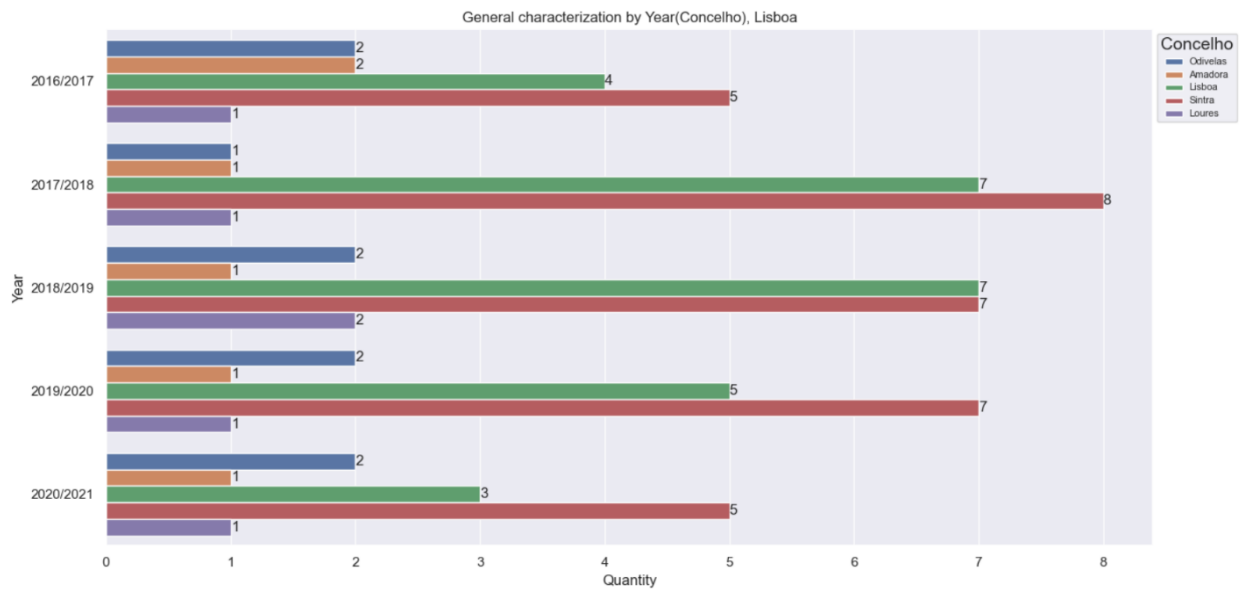

Figure 5.11: General characterization by Year (Concelho), Lisboa

The bar chart below shows the number and percent of students from top 5 regions of Lisbon districts in different years. The Y-axis represents years, and the X-axis represents the number of students.

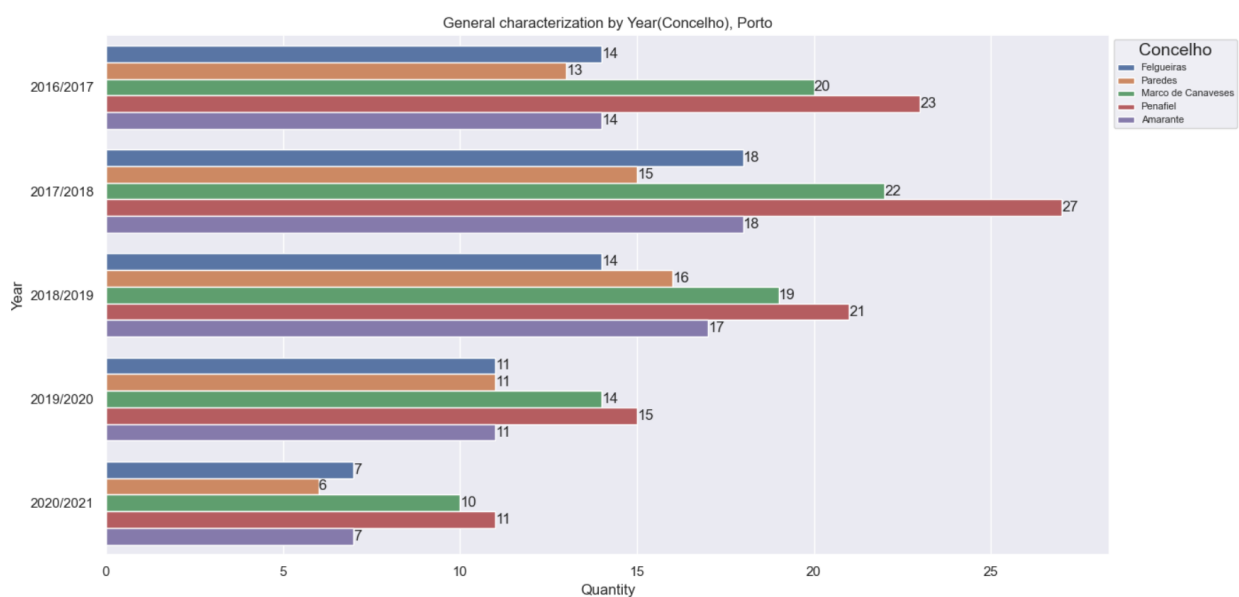

Figure 5.12: General characterization by Year (Concelho), Porto

The bar chart below shows the number and percent of students from top 5 regions of Porto districts in different years. The Y-axis represents years, and the X-axis represents the number of students.

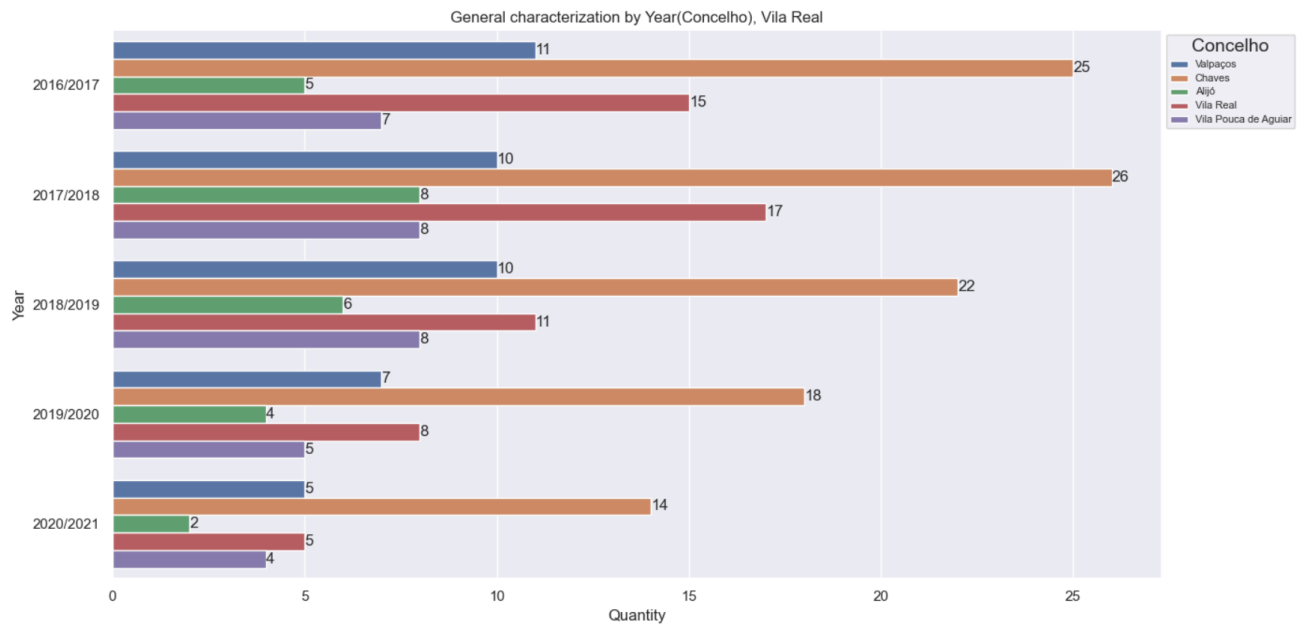

Figure 5.13: General characterization by Year (Concelho), Vila Real

The bar chart below shows the number and percent of students from top 5 regions of Vila Real districts in different years. The Y-axis represents years, and the X-axis represents the number of students. Below is full data for each region in the tables in the annexia.

Let's move on to a graph of the relationship between the year of admission and the Degree of the admitted student.

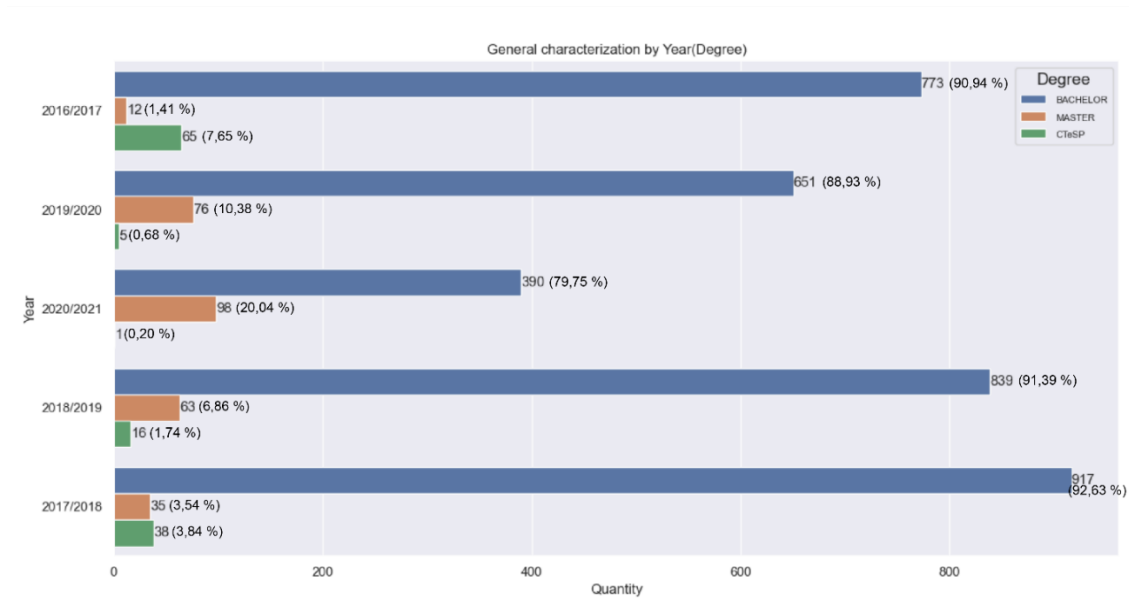

Figure 5.14: General characterization by Year (Degree)

The bar chart below shows the number and percent of students of different degree in different years. The Y-axis represents years, and the X-axis represents the number of students.

The university contains bachelors the most, followed by masters and CTeSP.

Let's move on to a graph of the relationship between the year of admission and the Type Entry of the admitted student.

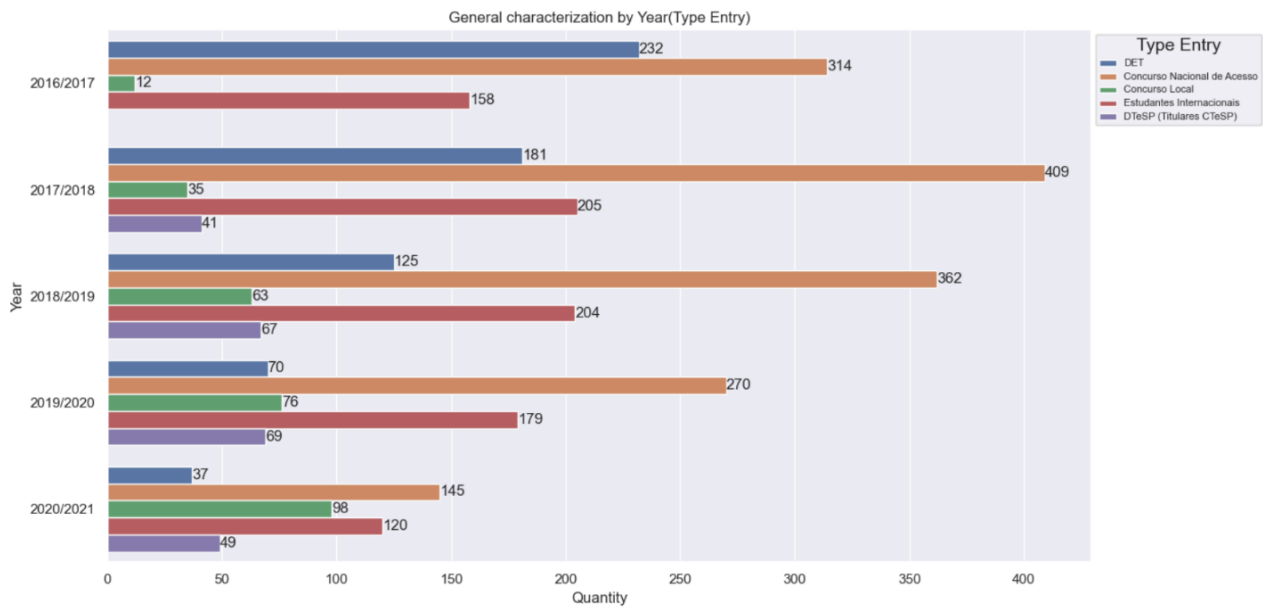

Figure 5.15: General characterization by Year (Type Entry)

The bar chart below shows the number and percent of students from top 5 different type entry in different years. The Y-axis represents years, and the X-axis represents the number of students.

Below is the complete information in the tables in annexia.

Let's move on to a graph of the relationship between the year of admission and the Nationality of the admitted student.

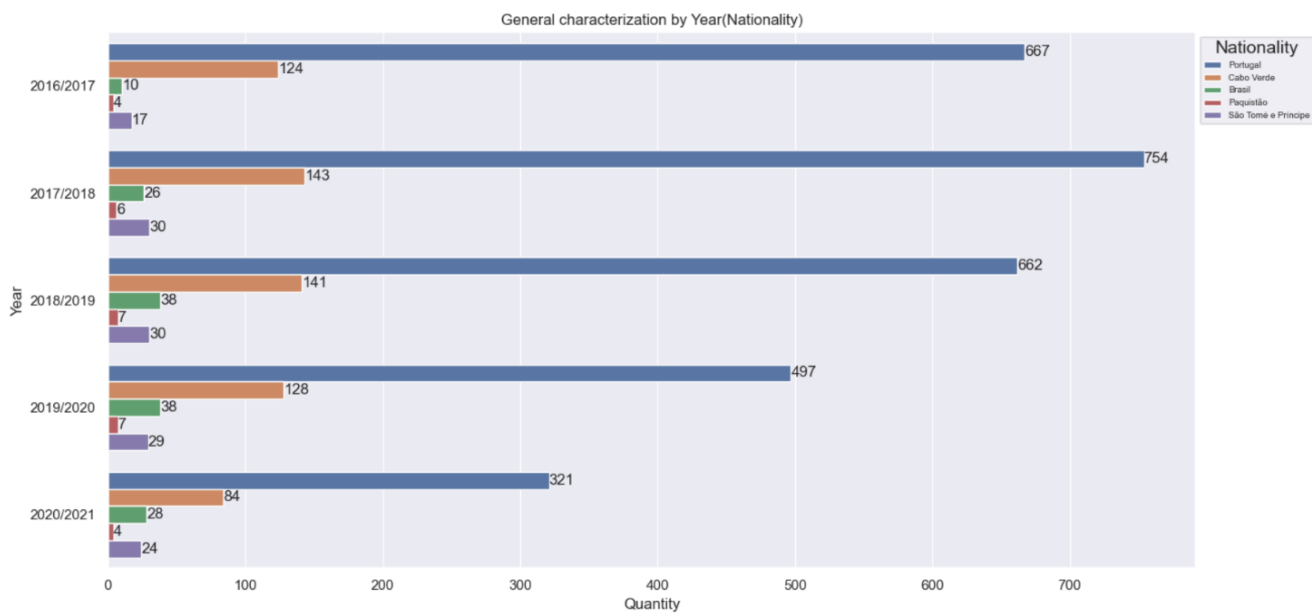

Figure 5.16: General characterization by Year (Nationality)

The bar chart below shows the number and percent of students of top 5 nationalities in different years. The Y-axis represents years, and the X-axis represents the number of students.

Below is the complete information in the tables in annexia.

The next type of schedule differs from the previous ones. It does not reveal the dependence of the variables on the number of students, as was visualized in the previous graphs. The graphs that will be shown visually reflect the numerical, namely the average for each year depending on the task at hand.

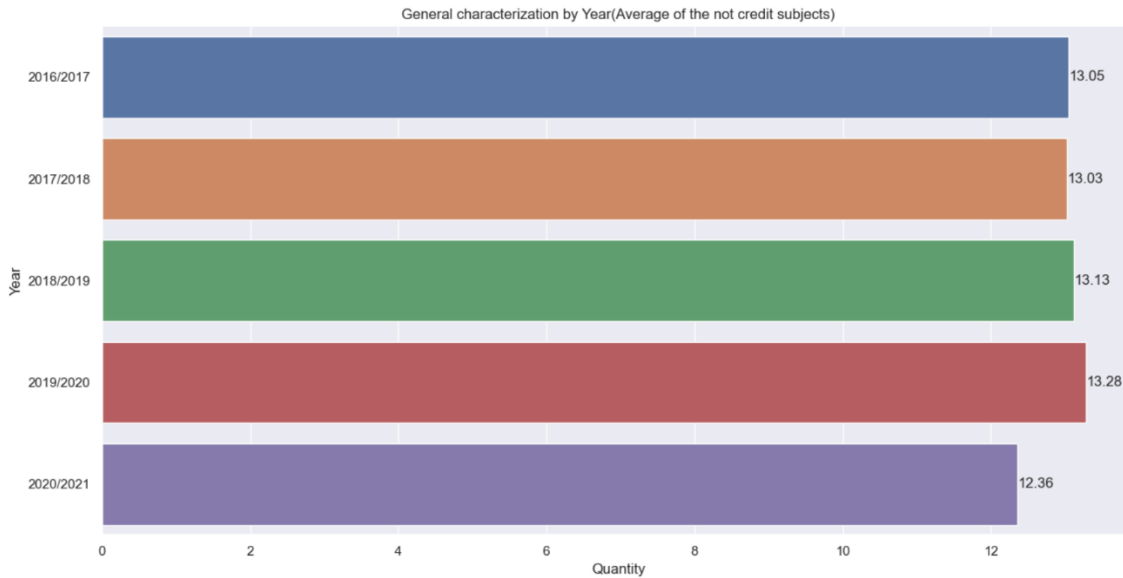

Figure 5.17: General characterization by Year (Average of the not credit subjects)

The bar chart below shows the average number of the not credit subjects in different years. The Y-axis represents years, and the X-axis represents the average value.

The highest average score was in 2019/2020 at 13.28, and the lowest average score was in 2020/2021 at 12.36.

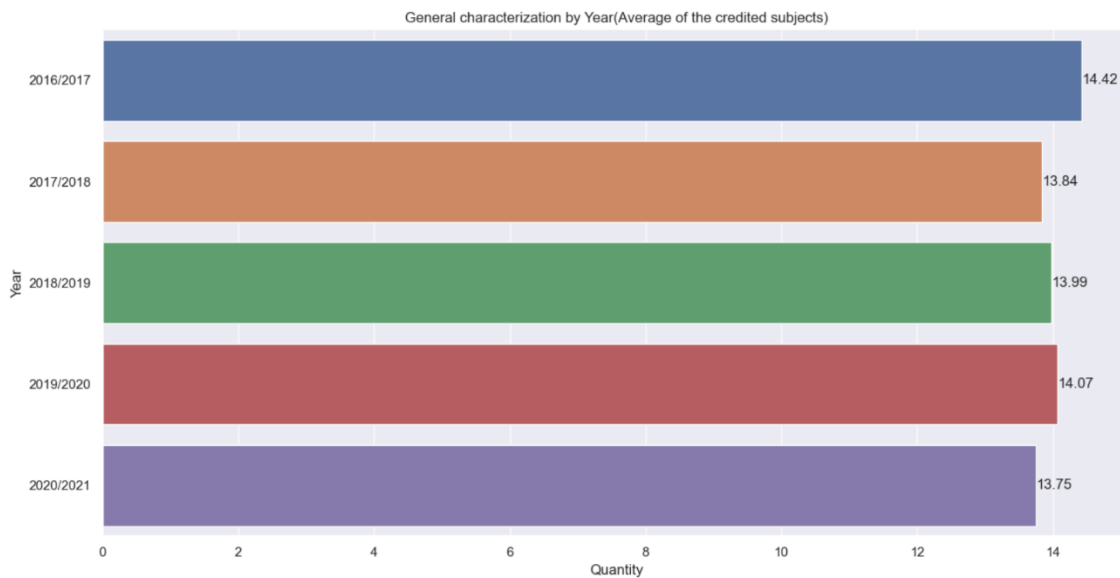

Figure 5.18: General characterization by Year (Average of the credited subjects)

The bar chart below shows the average number of the credited subjects in different years. The Y-axis represents years, and the X-axis represents the average value.

The highest average score was in 2016/2017 at 14.42, and the lowest average score was in 2017/2018 at 13.84.

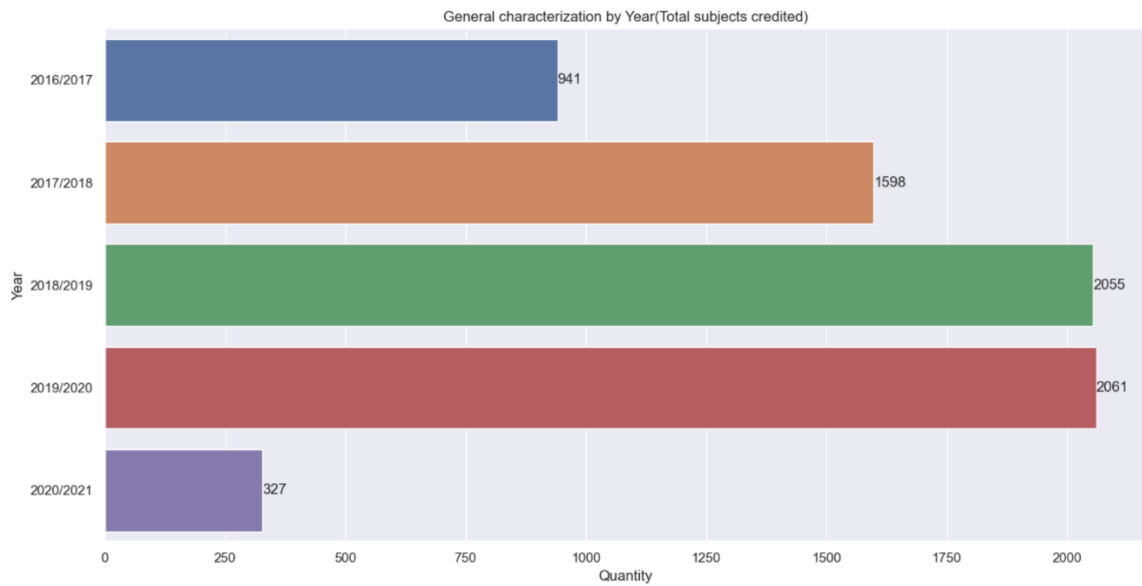

Figure 5.19: General characterization by Year (Total subjects credited)

The bar chart below shows the total subjects credited in different years. The Y-axis represents years, and the X-axis represents the total value.

The highest total score was in 2019/2020 at 2061, and the lowest total score was in 2020/2021 at 327.

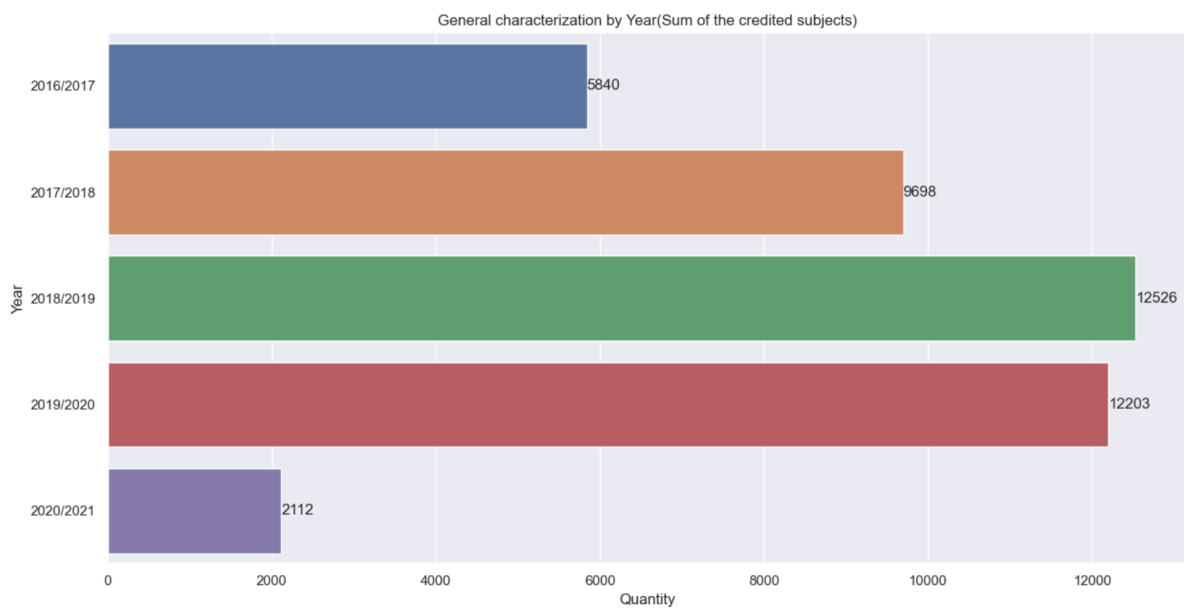

Figure 5.20: General characterization by Year (Sum of the subjects credited)

The bar chart below shows the sum of the subjects credited in different years. The Y-axis represents years, and the X-axis represents the sum value.

The highest sum score was in 2018/2019 at 12526, and the lowest sum score was in 2020/2021 at 2112.

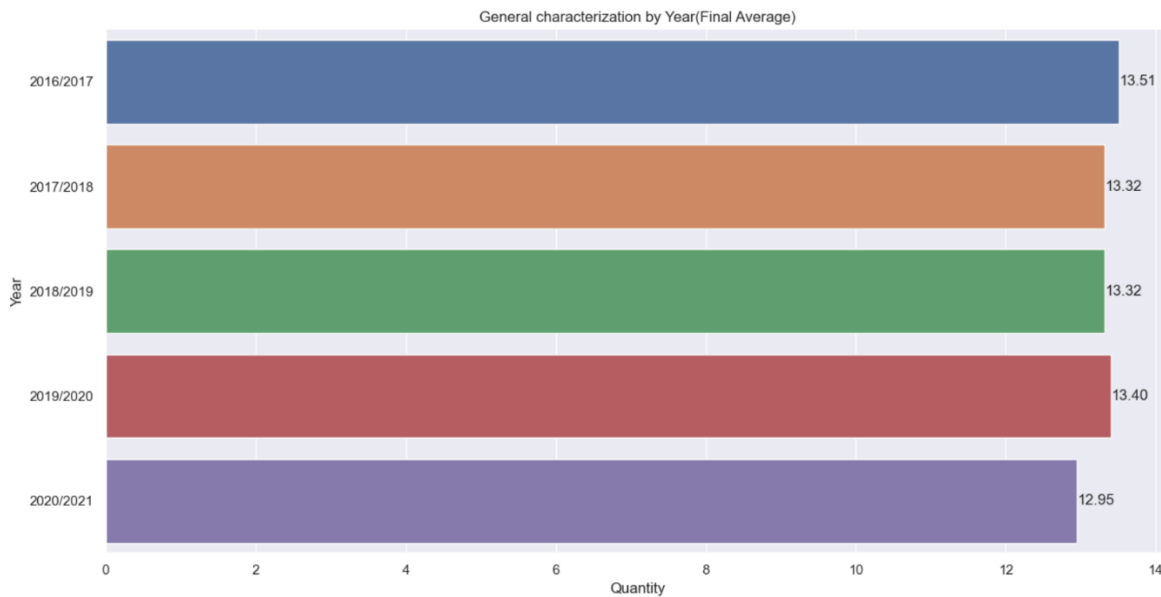

Figure 5.21: General characterization by Year (Final average)

The bar chart below shows the final average number in different years. The Y-axis represents years, and the X-axis represents the average value.

The highest average score was in 2016/2017 at 13.51, and the lowest average score was in 2020/2021 at 12.95.

5.2.2 Mobility

The next chapter of our descriptive analysis focuses on the course units (Entrepreneurship, Internship, Demola Project, Career Planning, Estágio de Iniciação Científica, Inovação Baseda em Desafios, Project Y, Desenvolvimento de Aplicações OutSystems, Desenvolvimento de Aplicações SAP ABAP) from the Instituto Politécnico de Bragança, which took place in mobility.

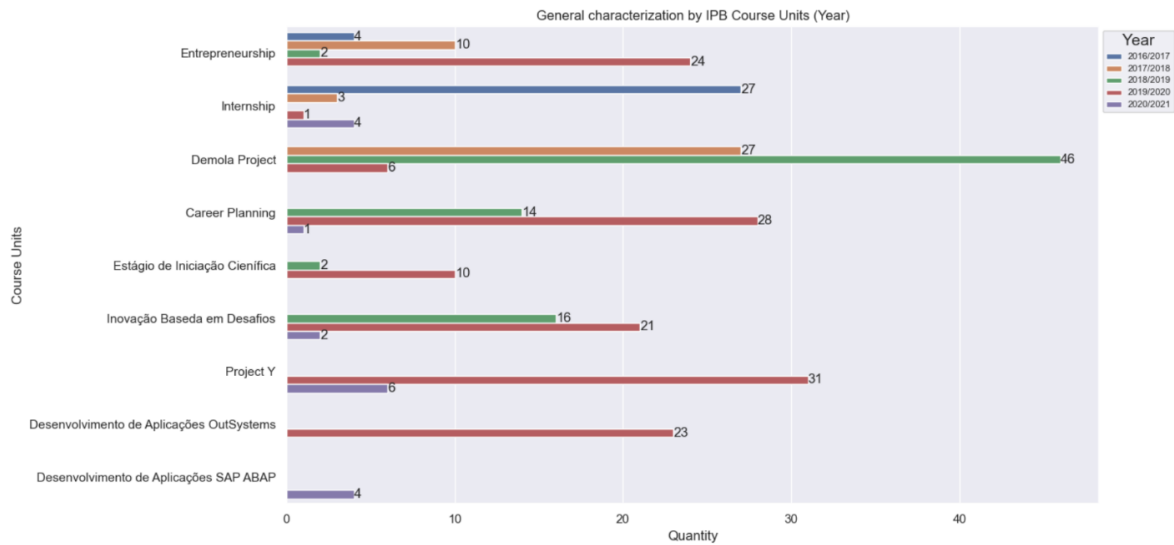

Figure 5.22: General characterization by IPB Course Units (Year)

We can use the above chart to make a descending list by course units by the number of students enrolled in them:

- 1) Demola Project – 79 students in a given period of time – which is 25,32% of the total number of students who have been absent.
- 2) Career Planning – 43 students in a given period of time – which is 13,78% of the total number of students who have been absent.
- 3) Entrepreneurship – 40 students in a given period of time – which is 12,82% of the total number of students who have been absent.
- 4) Inovação Baseda em Desafios – 39 students in a given period of time – which is 12,5% of the total number of students who have been absent.
- 5) Project Y – 37 students in a given period of time – which is 11,86% of the total number of students who have been absent.
- 6) Internship – 35 students in a given period of time – which is 11,22% of the total number of students who have been absent.
- 7) Desenvolvimento de Aplicações OutSystems – 23 students in a given period of time – which is 7,37% of the total number of students who have been absent.

- 8) Estágio de Iniciação Científica – 12 students in a given period of time – which is 3,85% of the total number of students who have been absent.
- 9) Desenvolvimento de Aplicações SAP ABAP – 4 students in a given period of time – which is 1,28% of the total number of students who have been absent.

A full study of the data analysis of course units in mobility is attached as an annexia.

This part focuses on the remaining course units in mobility. In the next steps we will examine and analyze in detail the number of students in mobility in relation to course, country, and institution. For the following graph, the top countries were selected according to the year students entered for a better visual representation.

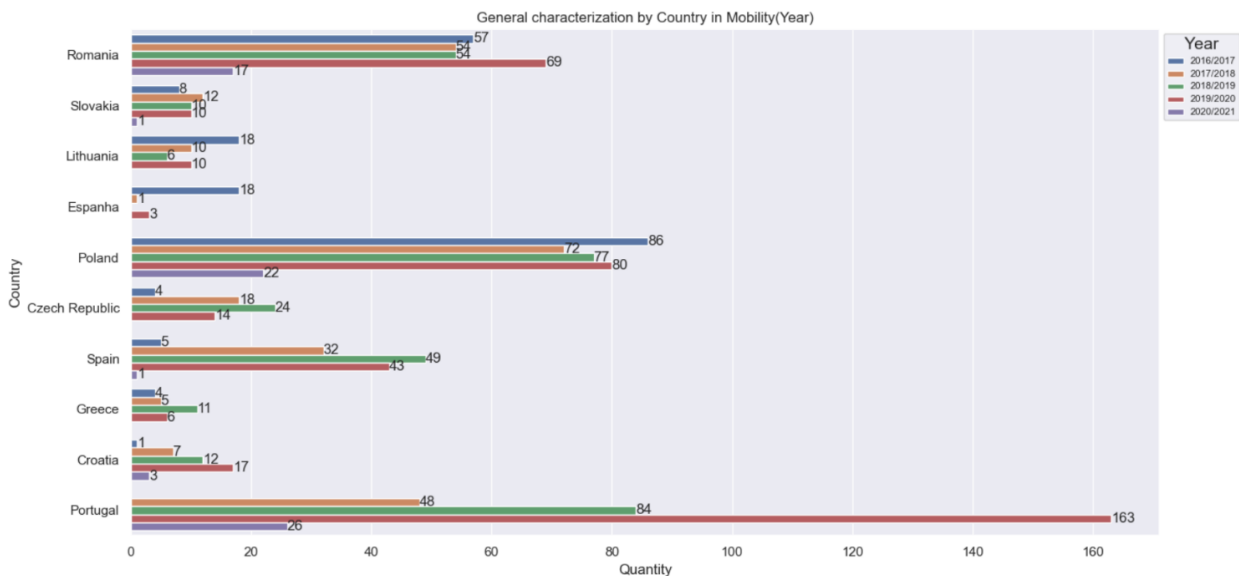

Figure 5.23: General characterization by Country in Mobility(Total)

The bar chart below shows the count of students in Mobility. The Y-axis represents years, and the X-axis represents the count of students.

For the following graph, the top countries were selected according to the year students entered for a better visual representation.

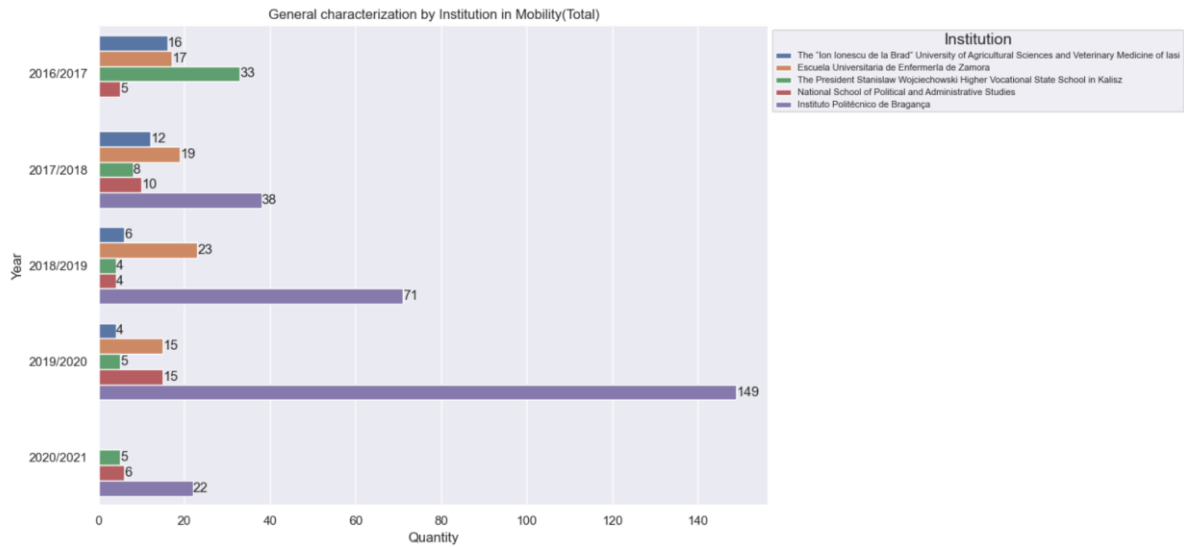

Figure 5.24: General characterization by Country in Mobility(Total)

The bar chart below shows the count of students in Mobility. The Y-axis represents years, and the X-axis represents the count of students.

For the following graph, the top Institutions were selected according to the year students entered for a better visual representation.

5.3 Correlation diagrams

Correlation matrices are tables detailing the correlation coefficients between different variables in an easily visualized manner. A correlation matrix provides a sort of index where one can see how strong the correlation is among different variables. The correlation coefficients in this matrix fall within a range of -1 to 1 where -1 is a perfectly negative correlation, 0 is no correlation, and 1 is a perfectly positive correlation.

Both matplotlib and seaborn offer invaluable tools at generating these visualizations. Let's generate a correlation matrix heatmap using seaborn to visually represent our correlations. The code:

```
import matplotlib.pyplot as plt
```

```
import numpy as np
```

```
from numpy.lib.function_base import average
```

```
import pandas as pd
```

```
import seaborn as sns
```

```
from seaborn.categorical import barplot
```

```
df = pd.read_excel("Name_of_the_file")
```

```
plt.figure(figsize=(12,10), dpi= 80)
```

```
sns.heatmap(df.corr(),xticklabels=df.corr().columns,  
yticklabels=df.corr().columns,cmap='RdYlGn',center=0, annot=True)
```

```
plt.title('Creditation', fontsize=22)
```

```
plt.xticks(fontsize=12)
```

```
plt.yticks(fontsize=12)
```

```
plt.show()
```

5.3.1 Part of the Student Characteristics

To begin, I suggest plotting a complete correlation chart with all the values from the dataset about students carrying out their activities at the university.

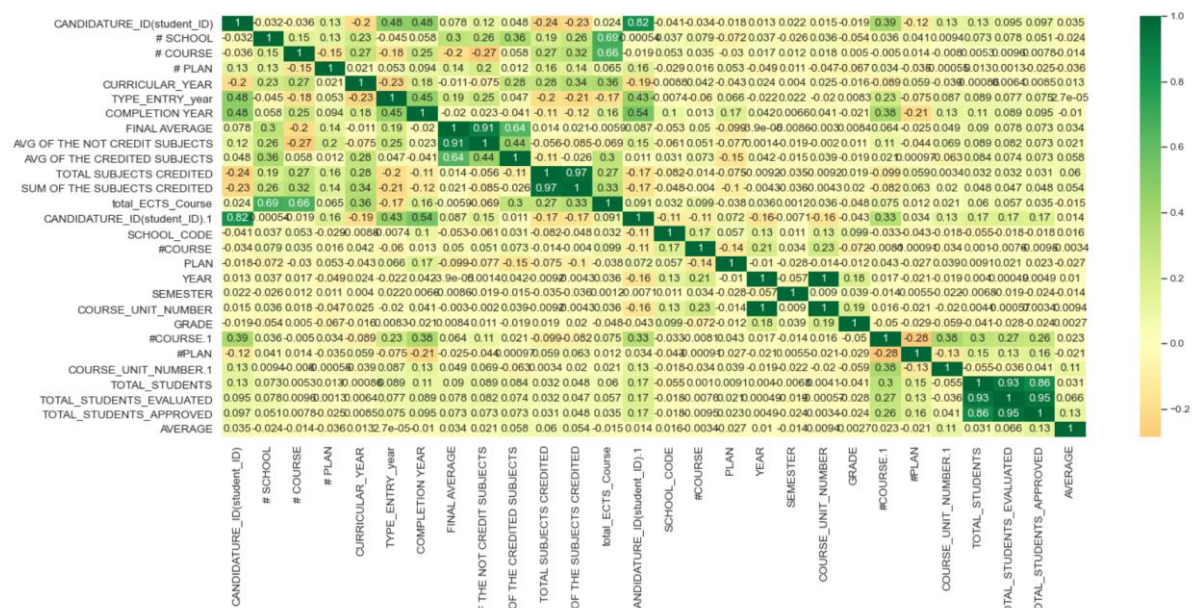

Figure 5.26: Full Correlation of “Student Characters” dataset.

From this thermal correlation diagram, we can make several hypotheses about the relationships between the values, which I find interesting.

For example, the correlation index between TOTAL_STUDENTS_EVALUATED and AVERAGE is 0.066, and the correlation index between TOTAL_STUDENTS_APPROVED and AVERAGE is 0.13.

TOTAL_STUDENTS_EVALUATED & AVERAGE = 0.066

TOTAL_STUDENTS_APPROVED & AVERAGE = 0.13

Following the conclusion that the correlation index between admitted students and their average grade is higher than the correlation index between the total number of graded students and their average grade, we can hypothesize that admitted students, in this situation, have a higher average grade than the total number of graded students, which is logical from my point of view.

I also think it makes sense to pay attention to the high correlation index between such values as CURRICULAR_YEAR and total_ECTS_course, which is 0.36.

CURRICULAR_YEAR & total_ECTS_course = 0.36

From this we can hypothesize that the greater the number of years a student has been mobile at university, the more ECTS points he/she will be able to obtain at the end of his/her academic and practical activities.

The next interesting relationship between the variables is the relationship between FINAL AVERAGE and AVG OF THE NOT CREDIT SUBJECTS, which is 0.91, which is a very high correlation index. And also the relationship between FINAL AVERAGE and AVG OF THE CREDITED SUBJECTS, which has a correlation index of 0.64.

FINAL AVERAGE & AVG OF THE NOT CREDIT SUBJECTS = 0.91

FINAL AVERAGE & AVG OF THE CREDITED SUBJECTS = 0.64

From this we can hypothesize that the average final grade of a student is influenced more by items that were obtained prior to mobility at the university than by those that were assessed in mobility.

The next interesting relationship I suggest is the relationship between variables such as AVG OF THE NOT CREDIT SUBJECTS and CURRICULAR_YEAR, where the correlation index is 0.075. And also between the dependencies AVG OF THE CREDITED SUBJECTS and CURRICULAR_YEAR, where the correlation index is 0.28.

AVG OF THE NOT CREDIT SUBJECTS & CURRICULAR_YEAR = 0.075

AVG OF THE CREDITED SUBJECTS & CURRICULAR_YEAR = 0.28

So with the second relationship, the heat plot correlation index is greater than the first, hence we can hypothesize that the more time a student spends in mobility, the more IPB-accredited courses will affect their average final grade.

The next interesting relationship I propose to consider is between such variables as AVG OF THE NOT CREDIT SUBJECTS and total_ECTS_course, where the correlation index is -0.069. And also between the dependencies AVG OF THE CREDITED SUBJECTS and total_ECTS_course, where the correlation index is 0.3.

AVG OF THE NOT CREDIT SUBJECTS & total_ECTS_course = -0.069

AVG OF THE CREDITED SUBJECTS & total_ECTS_course = 0.3

Hence, we can hypothesize that the final ECTS scores are more influenced by the subjects accredited at the university than those outside of it.

And the last interesting correlation I found in this correlation heat chart, I suggest to consider the relationship between such variables as TOTAL SUBJECTS CREDITED and total_ECTS_course, where the correlation index is 0.27. And also between the dependent SUM OF THE SUBJECTS CREDITED and total_ECTS_course, where the correlation index is 0.33.

TOTAL SUBJECTS CREDITED & total_ECTS_course = 0.27

SUM OF THE SUBJECTS CREDITED & total_ECTS_course = 0.33

From this we can hypothesize that the number of ECTS points is more proportional to the number of points a student can get for the subjects he or she has acquired than to the number of these very subjects. In other words, it is not the number of courses taken that is important, but the high value of the average grades that a student received for those university courses that he/she had taken before.

Let's take a closer look at the individual sections:

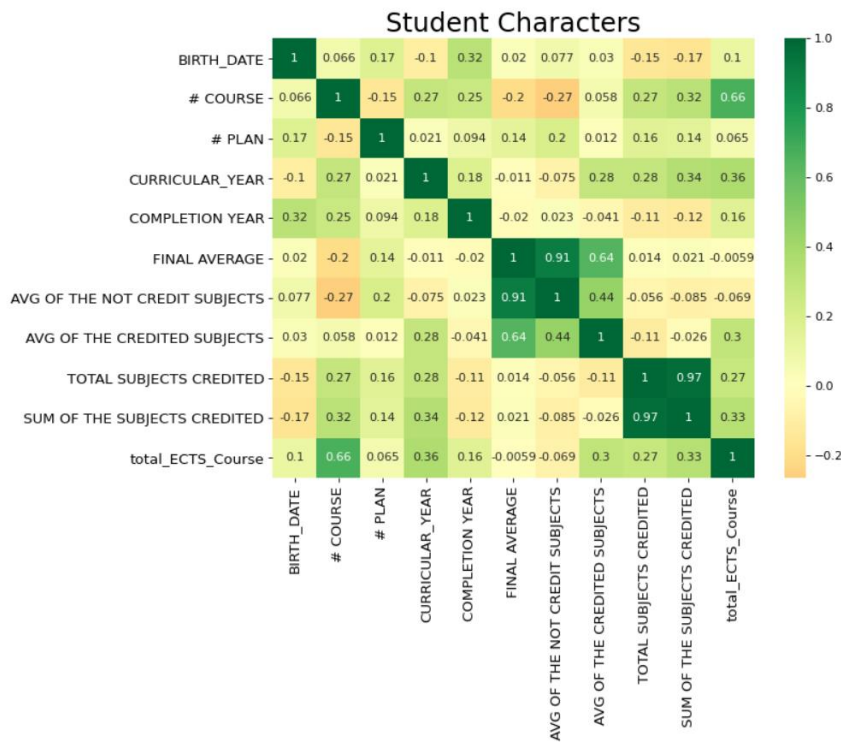

Figure 5.27: Correlation of “Student Characters” dataset.

Consider a correlation chart on a selected data set that contains a general characteristic of students enrolled in IPB. Recall that the higher the correlation index is located toward one, the higher the correlation between the two parameters. For example, the values of #COURSE have a relatively high correlation with TOTAL SUBJECTS CREDITED (0.27), SUM OF THE SUBJECTS CREDITED (0.32), and total_ECTS_Course (0.66), which implies that a student's course selection has a dependency on their academic performance. Also, the CURRICULAR_YEAR parameter has a small correlation with the parameters TOTAL SUBJECTS CREDITED (0.28), SUM OF THE SUBJECTS CREDITED (0.34), total_ECTS_Course (0.36) and AVERAGE_OF_THE_CREDITED_SUBJECTS(0.28).

At the same time, the lack of correlation between two quantities does not mean that there is no relationship between them. For example, the dependence can have a complex nonlinear nature, which correlation does not reveal.

As can be seen, the parameters of the SUM_OF_THE_SUBJECTS_CREDITED, AVG_OF_THE_NOT_CREDIT_SUBJECTS have a strong correlation. (correlation coefficient > 0.7). Consequently, in order for the model to work correctly it is necessary to remove these values from these parameters.

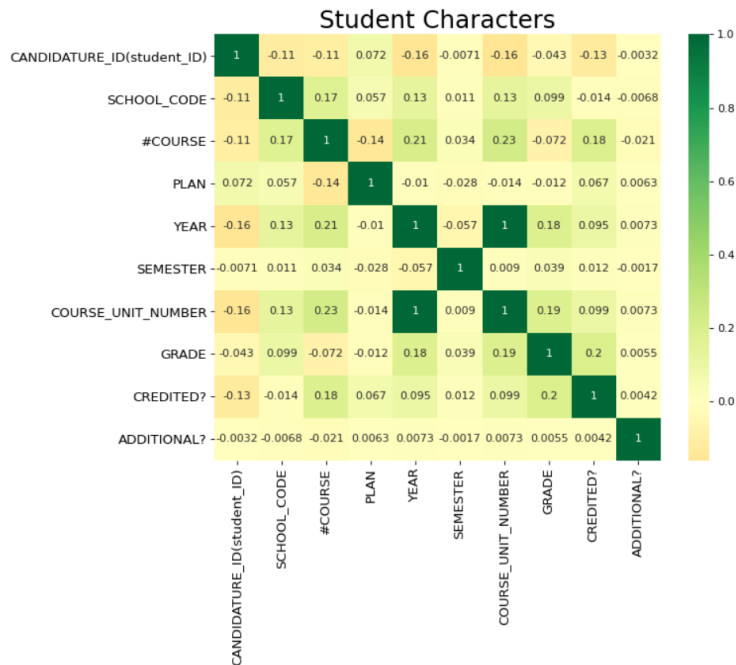

Figure 5.28: Correlation of “Student Characters” dataset.

Consider the correlation diagram for the selected dataset, which contains a different characteristic of students enrolled in IPB. For example, #COURSE values have a relatively high correlation with YEAR values (0.21), suggesting that the choice of courses depended on the year of enrollment, possibly related to the different demand for professional skills. Or the GRADE parameter has a relatively high correlation with the COURSE_UNIT_NUMBER parameter (0.19), suggesting that students have staggered performance on the same course units.

As can be seen, the parameters of COURSE UNIT NUMBER have a strong correlation. (correlation coefficient > 0.7). Consequently, in order for the model to work correctly it is necessary to remove these values from these parameters.

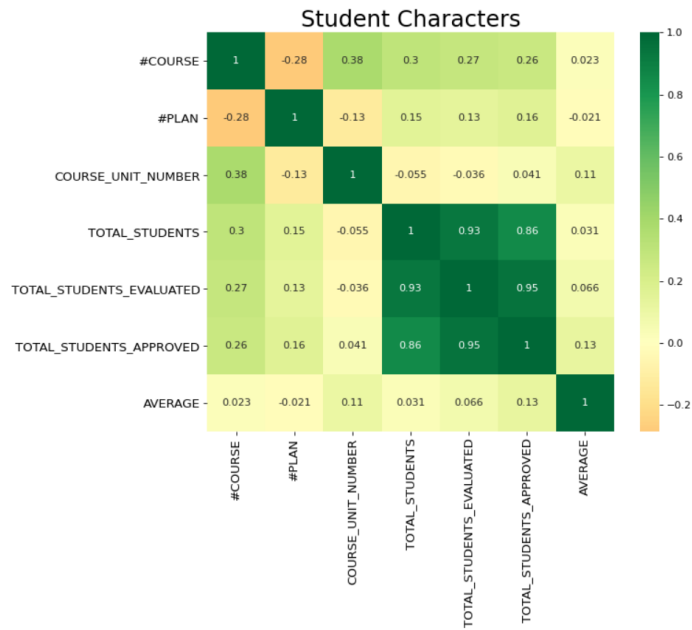

Figure 5.29: Correlation of “Student Characters” dataset.

Consider the last correlation diagram for the selected dataset, which contains information about the characteristics of units' courses by year. For example, the values of #COURSE have a relatively high correlation with the values of TOTAL_STUDENTS_EVALUATED (0.27) and TOTAL_STUDENTS_APPROVED (0.26). This suggests that the number of students evaluated and approved by course has stagnated in this segment in a proportional way depending on the course.

As can be seen, the parameters of TOTAL_STUDENTS_EVALUATED and TOTAL_STUDENTS_APPROVED have a strong correlation. (correlation coefficient > 0.7). Consequently, in order for the model to work correctly it is necessary to remove these values from these parameters.

5.3.2 Part of the Mobility

To begin, I suggest plotting a complete correlation chart with all the values from the dataset about students carrying out their activities in a mobility.

This dataset, which contains information about mobility students, is not as large as the previous one, so I propose to analyze it in its entirety. However, in this dataset the parameters that are directly related to each other are highly correlated: #SCHOOL and #COURSE, #SCHOOL and #PLAN, #SCHOOL and BLOCK_NUMBER, #PLAN and CANDIDATURE_ID. These dependencies do not need to be explained.

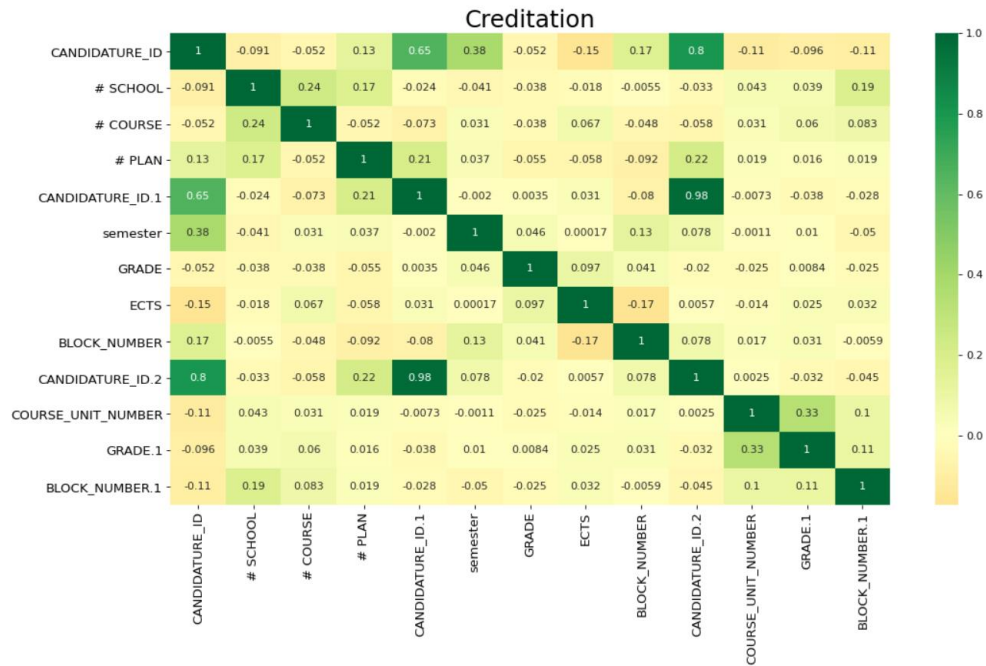

Figure 5.30: Full Correlation of “Creditation” dataset.

5.4 Predictive analyze

For the predictive analysis, I chose three popular machine learning algorithms: Linear Regression, Ridge Regression, and Random Forest. My choice was due to the fact that these algorithms seemed to me the most interesting for a particular problem. In the scientific articles that I read, these algorithms were most often used to analyze datasets for similar problems. This factor finally determined the choice of machine learning algorithms for my work, because their principles and work were the most clear to me.

For the predictive analysis, it was decided to conduct it by the number of students and the course units from the IPB. The purpose of this study is to compare and analyze different machine learning algorithms for predicting the number of students by course units. For each algorithm, a graph will be built to graphically show the actual information about how many students have chosen a particular course unit for mobility at IPB over a certain period of time. The blue graph will show the section of actual information over the past time, the orange graph will show the section that we will try to predict and the green broken line graph will show the result that the machine learning algorithm has produced. Each will be analyzed, conclusions

drawn, and the root mean squared error calculated, showing how close the predicted result is to the actual real information.

	2016/2017	2017/2018	2018/2019	2019/2020	2020/2021
Entrepreneurship	4	10	2	24	0
Internship	27	3	0	1	4
Demola Project	0	27	46	6	0
Career Planning	0	0	14	28	1
Estágio de Iniciação Científica	0	0	2	10	0
Inovação Baseda em Desafios	0	0	16	21	2
Project Y	0	0	0	31	6
Desenvolvimento de Aplicações OutSystems	0	0	0	23	0
Desenvolvimento de Aplicações SAP ABAP	0	0	0	0	4

Figure 5.34: Up-to-date information on students who have taken a unit course in IPB mobility

For this task, we will create a separate dataset, which will contain only the values: the name of the course, as well as the time intervals in which the students entered. This dataset will be in ".csv" format and will look as follows. The separator between the values will be the "@" symbol, as this symbol is not used in unit course names. This is necessary to avoid errors when executing the program code. Data output from machine learning algorithms will be implemented through the console.

As we can see from the table, the number of students increased each year for each unit course until 2020/2021. In that year the number of students went down drastically for each course unit. So why did this happen? At this point, the situation with the coronavirus in the world and in Europe in particular has had a huge impact. The introduction of vaccination passports, increased infection rates, and border closures have had a detrimental effect on this factor. The introduction of lockdowns in countries with large numbers of people infected with coronavirus has been a barrier to many students participating in international mobility. This explains the dramatic drop in students per unit course. Further results in the predictive analysis also take this fact into account. However, the results for next years' predictions may also be inaccurate because of the virus. Various mutations of the virus and the emergence of new strains (quite recently scientists discovered a new strain of the virus, Omicron) may have a negative impact on the new results for next years prediction, as the current situation with the coronavirus is unpredictable at the moment.

	A
1	subject@2016/2017@2017/2018@2018/2019@2019/2020@2020/2021
2	"Natura 2000" European Ecological Network@1@0@0@0@0
3	"Why Did The Romans Wear Togas?" Aspects of ancient Rome ab urbe condita to the end of the republic - Seminar@0@0@1@0@0
4	[Practical English - Advanced Communication Skills@0@0@0@1@0
5	[Practical English - Reading Comprehension & Writing@0@0@0@0@0
6	Practical English - Practical Grammar@0@0@0@0@0
7	2D Animation@2@2@0@1@1
8	2D Background Design@2@1@0@1@0
9	2D Character Design@3@2@0@1@0
10	3D@0@0@0@0@1
11	3D Advanced Creation@0@2@0@0@1
12	3D Animation@4@0@1@1@1
13	3D Character Modelling@0@0@1@0@1
14	3D Modelling and Texturing I@0@1@0@0@1
15	3D Modelling and Texturing I@2@4@0@0@1
16	3D Modelling and Texturing II@2@4@1@0@1
17	3D Modelling and Texturing III@2@4@1@0@1
18	3D Modelling and Texturing I@0@0@0@1@1
19	3D Technics@0@0@0@1@1
20	A arte de falar em público@0@0@2@0@0

Figure 5.35: Up-to-date information on students who have taken a unit course in IPB mobility

5.4.1 Linear Regression

Linear regression is a model that explains the dependence of one variable Y on another variable or several other variables X with a linear dependence function. It does not know how to select the best attributes to predict. We have to select them manually. Because of this, the model can become over-trained, leading to much worse results than expected on a test data set.

Let's use the ready-made linear regression model from the sklearn library:

Import Linear Regression

```
from sklearn.linear_model import LinearRegression
```

Let's split our database into a training and a test dataset to check how well the model performs.

We do this with the train_test_split function from the sklearn library:

```
from sklearn.model_selection import train_test_split
X_train, X_test, Y_train, Y_test = train_test_split(X, Y, test_size=0.4, random_state=2)
```

Now we can "train" the model using the fit() method:

```
model = LinearRegression().fit(X_train, Y_train)
```

To check the quality of the work done, let's calculate the Mean squared error (MSE). In statistics, the mean squared error or mean squared deviation (MSD) of an estimator (of a procedure for estimating an unobserved quantity) measures the average of the squares of the errors - that is, the average squared difference between the estimated values and the actual value. MSE is a risk function, corresponding to the expected value of the squared error loss. The MSE is a measure of the quality of an estimator. As it is derived from the square of Euclidean distance, it is always a positive value with the error decreasing as the error approaches zero.

Obtaining the mean squared error for a linear regression

```
prediction_test = model.predict(X_test)
```

```
from sklearn import metrics
```

```
print('mse=',metrics.mean_squared_error(Y_test, prediction_test))
```

We ended up with $MSE = 0.4177749178178838$, which is a pretty good result.

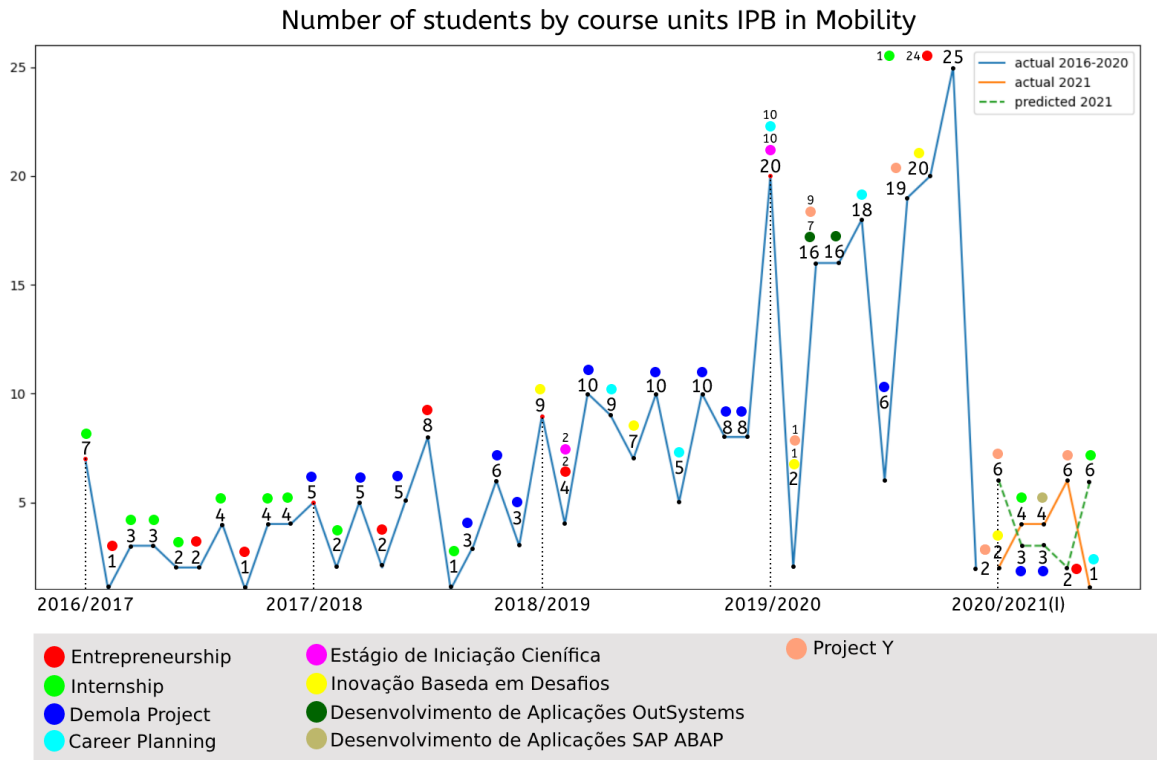

Figure 5.36: Result of Linear Regression

Although the means squared error showed a relatively good result, looking at the graph we see a clear deviation. First, the number of students known to us for the first semester of 2020/2021 was 17 students. The graph predicted us an enrollment of 20 students. We know from current information that there were 4 students in Internship, 1 student in Career Planning, 2 students in Inovação Baseda em Desafios, 6 students in Project Y, and 4 students in Desenvolvimento de Aplicações SAP ABAP during this time period. Although the algorithm was able to predict the approximate number of students (there were 17 and predicted 20), it could not predict the names of the units' course, and simply chose the most repetitive ones. This algorithm did not do a very good job.

5.4.2 Ridge Regression

Let's move on to the next model, Ridge Regression. This is one of the methods that are used to deal with data overshoot. It is also a linear model. The principle of the model is that the linear regression coefficients remain as small as possible, but the quality of the prediction does not deteriorate.

Let's use the ready-made ridge regression model from the sklearn library:

Import Ridge Regression

```
from sklearn.linear_model import Ridge
```

Let's split our database into a training and a test dataset to check how well the model performs.

We do this with the `train_test_split` function from the `sklearn` library:

```
from sklearn.model_selection import train_test_split
```

```
X_train, X_test, Y_train, Y_test = train_test_split(X, Y, test_size=0.4, random_state=2)
```

Now we can "train" the model using the `fit()` method:

```
model = Ridge()
```

```
model.fit(X_train, Y_train)
```

```
prediction_test = model.predict(X_test)
```

```
from sklearn import metrics
```

```
print('mse=', metrics.mean_squared_error(Y_test, prediction_test))
```

We ended up with $MSE = 0.4177719718577941$. The values were almost equal compared to the usual linear regression. This means that the first model was not over trained.

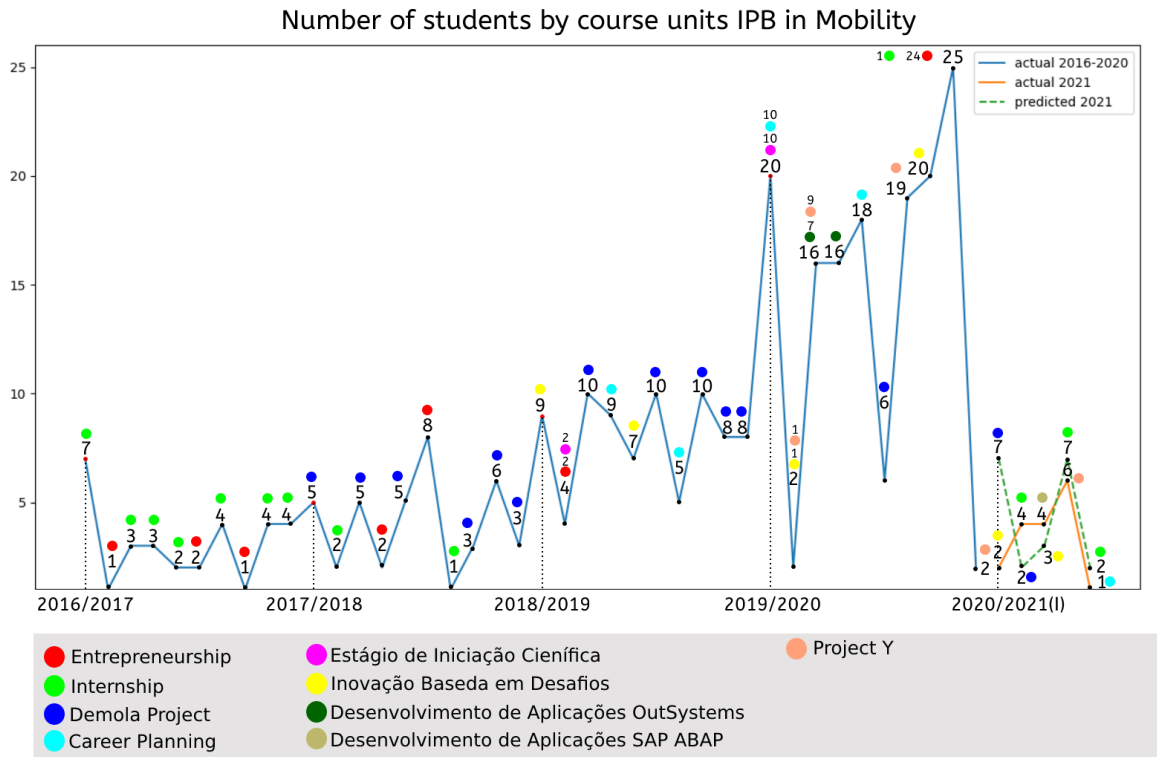

Figure 5.37: Result of Ridge Regression

The situation is similar with the ridge regression algorithm. It predicted us the number of students as 21, which is close to the actual information. The coincidence of the course units is small. In my opinion, this linear algorithm also does not fit our task.

5.4.3 Random Forest

Let us consider the last model of regression analysis "Random Forest". It is no longer linear and works on a different principle. Random forest is a supervised learning algorithm. The "forest" it builds, is an ensemble of decision trees, usually trained with the "bagging" method. The general idea of the bagging method is that a combination of learning models increases the overall result.

Let's use the ready-made random forest model from the sklearn library:

```
from sklearn.ensemble import RandomForestRegressor
```

Let's split our database into a training and a test dataset to check how well the model performs.

We do this with the train_test_split function from the sklearn library:

```
from sklearn.model_selection import train_test_split
X_train, X_test, Y_train, Y_test = train_test_split(X, Y, test_size=0.4, random_state=2)
```

Now we can "train" the model using the fit() method:

```
model = RandomForestRegressor(n_estimators=100, random_state=2)

model.fit(X_train, Y_train)

prediction_test = model.predict(X_test)

from sklearn import metrics

print('mse=', metrics.mean_squared_error(Y_test, prediction_test))
```

We ended up with $MSE = 0.3282981933215518$. The random forest showed a better result for our given situation, because its mean squared error is more close to zero than that of the regressions. So the predicted data on the graph will be more close to the actual values. Random Forest performed many times better than linear regressions, but that does not mean that this model will always outperform the others.

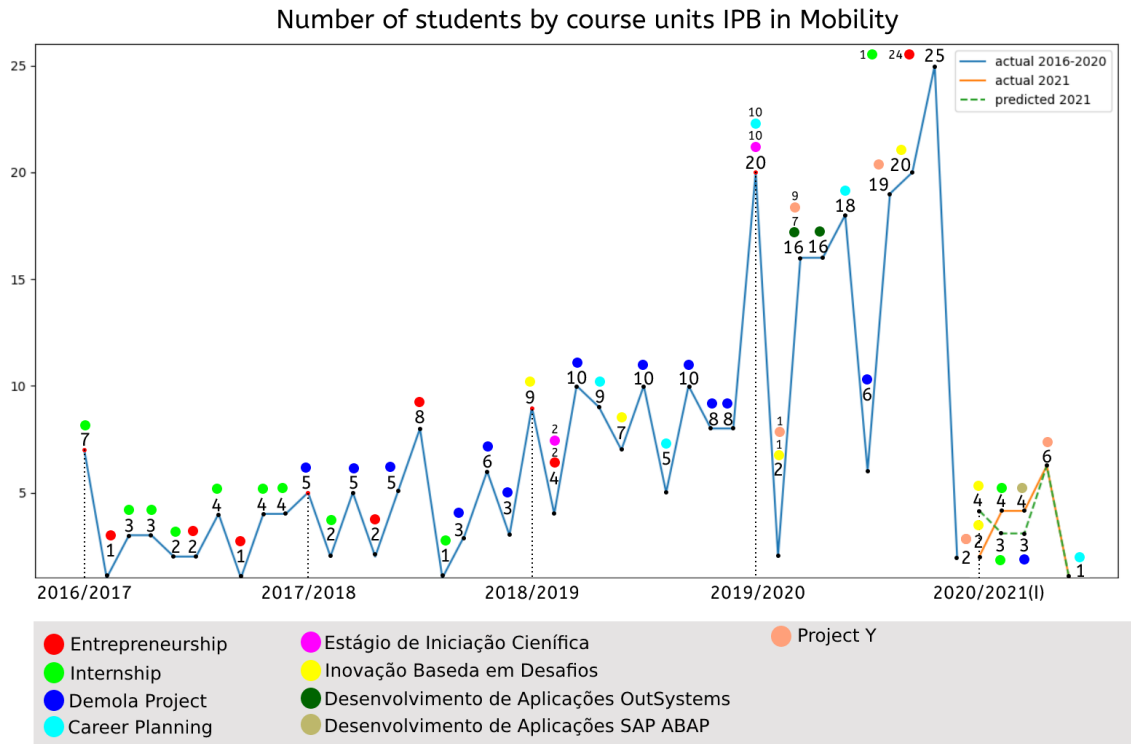

Figure 5.38: Result of Random Forest

Random Forest had the best results from this list. First, it was able to predict the exact number of students at 17, which is the same as the actual information. Second, it was able to predict three unit courses (Inovação Baseda em Desafios, Internship and Project Y), which is also consistent with current information. We can conclude that the random forest algorithm performed better than the previous two linear machine learning algorithms and is the most suitable for predicting values for this problem.

Now that we have decided on a machine learning algorithm, I suggest we use it and try to predict the number of students by unit course at an IPB university. To do this we will need to modify the program code and make some adjustments. The most important thing will be to remove the last column in the dataset called "2020/2021", which contains information about the students who started their mobility in this course units in 2020/2021 (first semester). We then train our model on the full dataset for all course units, but only predict course units from IPB University. From the values obtained, we plot the graph.

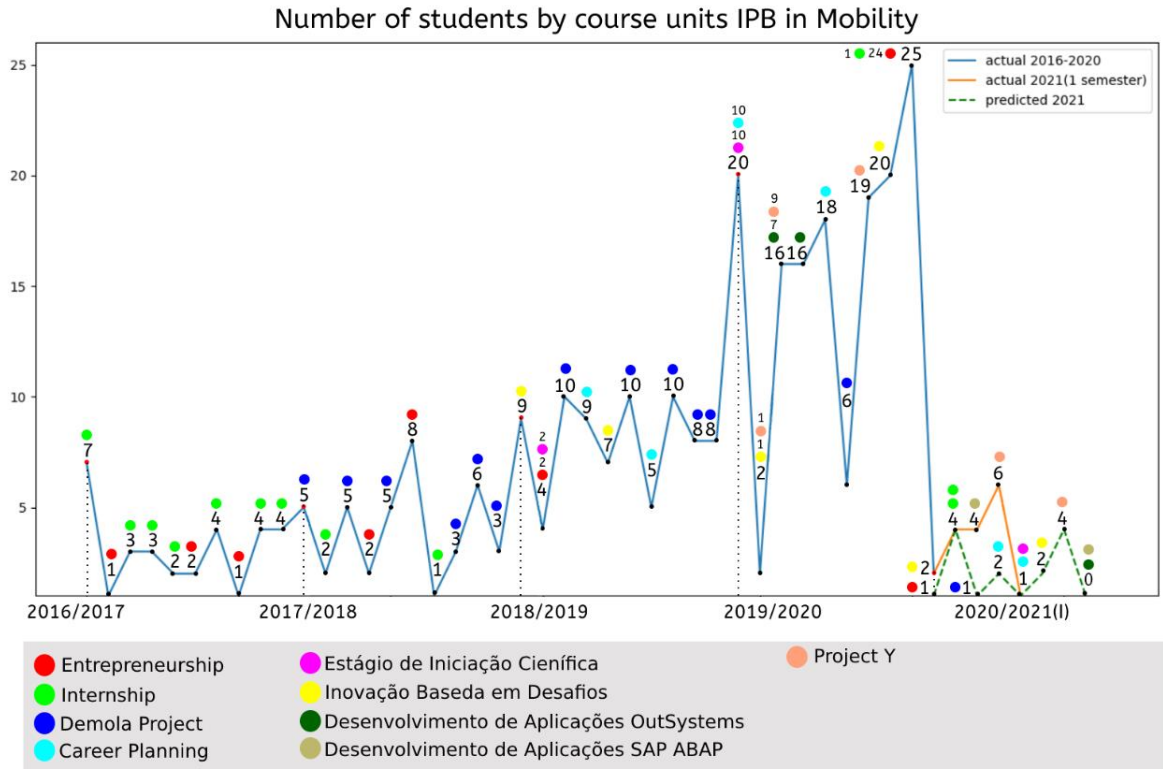

Figure 5.39: Result of Random Forest for prediction 2020/2021 years

As a result, the Random Forest algorithm predicted the following values: Entrepreneurship - 1 student, Internship - 4 students, Demola Project - 1 student, Career Planning - 2 students, Estágio de Iniciação Científica - 1 student, Inovação Baseda em Desafios - 1 student, Project Y - 4 students, Desenvolvimento de Aplicações SAP ABAP - 0 students, Desenvolvimento de Aplicações OutSystems - 0 students. As we can see, as a result, the predicted values differ from the actual values, judging from the first month. This is because the algorithm will predict lower values if the number of students in a particular course unit is going down, or high values if there is an increase every year, or if the number is rising and falling. Also in this algorithm, two factors from the Random Forest algorithm itself influence the predicted values: the number of trees and the depth of each tree. By changing these two factors we can achieve a change in values.

5.5 Results

If we summarize all of the above results, we can draw the following conclusions:

- 1) 2017/2018 - the most new students enrolled in a given period of time; 2020/2021 (first semester) - the least number of new students enrolled in a given period of time.
- 2) There were 2,515 male genders and 1,464 female genders enrolled for the entire period.
- 3) The largest number of students were from Portugal - 2,901 students, the least number came from China and Belarus - 1 student each.
- 4) The most popular course during this period was Engenharia Informática with 406 students enrolled in this course, fewer students enrolled in Tecnologia Alimentar, Gestão de Operações e Logística, Acompanhamento de Crianças e Jovens, Ilustração e Arte Gráfica, Animação e Produção Artística one student per course.
- 5) A total of 3,570 bachelors, 284 masters and 125 CTeSP entered the university during this period of time.
- 6) The most students came through Concurso Nacional de Acesso - 1,500 students - and the least through Mud. Curso Estrangeiros - only 1 student.
- 7) The highest average of the averages of unaccredited subjects was 17.98 and the lowest was 10.25.
- 8) The highest average of the averages of accredited subjects was 19.15 and the lowest was 10.
- 9) The highest value out of the total value of accredited subjects was 31 and the lowest was 1.
- 10) The highest value of the total value of accredited subjects was 200 and the lowest was 3.
- 11) The most popular course unit during this time period was Estatística, with 501 students.
- 12) The largest number of students participating in Erasmus mobility came from Poland (337) and the smallest number came from the United Kingdom, Itália, Pólonia, Romenia, Belgium, Hungria, Croat and México (1 student each).

- 13) The largest number of students in the mobility came from the Instituto Politécnico de Bragança (Portugal) - 280 students.
- 14) The most popular unit course in mobility was the Demola Project, with 79 students.

6. Conclusions and Future works

I propose to review the research in detail in my dissertation and consolidate our results.

In the first chapter we explained the relevance of this work and its structure. In the second chapter of the thesis we discussed the concept of Big Data in detail. We gave examples from the history of the formation of the concept of Big Data, types of Big Data and characteristics. In general, described the process of working and analyzing Big Data. The third chapter of the thesis was devoted to the process of data mining. Classes of data mining, neural networks and decision trees, which were considered and described in our work. The fourth chapter gave actual examples of data analysis tools and methods and techniques for each type. We also described the data analysis algorithms. In the main fifth chapter of the thesis, we performed a baseline study and evaluated the results. Descriptive analysis, predictive analysis, and correlation were described in detail and presented visually as graphs. Three machine learning algorithms were considered for our task, the best of them was selected and the advantages and disadvantages of each algorithm were described as evidence. In the appendix we placed graphs of data dependencies and tables on the given data sets for the remaining cases.

For activity in university:

General characterization by year:

School: According to the schedule it is clear that the most popular for 5 years was the "ESTiG". As we can see, the ESTiG outperforms all other schools by a wide margin in terms of student enrollment;

Course: Top 5 courses for ESA: 1) Engenharia do Ambiente, 2)Engenharia Agronómica, 3) Engenharia Zootécnica, 4) Enfermagem Veterinária, 5) Biologia e Biotecnologia. Top 5 courses for EsACT: 1)Multimédia, 2)Design de Jogos Digitais, 3)Marketing, 4)Gestão e Administração Pública, 5)Turismo. Top 5 courses for ESE: 1) Línguas para Relações Internacionais, 2) Desporto, 3) Arte e Design, 4) Educação Social, 5) Línguas Estrangeiras: Inglês e Espanhol. Top 5 courses for ESSa: 1) Farmácia, 2) Enfermagem, 3) Ciências Biomédicas Laboratoriais, 4) Dietética e Nutrição, 5) Enfermagem Médico-Cirúrgica. Top 5 courses for ESTiG: 1) Engenharia Eletrotécnica e de Computadores , 2) Gestão, 3) Gestão de

Negócios Internacionais (Curso Europeu), 4) Informática de Gestão, 5) Engenharia Informática. According to the available research, we can identify the top 5 most popular areas of university in terms of the number of students for a given period of time: 1) Engenharia Informática – 406 students in a given period of time – which is 17,57% of the total number of students who have been absent. 2) Gestão – 357 students in a given period of time – which is 15,45% of the total number of students who have been absent. 3) Gestão de Negócios Internacionais (Curso Europeu) – 239 students in a given period of time – which is 10,34% of the total number of students who have been absent. 4) Informática de Gestão – 198 students in a given period of time – which is 8,57% of the total number of students who have been absent. 5) Engenharia Eletrotécnica e de Computadores – 182 students in a given period of time – which is 7,88% of the total number of students who have been absent.

Gender: Each year the number of male students enrolled in university exceeds the number of female students by about 12,96-36,2 percent.

Age: We can build a list of student ages according to the number of students in descending order: 1) Students 21-23 years' old; 2) Students 24-26 years' old; 3) Students 27-30 years' old; 4) Students 18-20 years' old; 5) Students 31-35 years' old; 6) Students >35 years' old.

Concelho: Top for Braganca: Braganca, Modadouro, Mirandela, Macedo de Cavaleiros, Torre de Moncorvo. Top for Lisboa: Lisboa, Odivelas, Amadora, Sintra, Loures. Top for Porto: Felgueiras, Paredes, Marco de Canaveses, Penafiel, Amarante. Top for Vila Real: Vila Real, Valpacos, Chaves, Alijo, Vila Pouco de Aguiar.

Distrito: The most popular districts are: Braganca, Vila Real, Lisbon and Porto.

Degree: The university contains bachelors the most, followed by masters and CTeSP.

Type entry: Top: Concurso Nacional de Acesso, DET, Concurso Local, Estudantes Internacionais, DTeSP(Titulares CTeSP)

Nationality: Top: Portugal, Cabo Verde, Brasil, Paquistao, Sao Tome e Principe.

Average of the not credit subjects: The highest average score was in 2019/2020 at 13.28, and the lowest average score was in 2020/2021 at 12.36.

Average of the credited subjects: The highest average score was in 2016/2017 at 14.42, and the lowest average score was in 2017/2018 at 13.84.

Total subjects credited: The highest total score was in 2019/2020 at 2061, and the lowest total score was in 2020/2021 at 327.

Sum of the subjects credited (sum ECTS): The highest sum score was in 2018/2019 at 12526, and the lowest sum score was in 2020/2021 at 2112.

Final average: The highest average score was in 2016/2017 at 13.51, and the lowest average score was in 2020/2021 at 12.95.

General characterization by School:

Course: Top 5 courses for “Escola Superior Agrária de Bragança”: 1) Engenharia do Ambiente; 2) Engenharia Agronómica; 3) Engenharia Zootécnica; 4) Enfermagem Veterinária; 5) Biologia e Biotecnologia; Top 5 courses for “Escola Superior de Comunicação, Administração e Turismo”: 1) Multimédia; 2) Design de Jogos Digitais; 3) Marketing; 4) Gestão e Administração Pública; 5) Turismo; Top 5 courses for “Escola Superior de Educação de Bragança”: 1) Línguas para Relações Internacionais; 2) Desporto; 3) Arte e Design; 4) Educação Social; 5) Línguas Estrangeiras: Inglês e Espanhol; Top 5 courses for “Escola Superior de Saúde de Bragança”: 1) Farmácia; 2) Enfermagem; 3) Ciências Biomédicas Laboratoriais; 4) Dietética e Nutrição; 5) Enfermagem Médico-Cirúrgica; Top 5 courses for “Escola Superior de Tecnologia e Gestão de Bragança”: 1) Engenharia Eletrotécnica e de Computadores; 2) Gestão; 3) Gestão de Negócios Internacionais (Curso Europeu); 4) Informática de Gestão; 5) Engenharia Informática.

Gender: We can determine that the number of male students exceeds the number of female students in the following schools: Escola Superior Agrária de Bragança, Escola Superior de Tecnologia e Gestão de Bragança and Escola Superior de Comunicação, Administração e Turismo. And the number of girls exceeds the number of boys in the following schools: Escola Superior de Saúde de Bragança and Escola Superior de Educação de Bragança.

Age: We can build a list of student ages according to the number of students in descending order: 1) Students 21-23 years' old; 2) Students 24-26 years' old; 3) Students 27-30 years' old; 4) Students 18-20 years' old; 5) Students 31-35 years' old; 6) Students >35 years' old.

Concelho: Top Bragança: Bragança, Macedo de Cavaleiros, Mogadouro, Mirandela, Vinhais. Top Lisboa: Odivelas, Amadora, Lisboa, Sintra, Vila Franca de Xira, Loures, Azambuja, Oeiras, Sobral de Monte Agraça. Top Porto: Felgueiras, Paredes, Marco de Canaveses, Penafiel, Amarante. Top Vila Real: Valpaços, Chaves, Alijo, Vila Real, Vila Pouco de Aguiar.

Distrito: The most popular districts are: Braganca, Vila Real, Lisbon and Porto.

Type entry: Top: DET, Concurso Nacional de Acesso, Concurso Local, Estudantes Internacionais, DTeSP (Titulares CTeSP)

Nationality: Top: Portugal, Cabo Verde, Brasil, Paquistao, Sao Tome e Principe.

Average of the not credit subjects: The highest average score was in Escola Superior de Saúde de Bragança at 14.17, and the lowest average score was in Escola Superior de Tecnologia e Gestão de Bragança at 12.61.

Average of the credited subjects: . The highest average score was in Escola Superior de Saúde de Bragança at 15.29, and the lowest average score was in Escola Superior Agrária de Bragança at 13.29.

Total subjects credited: The highest total score was in Escola Superior de Tecnologia e Gestão de Bragança at 3519, and the lowest total score was in Escola Superior Agrária de Bragança at 600.

Sum of the subjects credited (sum ECTS): The highest total score was in Escola Superior de Tecnologia e Gestão de Bragança at 21059, and the lowest total score was in Escola Superior Agrária de Bragança at 3620.

Final average: The highest average score was in Escola Superior de Saúde de Bragança at 14.50, and the lowest average score was in Escola Superior de Tecnologia e Gestão de Bragança at 13.11.

General characterization by School and Course:

Gender: Escola Superior Agrária de Bragança: The number of male students exceeds the number of female students. Escola Superior de Educação de Bragança: The number of female students exceeds the number of male students.), Escola Superior de Tecnologia e Gestão de Bragança: The number of male students exceeds the number of female students. Escola Superior de Comunicação, Administração e Turismo: The number of male students exceeds the number of female students. Escola Superior de Saúde de Bragança: The number of male students exceeds the number of female students.

Age: Escola Superior Agrária de Bragança: We build a list of student ages according to the number of students in descending order: 1)Students 24-26 years' old; 2)Students 21-23 years'

old; 3)Students 27-30 years' old; 4)Students 18-20 years' old; 5)Students 31-35 years' old; 6)Students >35 years' old. Escola Superior de Comunicação, Administração e Turismo: We can build a list of student ages according to the number of students in descending order:1)Students 21-23 years' old; 2)Students 24-26 years' old; 3)Students 18-20 years' old; 4)Students 31-35 years' old; 5)Students 27-30 years' old; 6)Students >35 years' old. Escola Superior de Educação de Bragança: We can build a list of student ages according to the number of students in descending order: 1)Students 21-23 years' old; 2)Students 24-26 years' old; 3)Students 27-30 years' old; 4)Students 18-20 years' old; 5)Students 31-35 years' old; 6)Students >35 years' old. Escola Superior de Saúde de Bragança: We can build a list of student ages according to the number of students in descending order: 1)Students 21-23 years' old; 2)Students 24-26 years' old; 3)Students 27-30 years' old; 4)Students 18-20 years' old; 5)Students >35 years' old; 6)Students 31-35 years' old. Escola Superior de Tecnologia e Gestão de Bragança: We can build a list of student ages according to the number of students in descending order: 1)Students 21-23 years' old; 2)Students 24-26 years' old; 3)Students 27-30 years' old; 4)Students 18-20 years' old; 5)Students 31-35 years' old; 6)Students >35 years' old.

Concelho: Escola Superior Agrária de Bragança: Braganca, Mogadouro, Porto. Escola Superior de Comunicação, Administração e Turismo: Mirandela, Chaves, Braganca. Escola Superior de Educação de Bragança: Paredes, Braganca, Mirandela. Escola Superior de Saúde de Bragança: Braganca, Mirandela, Vila Real, Baião, Marco de Canaveses. Escola Superior de Tecnologia e Gestão de Bragança: Braganca, Chaves, Penafiel.

Distrito: The most popular districts are: Braganca, Vila Real, Lisbon and Porto.

Type entry: Escola Superior Agrária de Bragança: DET, Estudantes Internacionais, DTeSP (Titulares CTeSP). Escola Superior de Comunicação, Administração e Turismo: DET, Estudantes Internacionais, Concurso Nacional de Acesso. Escola Superior de Educação de Bragança: Estudantes Internacionais, Concurso Nacional de Acesso, Mudança de Curso. Escola Superior de Saúde de Bragança: Estudantes Internacionais, Concurso Nacional de Acesso, Mudança de Curso. Escola Superior de Tecnologia e Gestão de Bragança: Estudantes Internacionais, Concurso Nacional de Acesso, DET.

Nationality: Escola Superior Agrária de Bragança: Portugal, Cabo Verde, Brasil, Angola. Escola Superior de Comunicação, Administração e Turismo: Portugal, Brasil, Sao Tome e Principe, Cabo Verde, Guine-Bissau. Escola Superior de Educação de Bragança: Portugal,

Cabo Verde. Escola Superior de Saúde de Bragança: Portugal, Cabo Verde, Sao Tome e Principe. Escola Superior de Tecnologia e Gestão de Bragança: Portugal, Cabo Verde, Sao Tome e Principe.

Average of the not credit subjects: Escola Superior Agrária de Bragança: The highest average score was in Gestão de Recursos Florestais at 15.50, and the lowest average score was in Engenharia Zootécnica at 11.75. Escola Superior de Comunicação, Administração e Turismo: The highest average score was in Comunicação Digital at 15.05, and the lowest average score was in Gestão e Administração Pública at 12.51. Escola Superior de Educação de Bragança: The highest average score was in Acompanhamento de Crianças e Jovens at 16.95, and the lowest average score was in Desporto at 12.47. Escola Superior de Saúde de Bragança: The highest average score was in Gerontologia at 15.31, and the lowest average score was in Dietética e Nutrição at 12.86. Escola Superior de Tecnologia e Gestão de Bragança: The highest average score was in Tecnologia Biomédica at 15.81, and the lowest average score was in Engenharia Química e Biológica at 11.00.

Average of the credited subjects: Escola Superior Agrária de Bragança: The highest average score was in Engenharia Alimentar at 15.00, and the lowest average score was in Engenharia do Ambiente at 13.04. Escola Superior de Comunicação, Administração e Turismo: The highest average score was in Informática e Comunicações at 15.38, and the lowest average score was in Multimédia at 13.46. Escola Superior de Educação de Bragança: The highest average score was in Música at 16.59, and the lowest average score was in Tradução at 12.00. Escola Superior de Saúde de Bragança: The highest average score was in Farmácia at 16.41, and the lowest average score was in Bioanálises e Controlo at 14.00. Escola Superior de Tecnologia e Gestão de Bragança: The highest average score was in Gestão das Organizações at 16.90, and the lowest average score was in Análises Químicas e Biológicas at 10.00 and Planeamento e Condução de Obra at 10.00.

Total subjects credited: Escola Superior Agrária de Bragança: The highest total score was in Engenharia Agronómica at 203, and the lowest total score was in Qualidade e Segurança Alimentar at 1. Escola Superior de Comunicação, Administração e Turismo: The highest total score was in Multimédia at 457, and the lowest total score was in Administração e Negócios at 1. Escola Superior de Educação de Bragança: The highest total score was in Línguas para Relações Internacionais at 457, and the lowest total score was in Tradução at 1. Escola Superior de Saúde de Bragança: The highest total score was in Enfermagem at 1034, and the

lowest total score was in Bioanálises e Controlo at 1. Escola Superior de Tecnologia e Gestão de Bragança: The highest total score was in Gestão at 851, and the lowest total score was in Energias Renováveis e Infraestruturas Elétricas e de Telecomunicações at 1 and Planeamento e Condução de Obra at 1 and Análises Químicas e Biológicas at 1.

Sum of the subjects credited (sum ECTS): Escola Superior Agrária de Bragança: The highest sum score was in Engenharia Agronómica at 1218, and the lowest sum score was in Qualidade e Segurança Alimentar at 12. Escola Superior de Comunicação, Administração e Turismo: The Y-axis represents courses, and the X-axis represents the sum value. The highest sum score was in Multimédia at 2592, and the lowest sum score was in Administração e Negócios at 6. Escola Superior de Educação de Bragança: The highest sum score was in Línguas para Relações Internacionais at 2708, and the lowest sum score was in Tradução at 5. Escola Superior de Saúde de Bragança: The highest sum score was in Enfermagem at 2708, and the lowest sum score was in Bioanálises e Controlo at 5. Escola Superior de Tecnologia e Gestão de Bragança: The highest sum score was in Gestão at 5142, and the lowest sum score was in Energias Renováveis e Infraestruturas Elétricas e de Telecomunicações at 3 and Análises Químicas e Biológicas at 3.

Final average: Escola Superior Agrária de Bragança: The highest average score was in Gestão de Recursos Florestais at 15.25, and the lowest average score was in Engenharia do Ambiente at 12.22. Escola Superior de Comunicação, Administração e Turismo: The highest average score was in Administração e Negócios at 15.00 and Comunicação Digital at 15.00 and Solicitadoria at 15.00; the lowest average score was in Gestão e Administração Pública at 13.07. Escola Superior de Educação de Bragança: The highest average score was in Acompanhamento de Crianças e Jovens at 17.00, and the lowest average score was in Desporto at 12.64. Escola Superior de Saúde de Bragança: The highest average score was in Gerontologia at 15.50, and the lowest average score was in Dietética e Nutrição at 13.33. Escola Superior de Tecnologia e Gestão de Bragança: The highest average score was in Tecnologia Biomédica at 16.00, and the lowest average score was in Engenharia Biomédica at 11.33.

For activities in mobility:

General characterization by Course in Mobility:

Average Grade: 2016/2017: The highest average score was in Tecnologia Biomédica at 20.00, and the lowest average score was in Engenharia Biomédica at 12.00. 2017/2018: The highest average score was in Tradução at 20.00, and the lowest average score was in Biologia e Biotecnologia at 12.67. 2018/2019: The highest average score was in Ciências Biomédicas Laboratoriais at 19.89, and the lowest average score was in Qualidade e Segurança Alimentar at 13.00. 2019/2020: The highest average score was in Multimédia at 19.66, and the lowest average score was in Tradução at 10.00. 2020/2021: The highest average score was in Ciências Biomédicas Laboratoriais at 20.00, and the lowest average score was in Engenharia Agronómica at 12.00.

ECTS Average: 2016/2017: The highest average score was in Farmácia at 30.00, and the lowest average score was in Desporto at 2.00. 2017/2018: The highest average score was in Ciências Biomédicas Laboratoriais at 30.00, and the lowest average score was in Desporto at 2.50. 2018/2019: The highest average score was in Ciências Biomédicas Laboratoriais at 30.00, and the lowest average score was in Desporto at 2.46. 2019/2020: The highest average score was in Ciências Biomédicas Laboratoriais at 14.48, and the lowest average score was in Multimédia at 3.42. 2020/2021: The highest average score was in Enfermagem at 15.00, and the lowest average score was in Informática de Gestão at 4.50.

General characterization by Country in Mobility:

Average Grade: 2016/2017: The highest average score was in Polonia at 20.00, and the lowest average score was in Greece at 13.13. 2017/2018: The highest average score was in France at 19.00, and the lowest average score was in Italia at 11.00. 2018/2019: The highest average score was in Romania at 18.33, and the lowest average score was in Latvia at 12.14. 2019/2020: The highest average score was in Romania at 20.00, and the lowest average score was in Brasil at 11.00. 2020/2021: The highest average score was in Slovakia at 17.86, and the lowest average score was in Spain at 14.20.

ECTS Average: 2016/2017: The highest average score was in United Kingdom at 30.00 and in Francia at 30.00, and the lowest average score was in Polonia at 2.00. 2017/2018: The highest average score was in Francia at 30.00, and the lowest average score was in Polonia at 2.11. 2018/2019: The highest average score was in Belgium at 30.00, and the lowest average score was in China at 2.56. 2019/2020: The highest average score was in Romania at 30.00, and the lowest average score was in China at 2.78. 2020/2021: The highest average score was in France at 15.00, and the lowest average score was in Finland at 3.33.

General characterization by Institution in Mobility:

Average Grade: 2016/2017: The highest average score was in Universitatea Aurel Vlaicu din Arad at 20.00, and the lowest average score was in School of Pedagogical and Technological Education at 12.00. 2017/2018: The highest average score was in Universidad de Salamanca at 19.50, and the lowest average score was in Università Di Bologna at 11.00. 2018/2019: The highest average score was in Alexander Technological Educational Institution of Tessaloniki at 20.00 and in Hospital Virgen de la Concha at 20.00, and the lowest average score was in Universitatea Polytechnica din Timisoara at 10.90. 2019/2020: . The highest average score was in University of Silesia in Katowice at 20.00, and the lowest average score was in Universidad de Castilla La-Mancha at 10.00. 2020/2021: The highest average score was in The Witelon State University of Applied Sciences in Legnica at 18.68, and the lowest average score was in ESTiG at 14.00.

Average ECTS: 2016/2017: The highest ECTS score was in Institut de Formation en Soins Infirmiers Virginie Olivier at 30.00, Facultad de Ciencias de la Salud - Universidade de Leon at 30.00, Hospital Virgen de la Concha at 30.00, Sussex Health Care at 30.00, Universidade de Sevilha at 30.00; the ECTS average score was in Wroclaw University of Technology at 2.05. 2017/2018: The highest ECTS score was in Institut de Formation en Soins Infirmiers Virginie Olivier at 30.00, EOXI DE OURENSE, VENIX E O BARCO DE VALDEORMS at 30.00, Universidad Autonoma de Baja California at 30.00, Hospital Virgen de la Concha at 30.00; the ECTS average score was in PL KRAKOW12 - University School of Physical Education at 2.25. 2018/2019: The highest ECTS score was in Hospital Virgen de la Concha at 30.00, Mani Häusliche Pflege at 30.00, Hospital Universitario de Ourense at 30.00, Alexander Technological Educational Institution of Tessaloniki at 30.00, Thomas More University College at 30.00; the ECTS average score was in PL KRAKOW12 - University School of Physical Education at 2.25. 2019/2020: The highest ECTS score was in Hospital Virgen de la Concha at 30.0; the ECTS average score was in BNUZ Beijing Normal University Zhuhai at 2.00. 2020/2021: The highest ECTS score was in Centre Hospitalier Albertville Moutiers at 15.0; the ECTS average score was in Kajaani University of Applied Sciences at 3.33.

A correlation was also found between students' grades and the countries to which they could go, depending on their current average grades. For example, students with higher grades, such

as 19-20, were more likely to go to countries such as Mexico, Italy, Slovakia, Finland, Slovenia, United Kingdom, France, Croatia, Germany.

I believe that this work can be improved in the future and do more extensive work on his concepts by building a program for specific tasks. A possible future work is to create an automatic model based on machine learning algorithms to create and determine the factor dependencies of already new models in datasets and visualize the same data on graphs with support on the server side and a web page. As well as for predicting external and internal factors from available datasets to predict required values.

7. References

- [1]. Allen B. Downey (O'Reilly, 2015), "Think Python: How to Think Like a Computer Scientist, 2nd edition"
- [2]. Viktor Mayer-Schönberger and Kenneth Cukier, "Big Data: A Revolution That Will Transform How We Live, Work, and Think"
- [3]. Drew Conway and John Myles White, "Machine Learning for Hackers: Case Studies and Algorithms to Get you Started"
- [4]. Trevor Hastie, Robert Tibshirani, and Jerome Friedman, "The Elements of Statistical Learning: Data Mining, Inference, and Prediction"
- [5]. Steven Bird, Ewan Klein, and Edward Loper, "Natural Language Processing with Python"
- [6]. Jared Dean, "Big Data, Data Mining, and Machine Learning: Value Creation for Business Leaders and Practitioners"
- [7]. Anand Rajaraman and Jeffrey David Ullman, "Mining of Massive Datasets"
- [8]. Jake Vanderplas, "Python Data Science Handbook"
- [9]. Wes McKinney, "Python for Data Analysis"
- [10]. Robert Johansson, "Numerical Python: Scientific Computing and Data Science Applications with Numpy, SciPy, and Matplotlib"
- [11]. Nazarenko Yu.L., "TECHNOLOGY REVIEW "BIG DATA" AND SOFTWARE FACILITIES APPLICABLE FOR IT ANALYSIS AND PROCESSING"
- [12]. <https://matplotlib.org/stable/index.html>
- [13]. <https://seaborn.pydata.org/>
- [14]. <https://numpy.org/learn/>

- [15]. <https://pandas.pydata.org/>
- [16]. <https://scikit-learn.org/stable/index.html>
- [17]. <https://habr.com/ru/post/468295/>
- [18]. <https://www.kaggle.com/sootersaalu/exploratory-data-analysis>
- [19]. <https://www.educative.io/blog/what-is-big-data>
- [20]. <https://www.oracle.com/big-data/what-is-big-data/>
- [21]. <https://www.guru99.com/what-is-big-data.html>
- [22]. <https://medium.com/@seemadurgapal/big-data-how-can-we-prepare-for-them-3cb87d99d844>
- [23]. <https://www.ideamotive.co/blog/data-mining-vs-machine-learning-differences-similarities-use-examples>
- [24]. <https://tproger.ru/translations/top-machine-learning-algorithms/>
- [25]. <https://bernardmarr.com/how-much-data-is-there-in-the-world/>
- [26]. <https://blog.iteam.ru/data-mining-intellektualnyj-analiz-dannyh/>
- [27]. <https://ibm.com/cloud/learn/data-mining>
- [28]. <https://coderlessons.com/tutorials/mashinnoe-obuchenie/nauka-o-dannykh/nauka-o-dannykh>
- [29]. <https://endnomer.ru/novosti/tehnologiya-big-data-cto-eto.html>
- [30]. <https://realpython.com/numpy-scipy-pandas-correlation-python/>

8. Annexes

8.1 Graphics

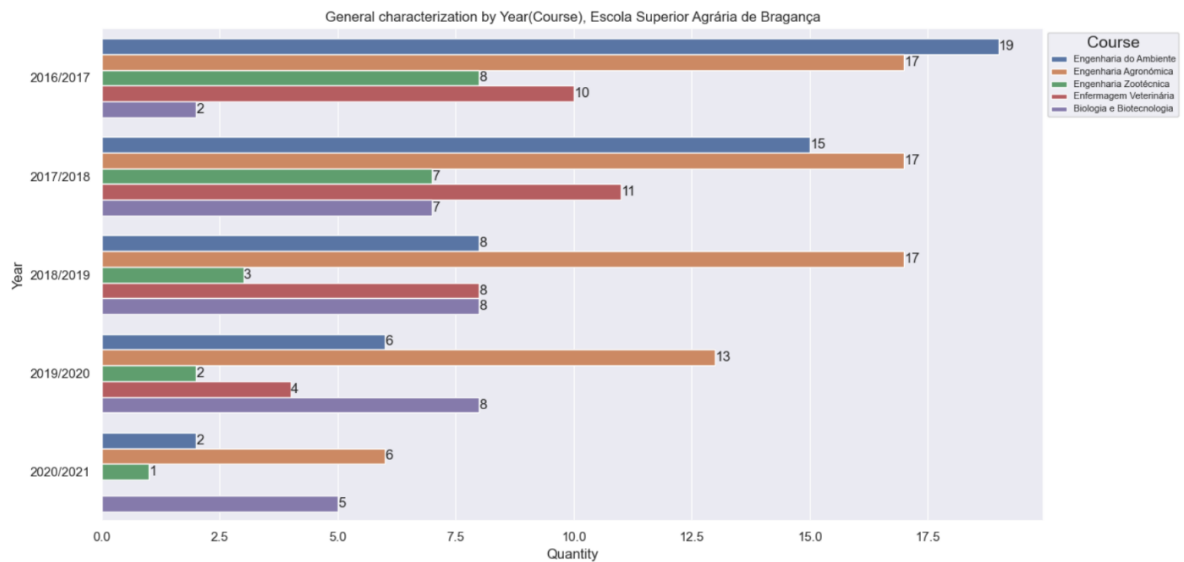

Figure 1: General characterization by Year (Course), ESA

The bar chart below shows the number of students studying the top 5 courses for the "ESA". The Y-axis represents years, and the X-axis represents the number of students. Top 5 courses for “ESA”: 1) Engenharia do Ambiente; 2) Engenharia Agronómica; 3) Engenharia Zootécnica; 4) Enfermagem Veterinária; 5) Biologia e Biotecnologia;

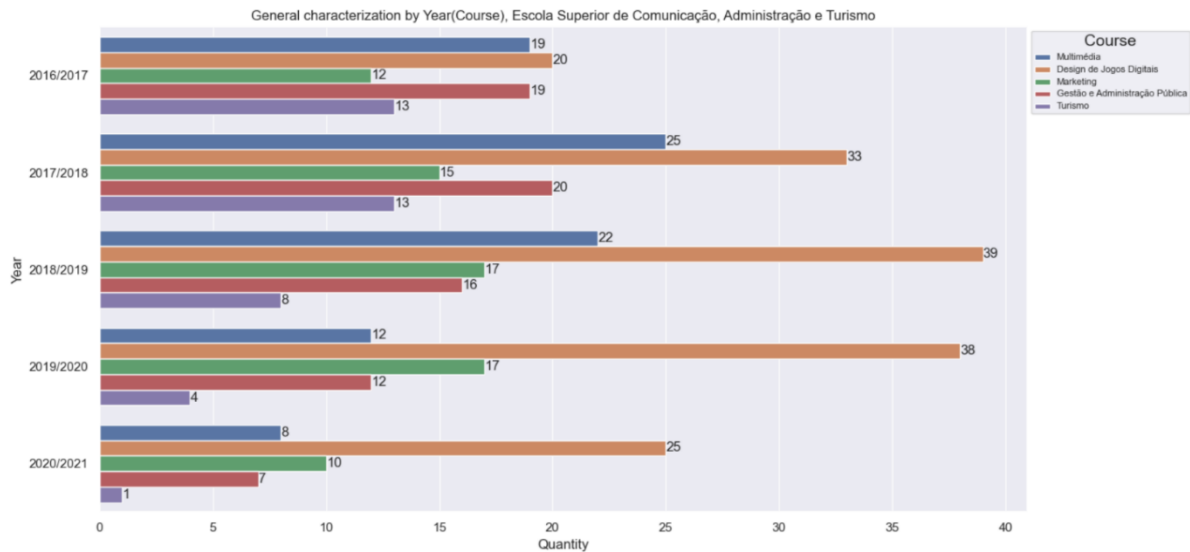

Figure 2: General characterization by Year (Course), EsACT

The bar chart below shows the number of students studying the top 5 courses for the "EsACT". The Y-axis represents years, and the X-axis represents the number of students. Top 5 courses for "EsACT": 1)Multimédia; 2)Design de Jogos Digitais; 3)Marketing; 4)Gestão e Administração Pública; 5)Turismo.

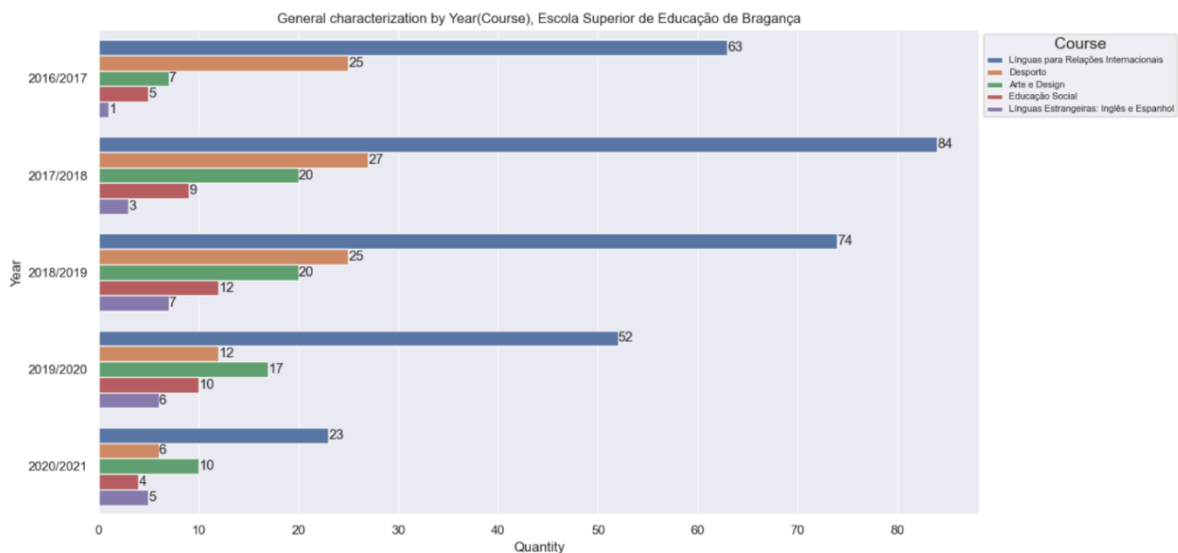

Figure 3: General characterization by Year (Course), ESE

The bar chart below shows the number of students studying the top 5 courses for the "ESE". The Y-axis represents years, and the X-axis represents the number of students. Top 5 courses

for “ESE”: 1)Línguas para Relações Internacionais; 2)Desporto; 3)Arte e Design; 4)Educação Social; 5)Línguas Estrangeiras: Inglês e Espanhol;

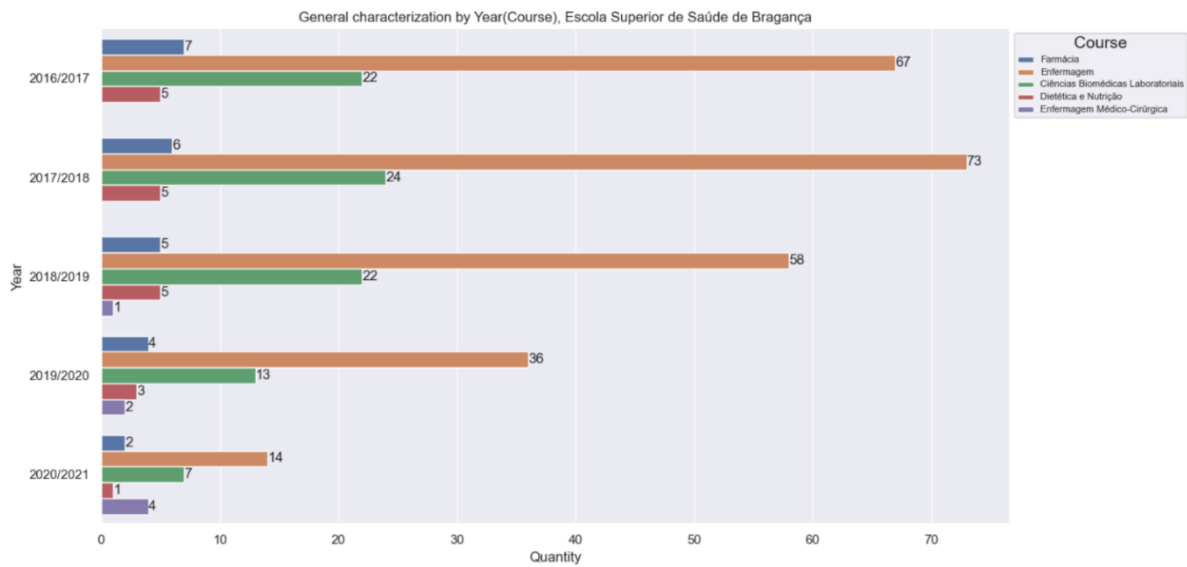

Figure 4: General characterization by Year (Course), ESSa

The bar chart below shows the number of students studying the top 5 courses for the "ESSa". The Y-axis represents years, and the X-axis represents the number of students. Top 5 courses for “ESSa”: 1)Farmácia; 2)Enfermagem; 3)Ciências Biomédicas Laboratoriais; 4)Dietética e Nutrição; 5)Enfermagem Médico-Cirúrgica.

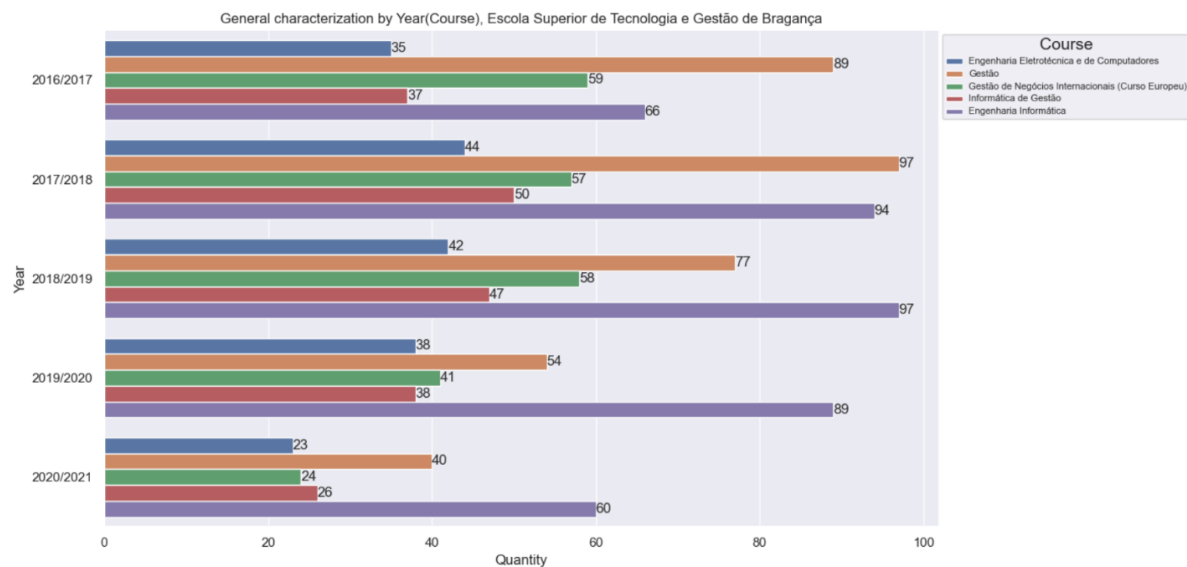

Figure 5: General characterization by Year (Course), ESTiG

The bar chart below shows the number of students studying the top 5 courses for the "ESTiG". The Y-axis represents years, and the X-axis represents the number of students. Top 5 courses for "ESTiG": 1) Engenharia Eletrotécnica e de Computadores; 2) Gestão; 3) Gestão de Negócios Internacionais (Curso Europeu); 4) Informática de Gestão; 5) Engenharia Informática.

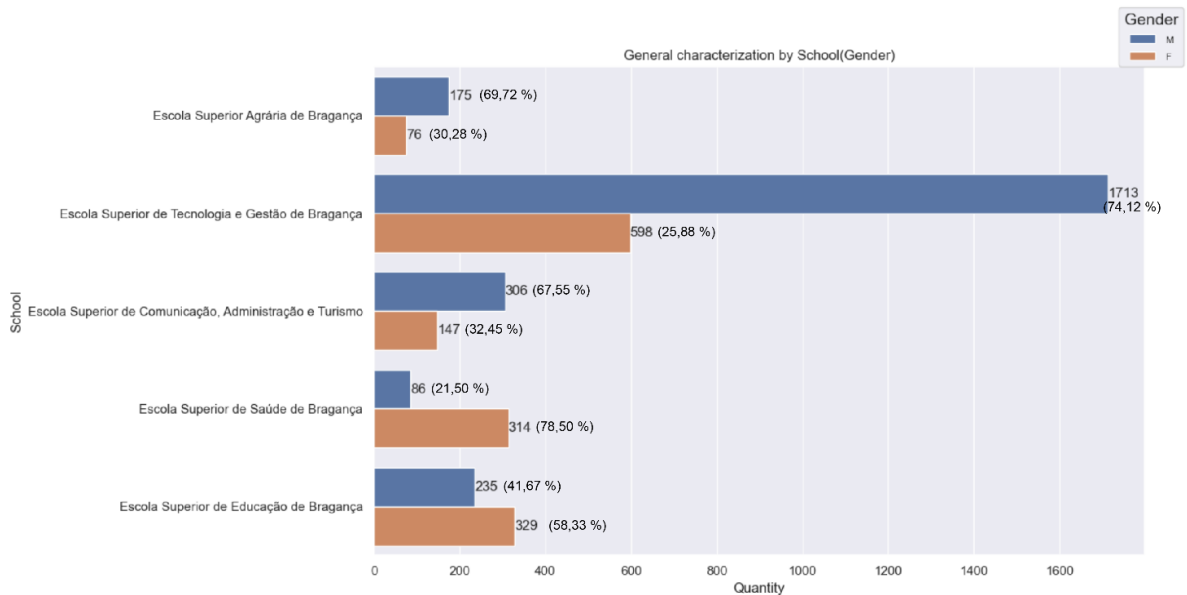

Figure 6: General characterization by School (Gender)

The bar chart below shows the number and percent of students (male and female) studying in different schools. The Y-axis represents schools, and the X-axis represents the number of students. According to this graph, we can determine that the number of male students exceeds the number of female students in the following schools: ESA, ESTiG and EsACT. And the number of girls exceeds the number of boys in the following schools: ESSa and ESE.

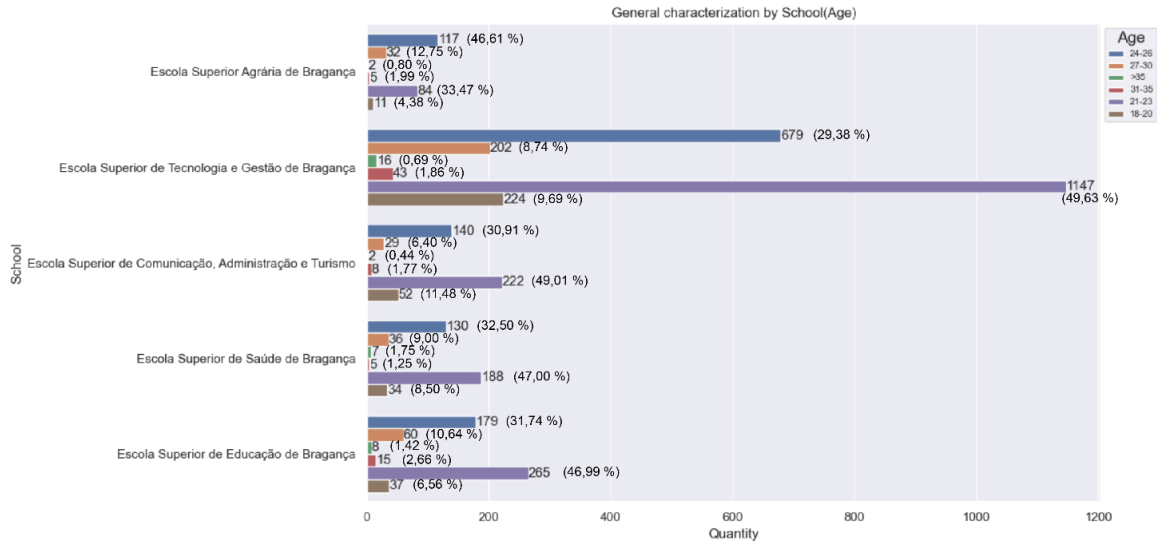

Figure 7: General characterization by School (Gender)

The bar chart below shows the number and percent of students of different ages studying in different schools. The Y-axis represents schools, and the X-axis represents the number of students. We can use this graph to build a list of student ages according to the number of students in descending order: 1) Students 21-23 years' old; 2) Students 24-26 years' old; 3) Students 27-30 years' old; 4) Students 18-20 years' old; 5) Students 31-35 years' old; 6) Students >35 years' old.

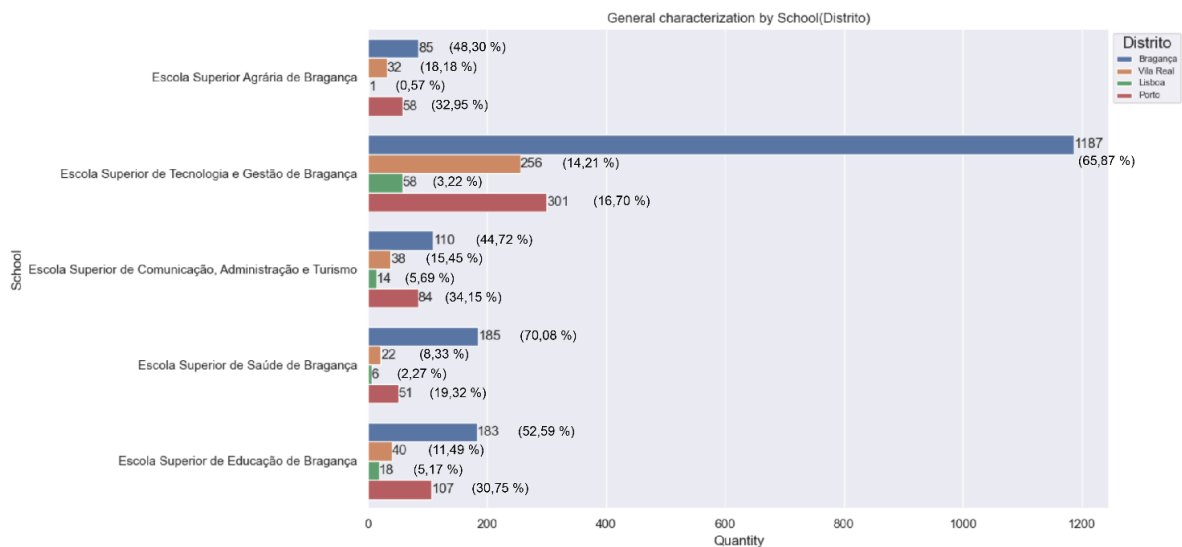

Figure 8: General characterization by School (Distrito)

The bar chart below shows the number and percent of students from different districts in different years. The Y-axis represents years, and the X-axis represents the number of students. The most popular districts are: Braganca, Vila Real, Lisbon and Porto. Below are the top 5 Concelho from each District.

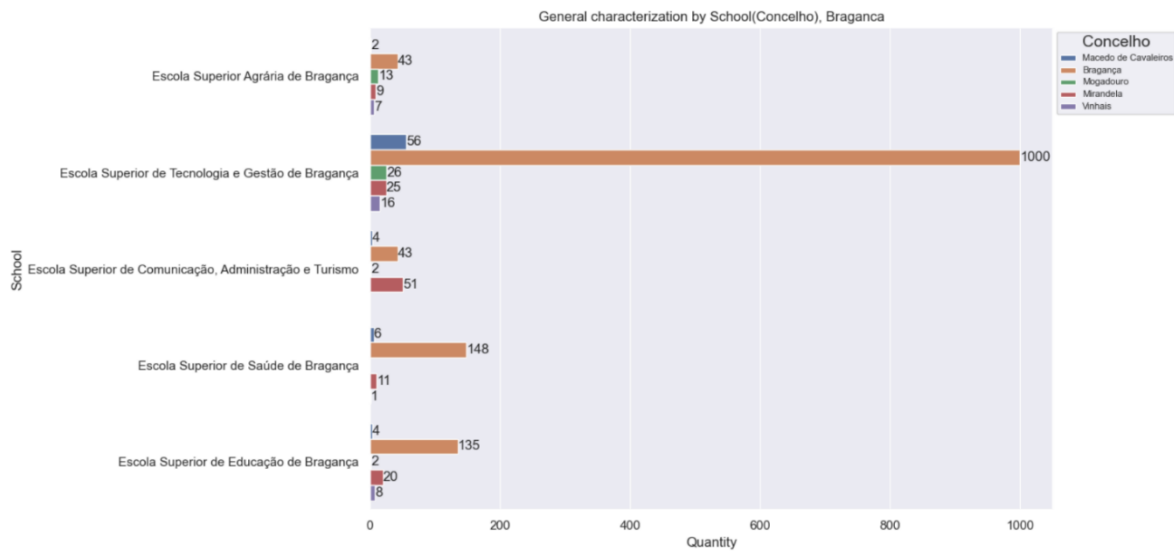

Figure 9: General characterization by School (Concelho), Braganca

The bar chart below shows the number and percent of students from top 5 regions of Braganca districts in different schools. The Y-axis represents years, and the X-axis represents the number of students.

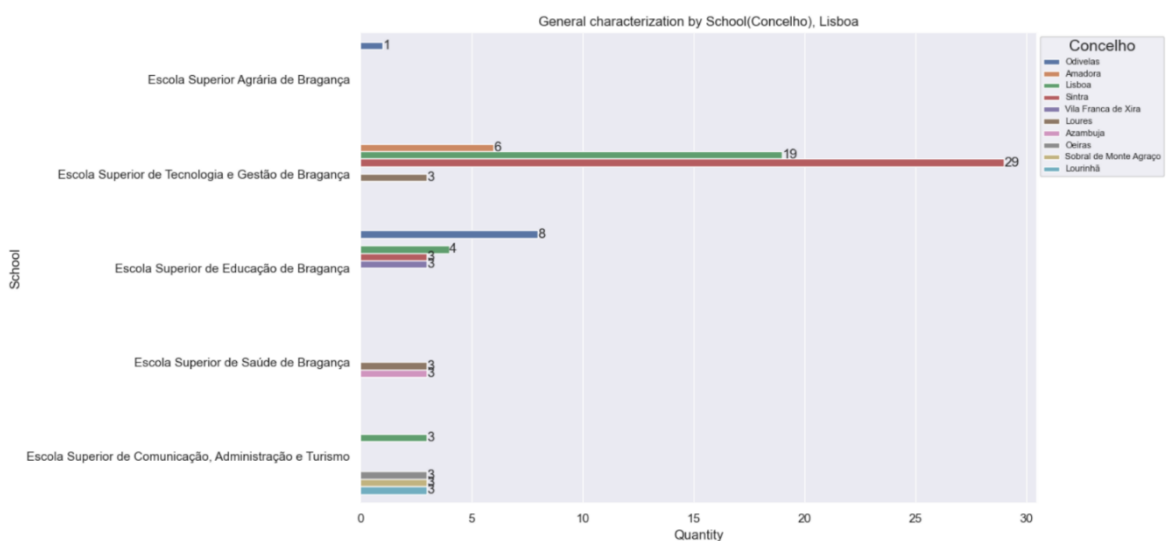

Figure 10: General characterization by School (Concelho), Lisboa

The bar chart below shows the number and percent of students from top 5 regions of Lisboa districts in different schools. The Y-axis represents years, and the X-axis represents the number of students.

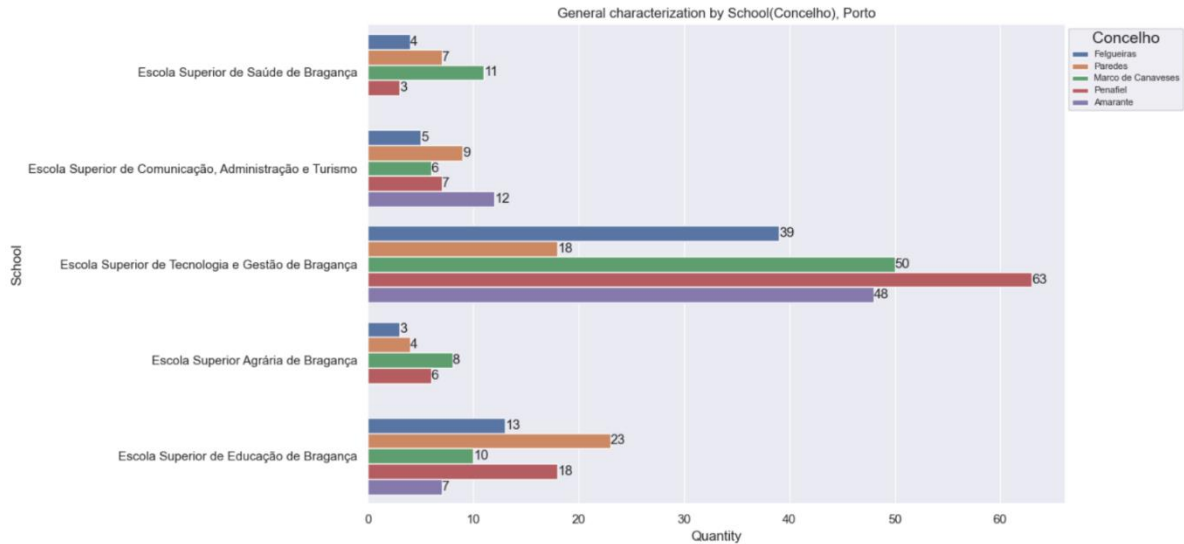

Figure 11: General characterization by School (Concelho), Porto

The bar chart below shows the number and percent of students from top 5 regions of Porto districts in different schools. The Y-axis represents years, and the X-axis represents the number of students.

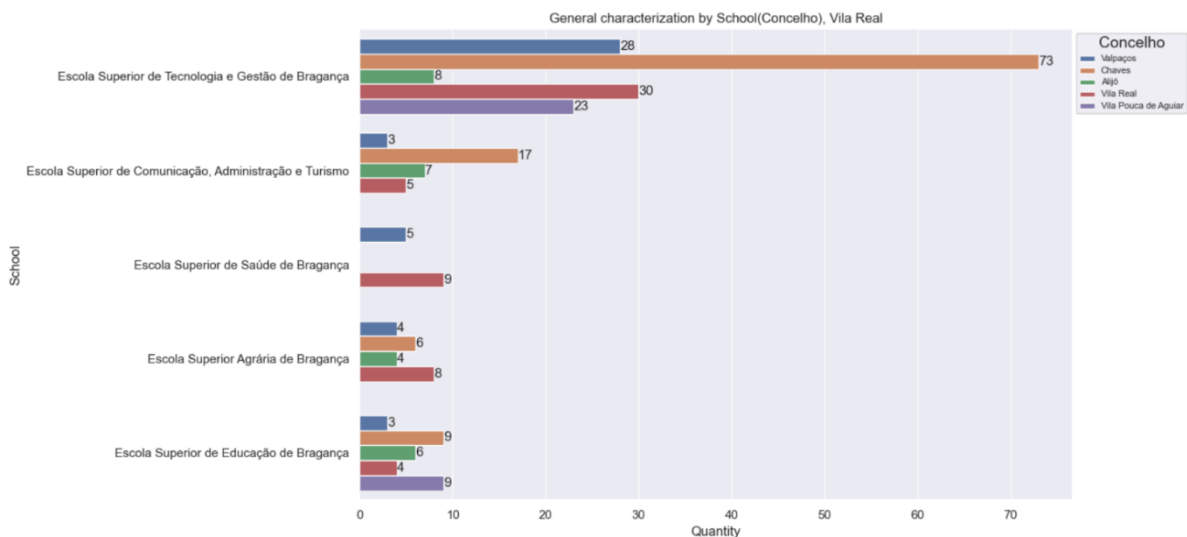

Figure 12: General characterization by School (Concelho), Vila Real

The bar chart below shows the number and percent of students from top 5 regions of Vila Real districts in different schools. The Y-axis represents years, and the X-axis represents the number of students.

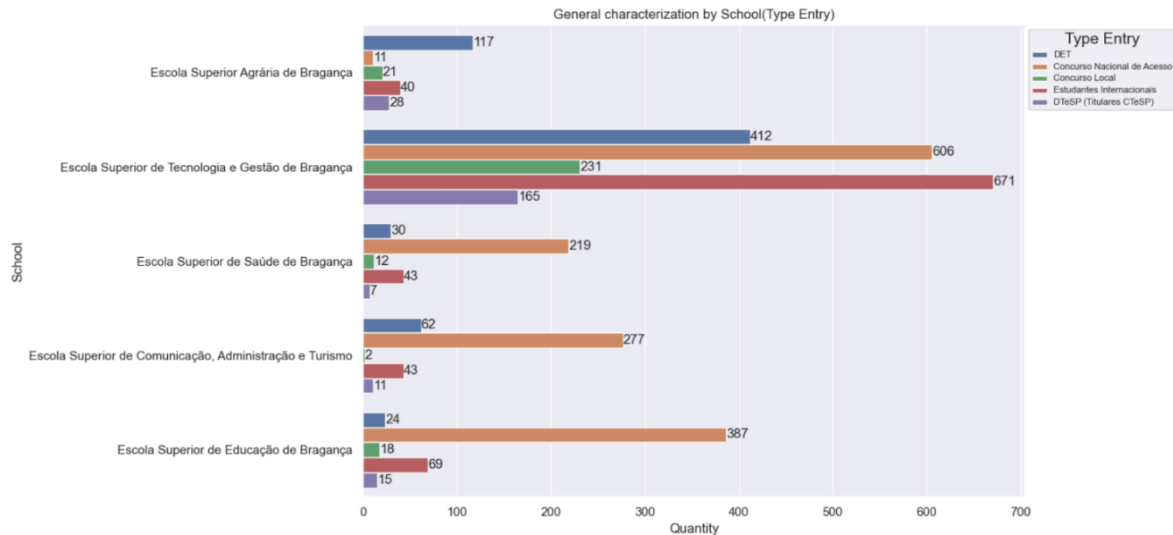

Figure 13: General characterization by School (Type Entry)

The bar chart below shows the number and of students from top 5 different type entry in different schools. The Y-axis represents schools, and the X-axis represents the number of students.

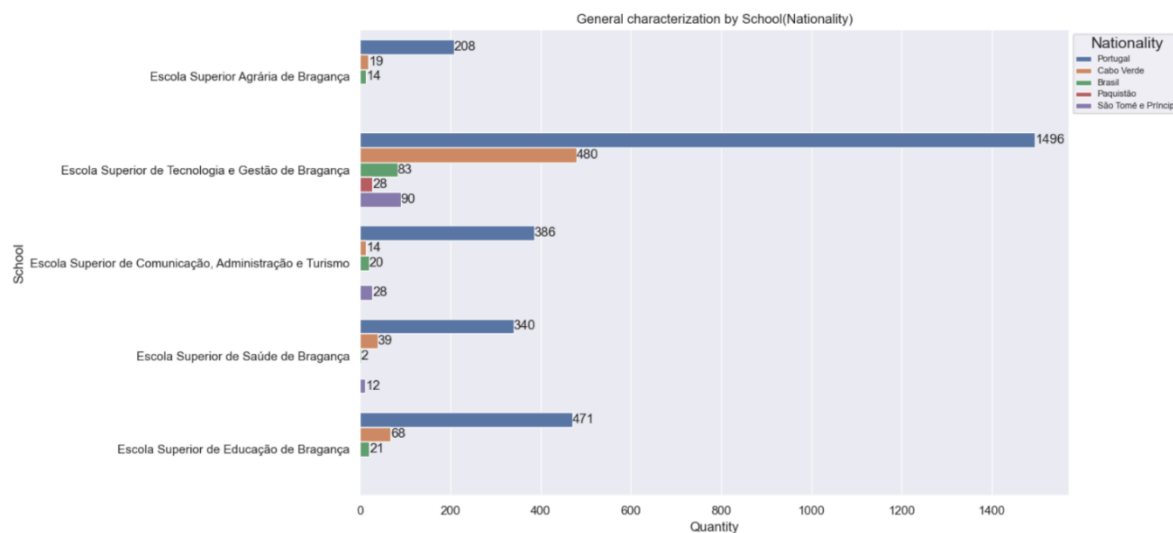

Figure 14: General characterization by School (Nationality)

The bar chart below shows the number and percent of students of top 5 nationalities in different schools. The Y-axis represents schools, and the X-axis represents the number of students.

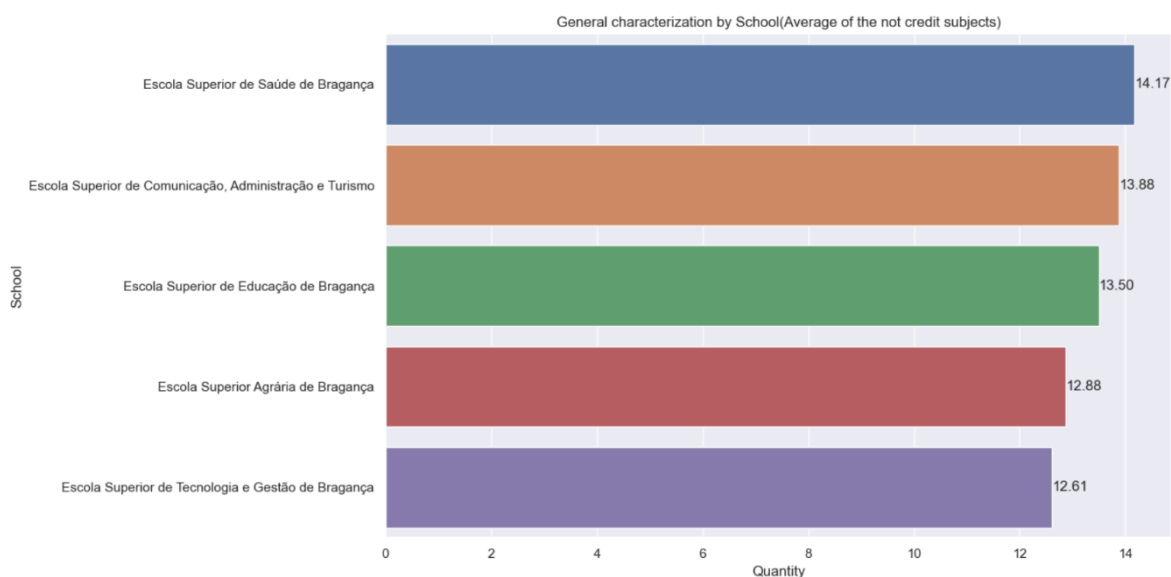

Figure 15: General characterization by School (Average of the not credit subjects)

The bar chart below shows the average number of the not credit subjects in different schools. The Y-axis represents schools, and the X-axis represents the average value. The highest average score was in ESSa at 14.17, and the lowest average score was in ESTiG at 12.61.

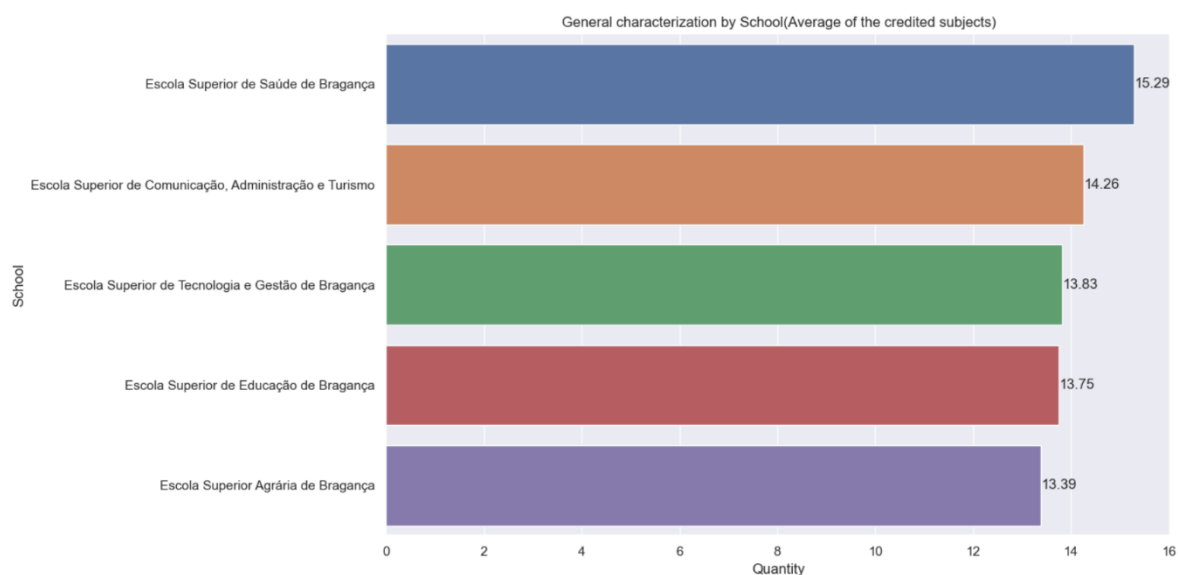

Figure 16: General characterization by School (Average of the credited subjects)

The bar chart below shows the average number of the credited subjects in different schools. The Y-axis represents schools, and the X-axis represents the average value. The highest average score was in ESSa at 15.29, and the lowest average score was in ESAa at 13.29.

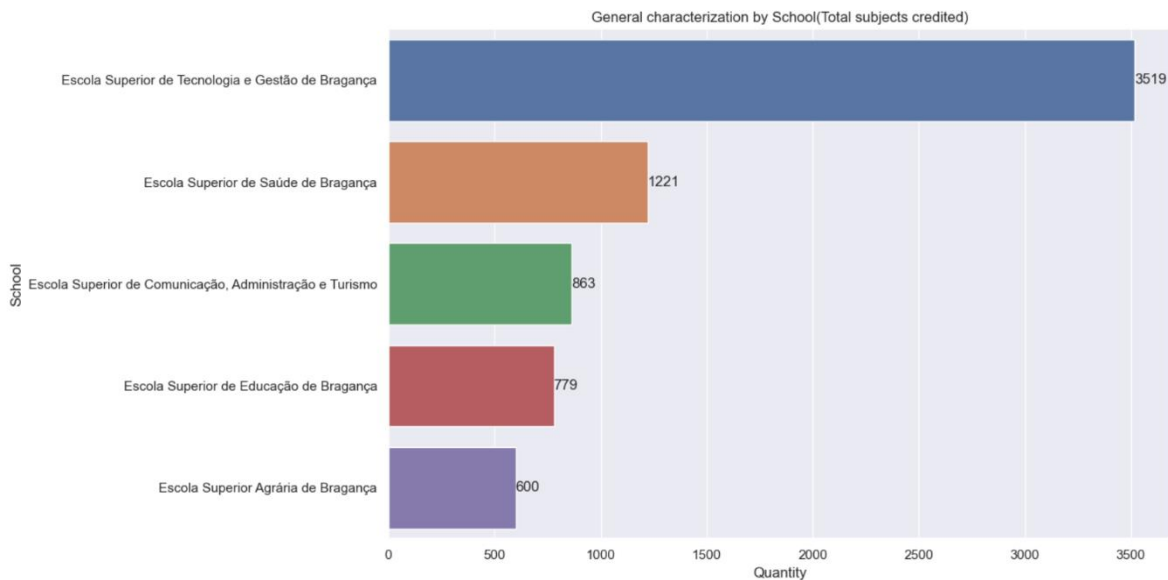

Figure 17: General characterization by School (Total subjects credited)

The bar chart below shows the total subjects credited in different schools. The Y-axis represents schools, and the X-axis represents the total value. The highest total score was in ESTiG at 3519, and the lowest total score was in ESAa at 600.

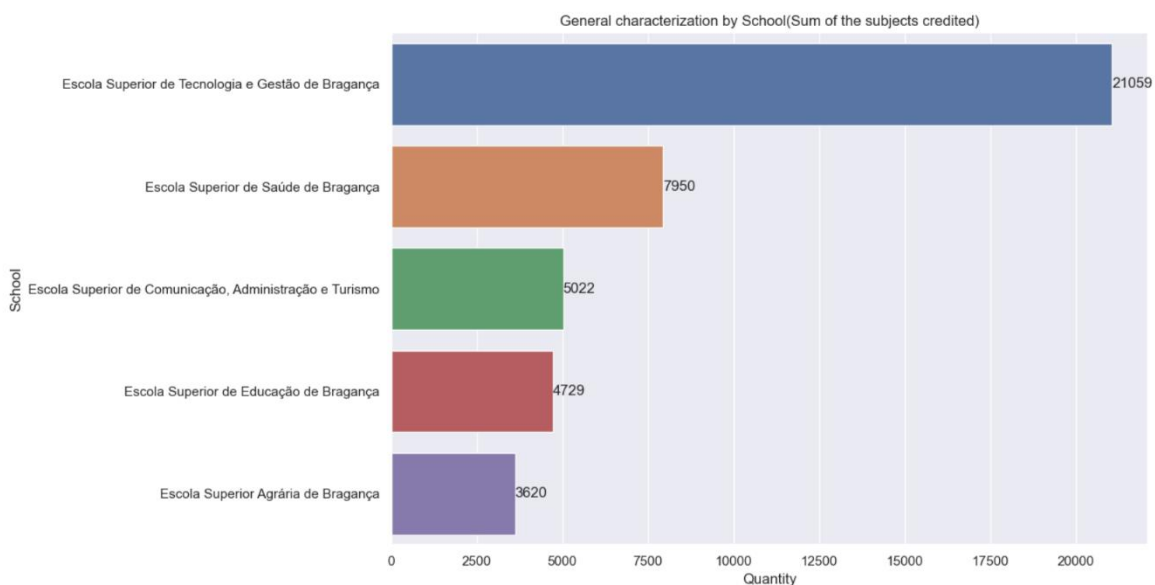

Figure 18: General characterization by School (Sum of the subjects credited)

The bar chart below shows the sum of the subjects credited in different schools. The Y-axis represents schools, and the X-axis represents the total value. The highest total score was in ESTiG at 21059, and the lowest total score was in ESAat 3620.

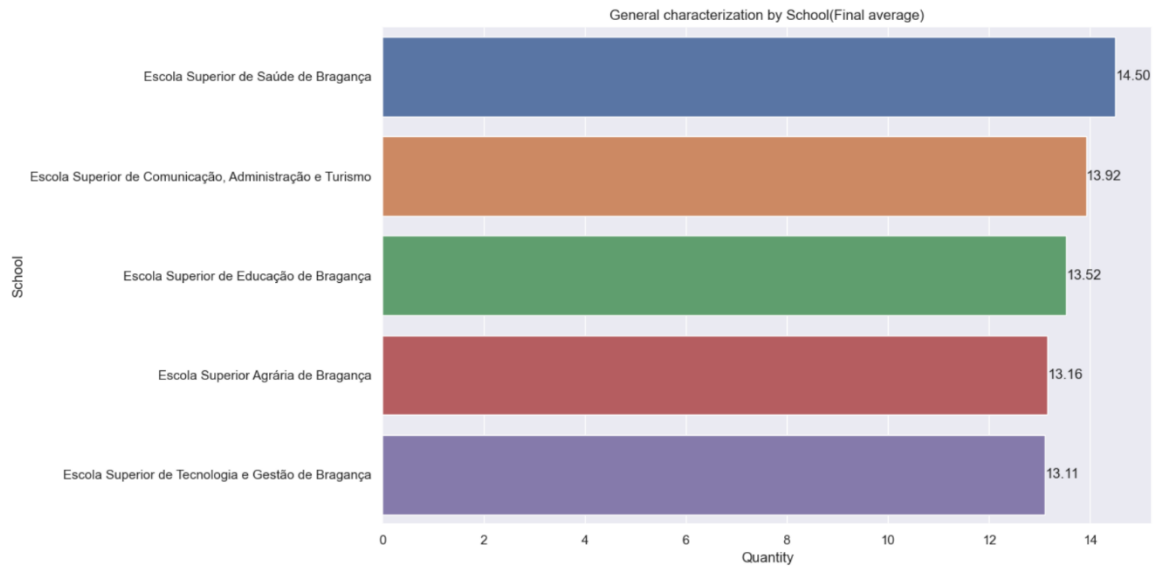

Figure 19: General characterization by School (Final average)

The bar chart below shows the final average in different schools. The Y-axis represents schools, and the X-axis represents the average value. The highest average score was in ESSA at 14.50, and the lowest average score was in ESTiG at 13.11.

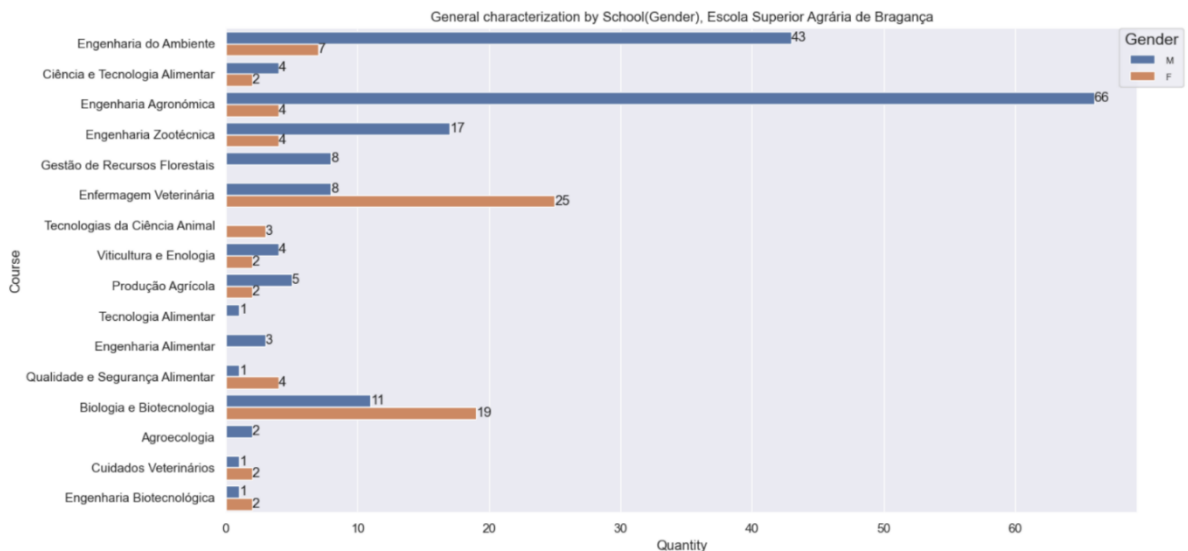

Figure 20: General characterization by School and Course (Gender), ESA

The bar chart below shows the number of students (male and female) studying in different courses. The Y-axis represents courses, and the X-axis represents the number of students.

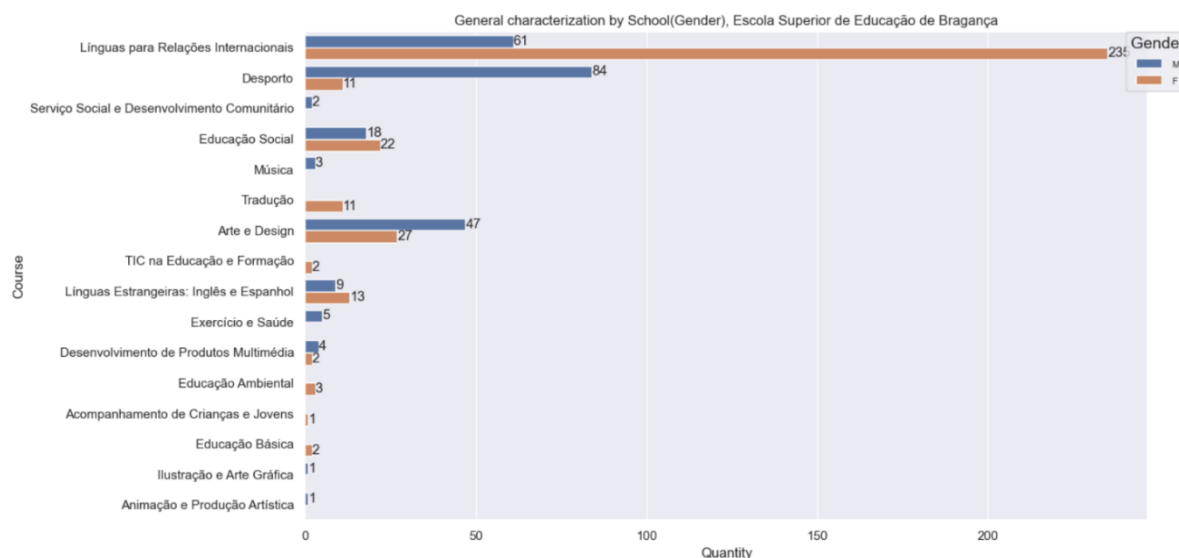

Figure 21: General characterization by School and Course (Gender), ESE

The bar chart below shows the number of students (male and female) studying in different courses. The Y-axis represents courses, and the X-axis represents the number of students.

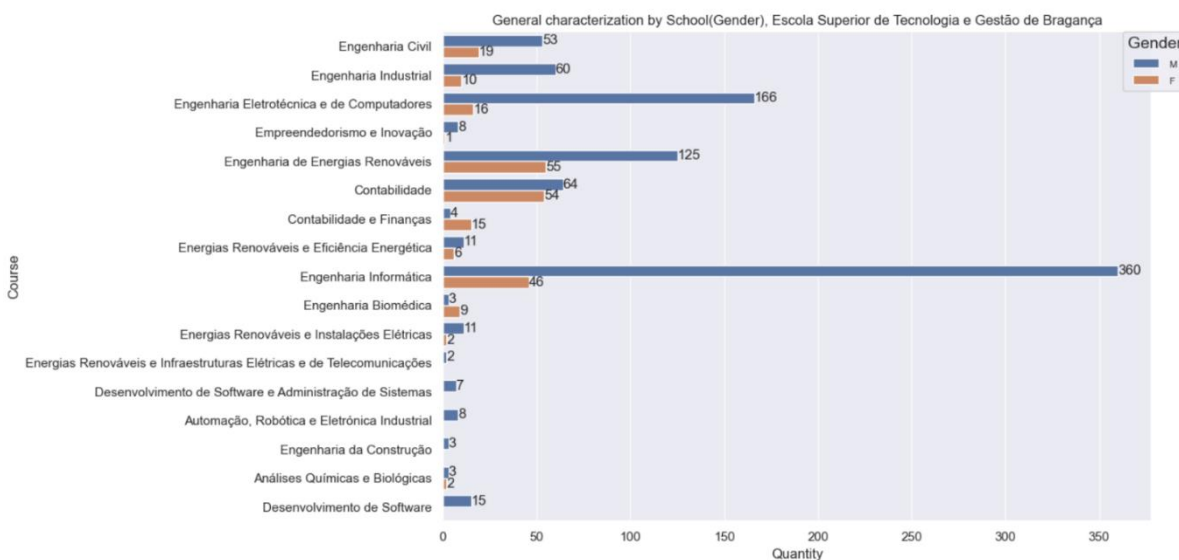

Figure 22: General characterization by School and Course (Gender), ESTiG (1st part)

The bar chart below shows the number of students (male and female) studying in different courses. The Y-axis represents courses, and the X-axis represents the number of students.

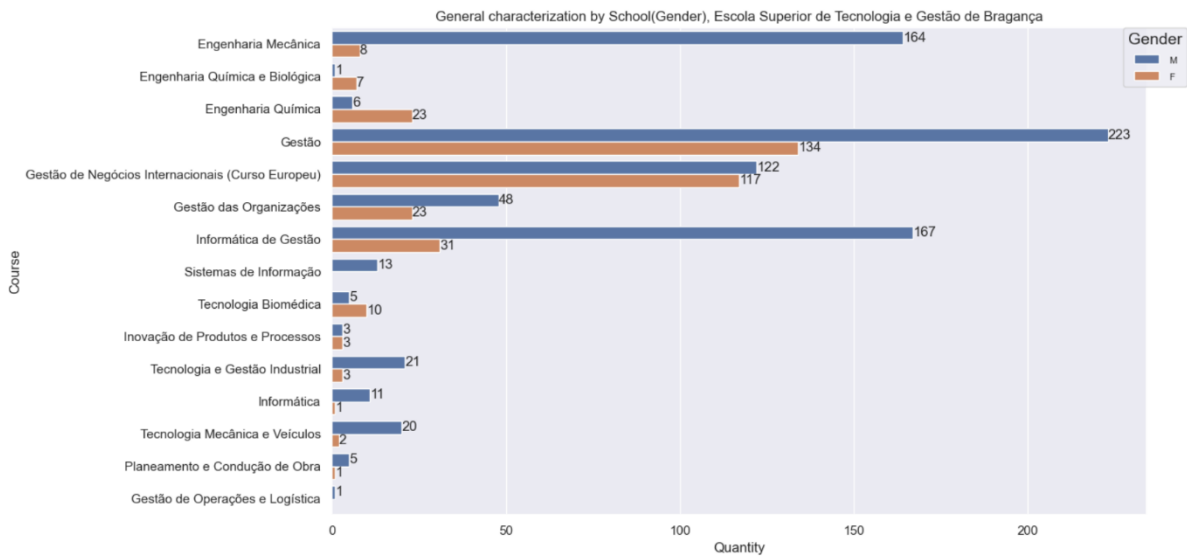

Figure 23: General characterization by School and Course (Gender), ESTiG (2nd part)

The bar chart below shows the number of students (male and female) studying in different courses. The Y-axis represents courses, and the X-axis represents the number of students.

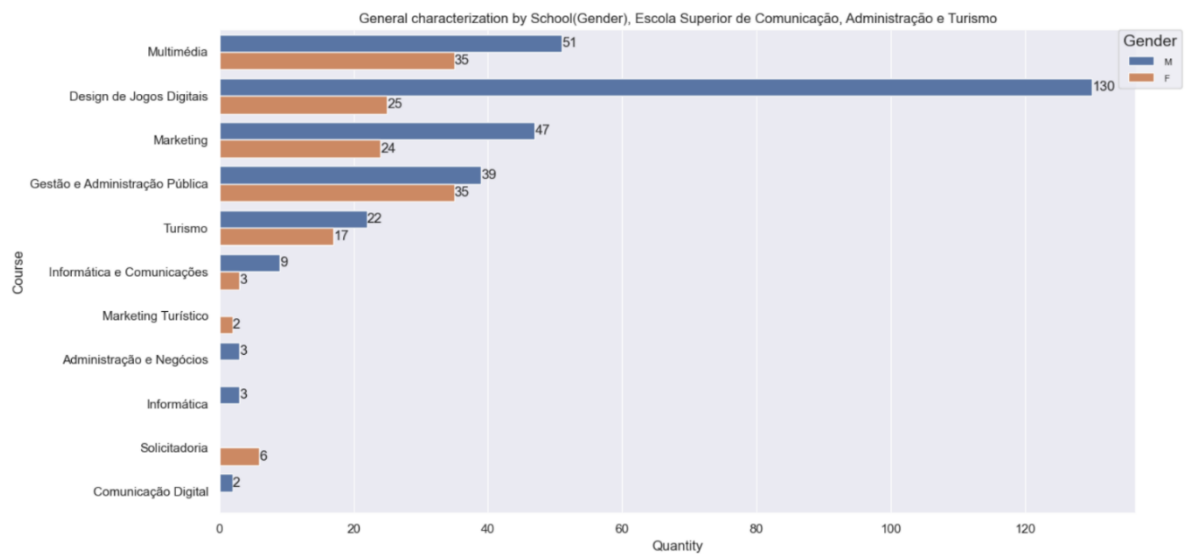

Figure 24: General characterization by School and Course (Gender), EsACT

The bar chart below shows the number of students (male and female) studying in different courses. The Y-axis represents courses, and the X-axis represents the number of students.

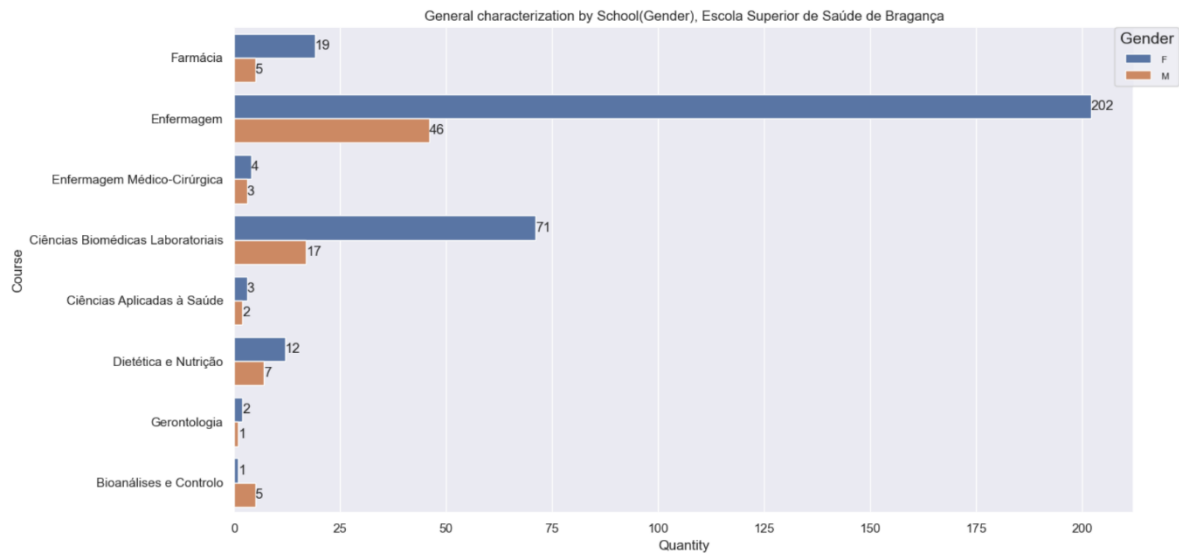

Figure 25: General characterization by School and Course (Gender), ESSa

The bar chart below shows the number of students (male and female) studying in different courses. The Y-axis represents courses, and the X-axis represents the number of students.

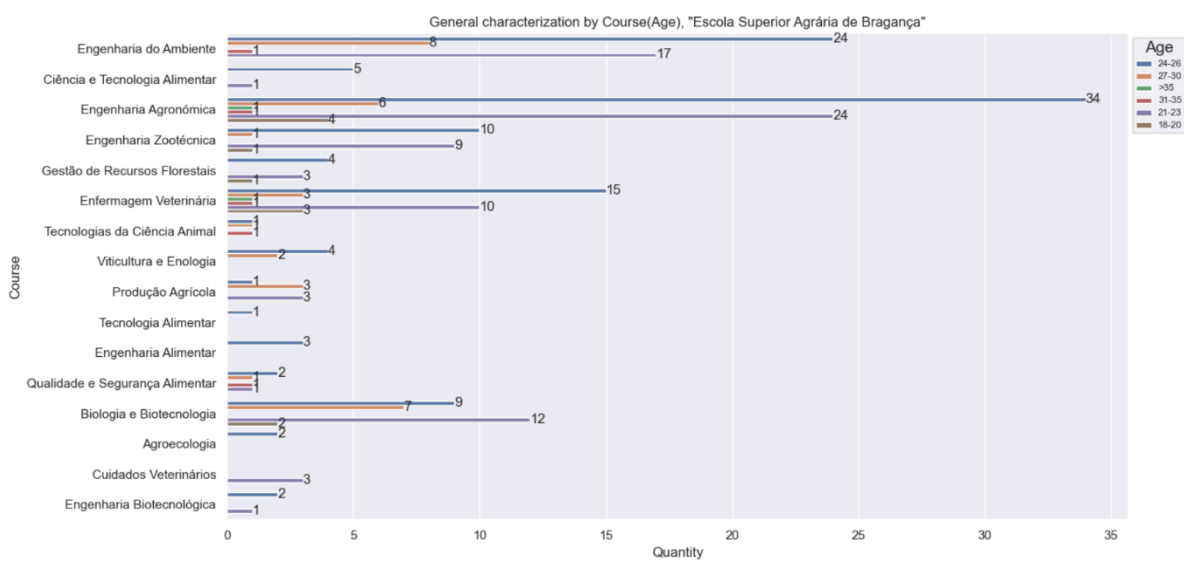

Figure 26: General characterization by School and Course (Age), ESA

The bar chart below shows the number of students of different ages studying in different courses. The Y-axis represents courses, and the X-axis represents the number of students. We can use this graph to build a list of student ages according to the number of students in descending order: 1)Students 24-26 years' old; 2)Students 21-23 years' old; 3)Students 27-30 years' old; 4)Students 18-20 years' old; 5)Students 31-35 years' old; 6)Students >35 years' old.

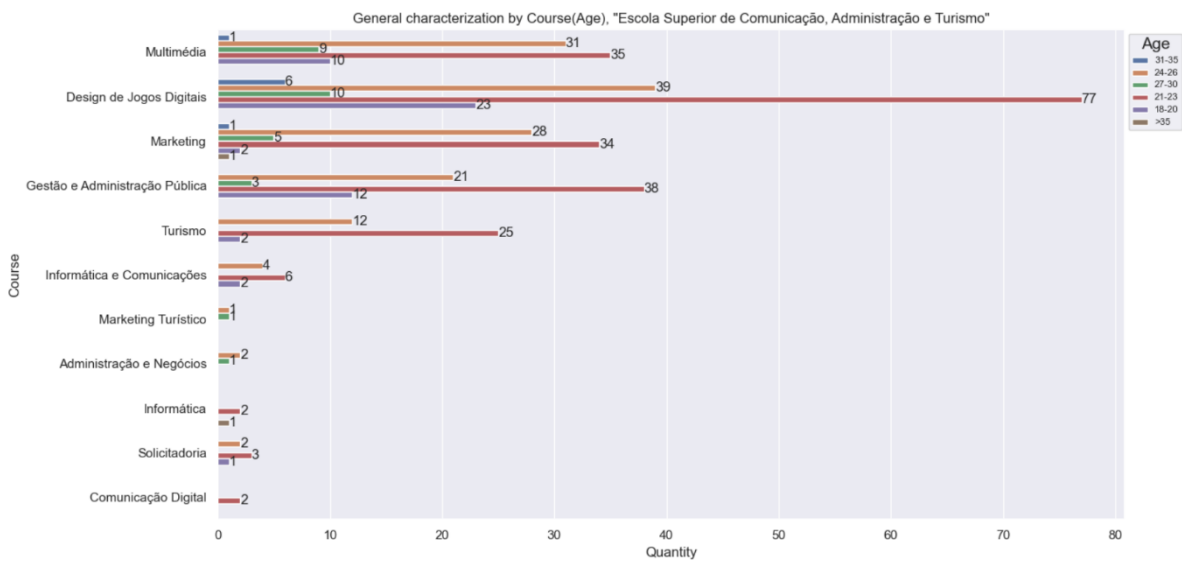

Figure 27: General characterization by School and Course (Age), EsACT

The bar chart below shows the number of students of different ages studying in different courses. The Y-axis represents courses, and the X-axis represents the number of students. We can use this graph to build a list of student ages according to the number of students in descending order: 1)Students 21-23 years' old; 2)Students 24-26 years' old; 3)Students 18-20 years' old; 4)Students 31-35 years' old; 5)Students 27-30 years' old; 6)Students >35 years' old.

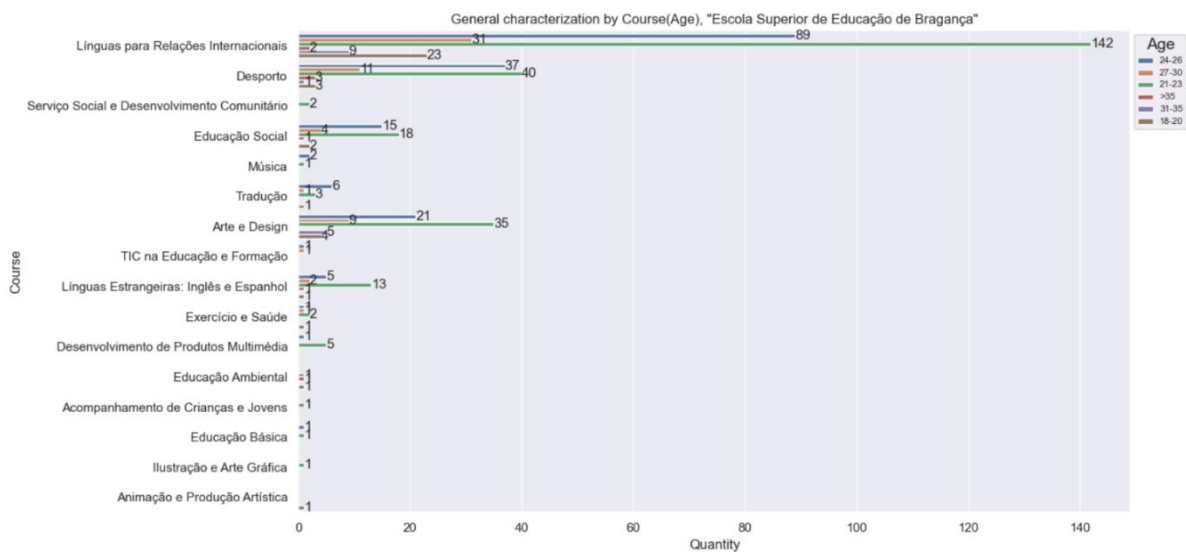

Figure 28: General characterization by School and Course (Age), ESE

The bar chart below shows the number of students of different ages studying in different courses. The Y-axis represents courses, and the X-axis represents the number of students. We can use this graph to build a list of student ages according to the number of students in descending order: 1)Students 21-23 years’ old; 2)Students 24-26 years’ old; 3)Students 27-30 years’ old; 4)Students 18-20 years’ old; 5)Students 31-35 years’ old; 6)Students >35 years’ old.

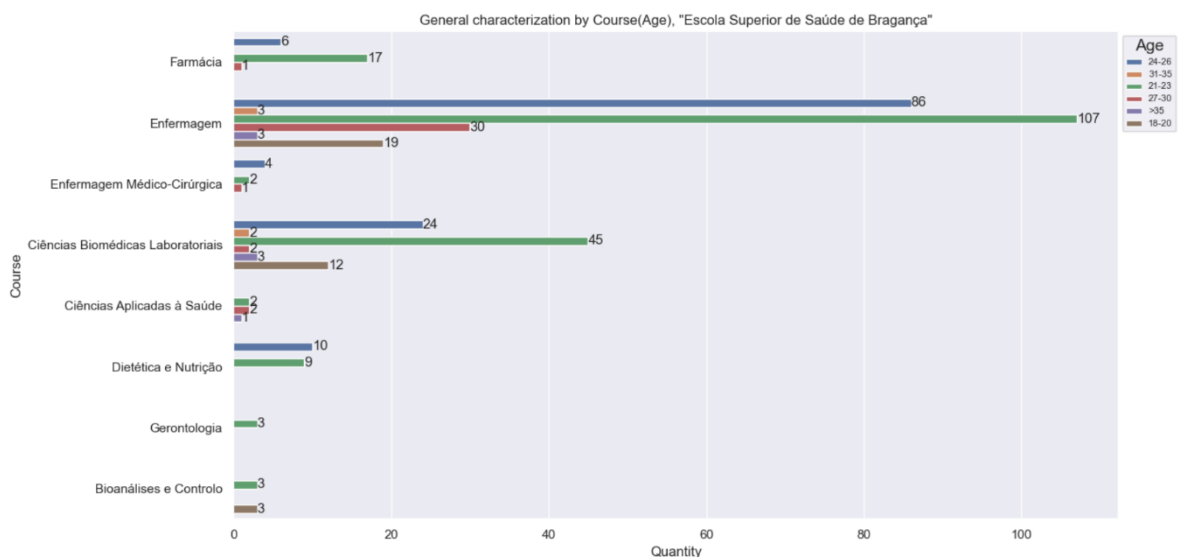

Figure 29: General characterization by School and Course (Age), ESSa

The bar chart below shows the number of students of different ages studying in different courses. The Y-axis represents courses, and the X-axis represents the number of students. We can use this graph to build a list of student ages according to the number of students in descending order: 1)Students 21-23 years' old; 2)Students 24-26 years' old; 3)Students 27-30 years' old; 4)Students 18-20 years' old; 5)Students >35 years' old; 6)Students 31-35 years' old.

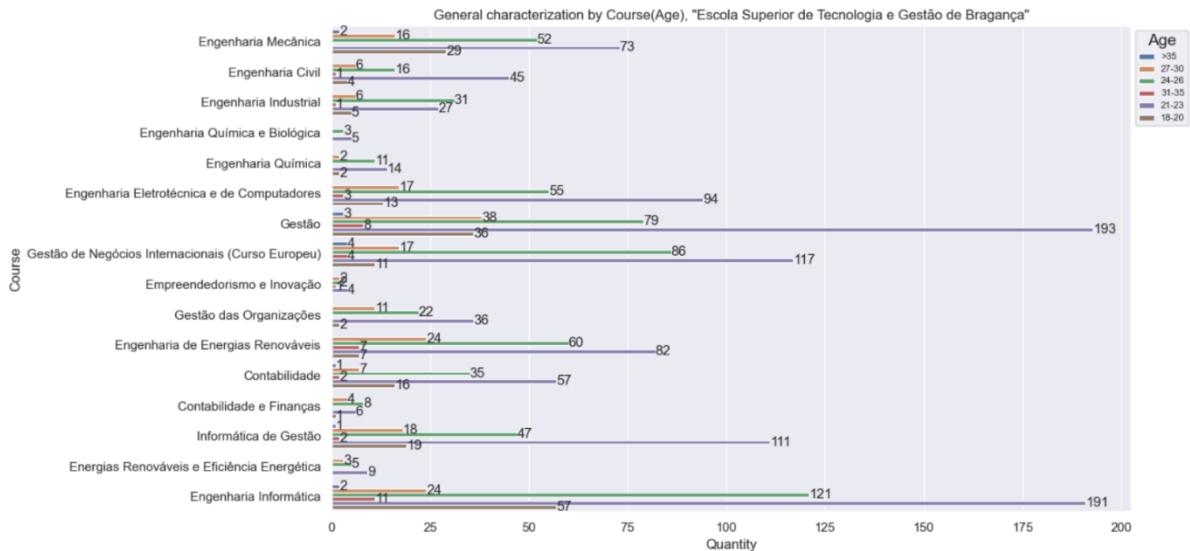

Figure 30: General characterization by School and Course (Age), ESTiG (1st part)

The bar chart below shows the number of students of different ages studying in different courses. The Y-axis represents courses, and the X-axis represents the number of students.

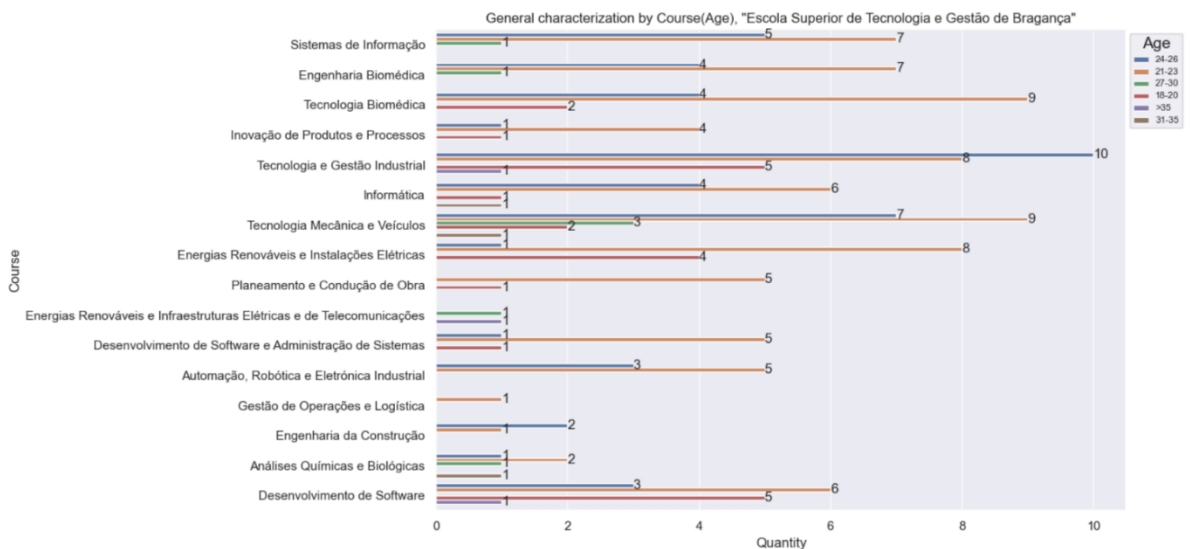

Figure 31: General characterization by School and Course (Age), ESTiG (2nd part)

The bar chart below shows the number of students of different ages studying in different courses. The Y-axis represents courses, and the X-axis represents the number of students. We can use this graph to build a list of student ages according to the number of students in descending order: 1)Students 21-23 years' old; 2)Students 24-26 years' old; 3)Students 27-30 years' old; 4)Students 18-20 years' old; 5)Students 31-35 years' old; 6)Students >35 years' old.

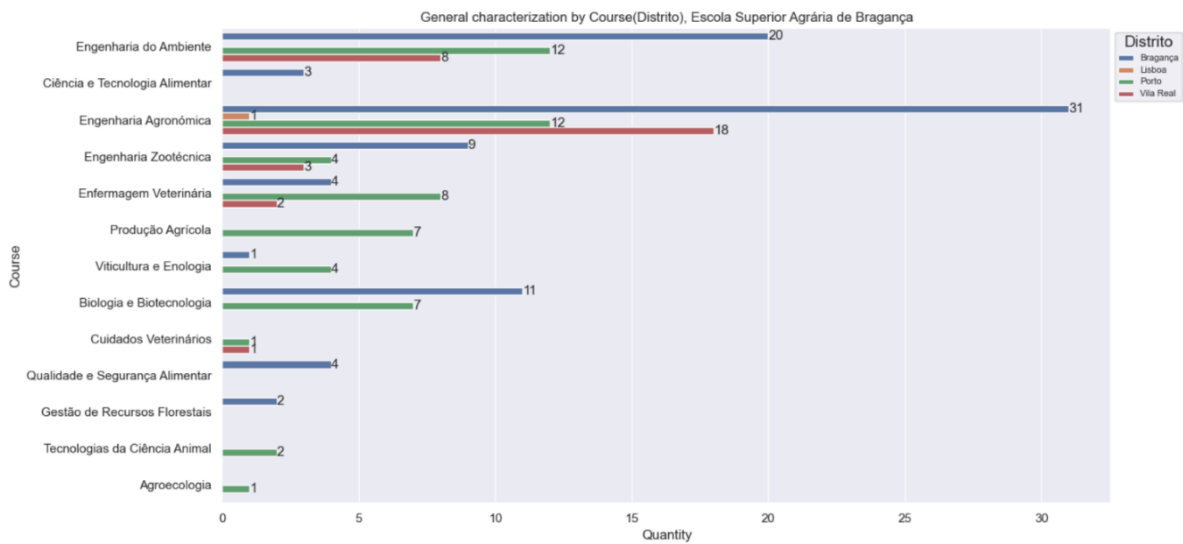

Figure 32: General characterization by School and Course (Distrito), ESA

The bar chart below shows the number of students from different districts in different courses. The Y-axis represents courses, and the X-axis represents the number of students. The most popular districts are: Bragança, Vila Real, Lisbon and Porto.

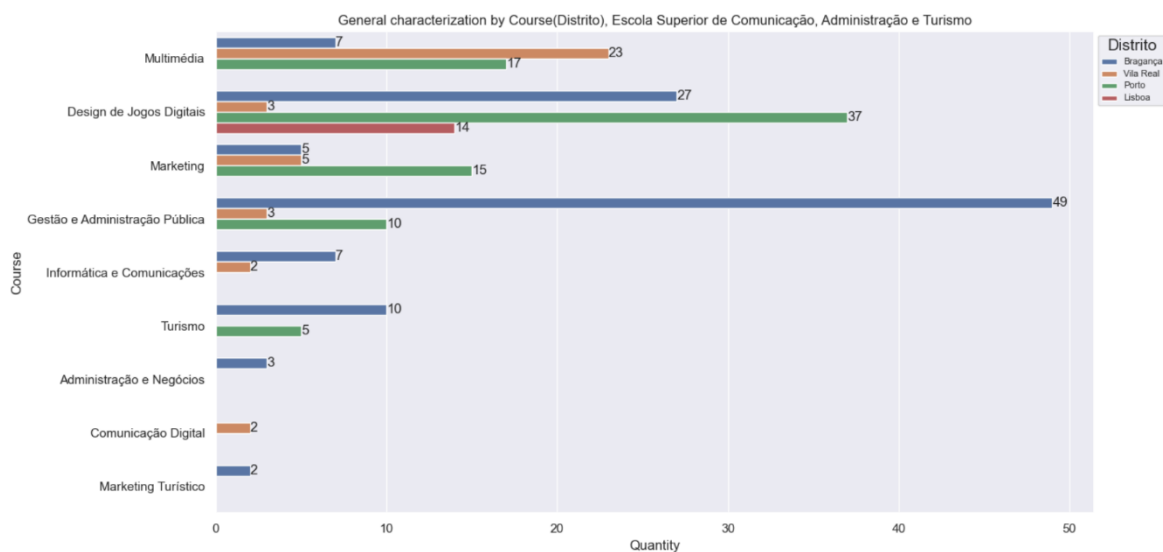

Figure 33: General characterization by School and Course (Distrito), EsACT

The bar chart below shows the number of students from different districts in different courses. The Y-axis represents courses, and the X-axis represents the number of students.

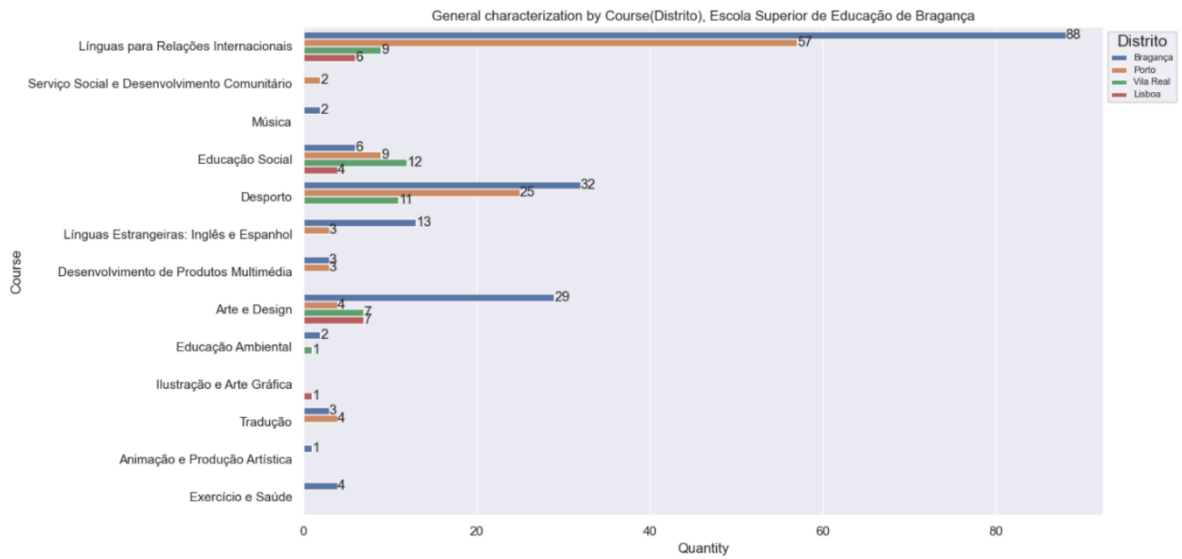

Figure 34: General characterization by School and Course (Distrito), ESE

The bar chart below shows the number of students from different districts in different courses. The Y-axis represents courses, and the X-axis represents the number of students.

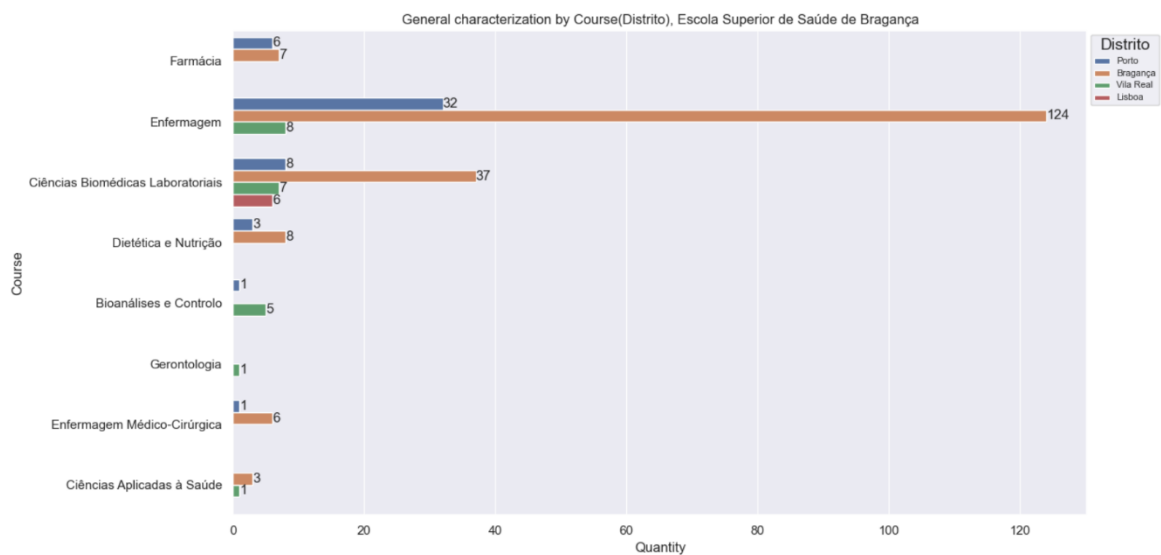

Figure 35: General characterization by School and Course (Distrito), ESSa

The bar chart below shows the number of students from different districts in different courses. The Y-axis represents courses, and the X-axis represents the number of students.

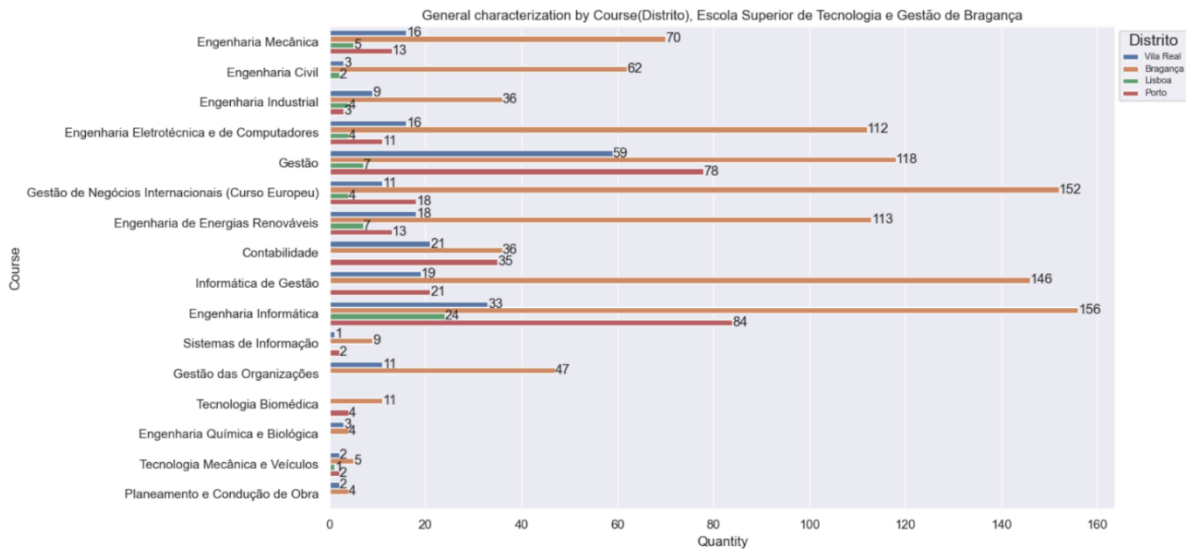

Figure 36: General characterization by School and Course (Distrito), ESTiG (1st part)

The bar chart below shows the number of students from different districts in different courses. The Y-axis represents courses, and the X-axis represents the number of students.

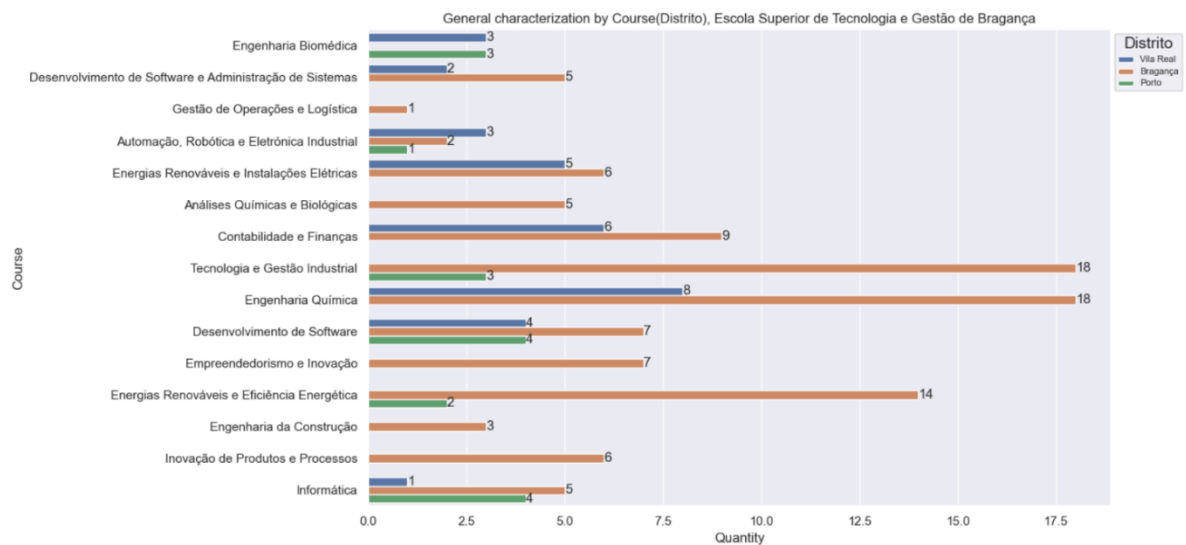

Figure 37: General characterization by School and Course (Distrito), ESTiG (2ns part)

The bar chart below shows the number of students from different districts in different courses. The Y-axis represents courses, and the X-axis represents the number of students. Below are the top Concelho from each District.

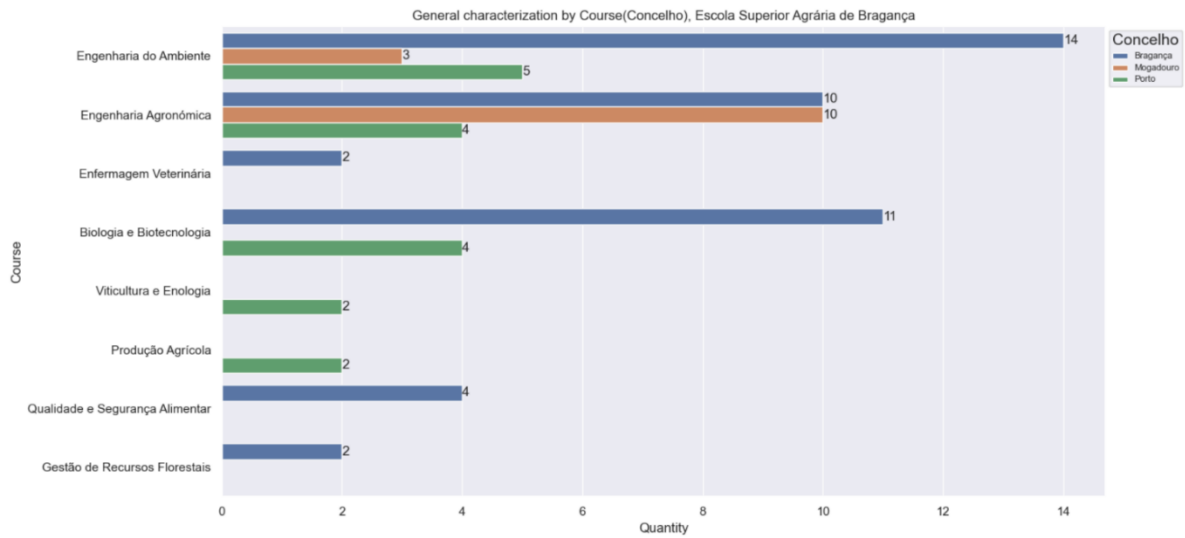

Figure 38: General characterization by School and Course (Concelho), ESA

The bar chart below shows the number and percent of students from top regions districts in different courses. The Y-axis represents courses, and the X-axis represents the number of students.

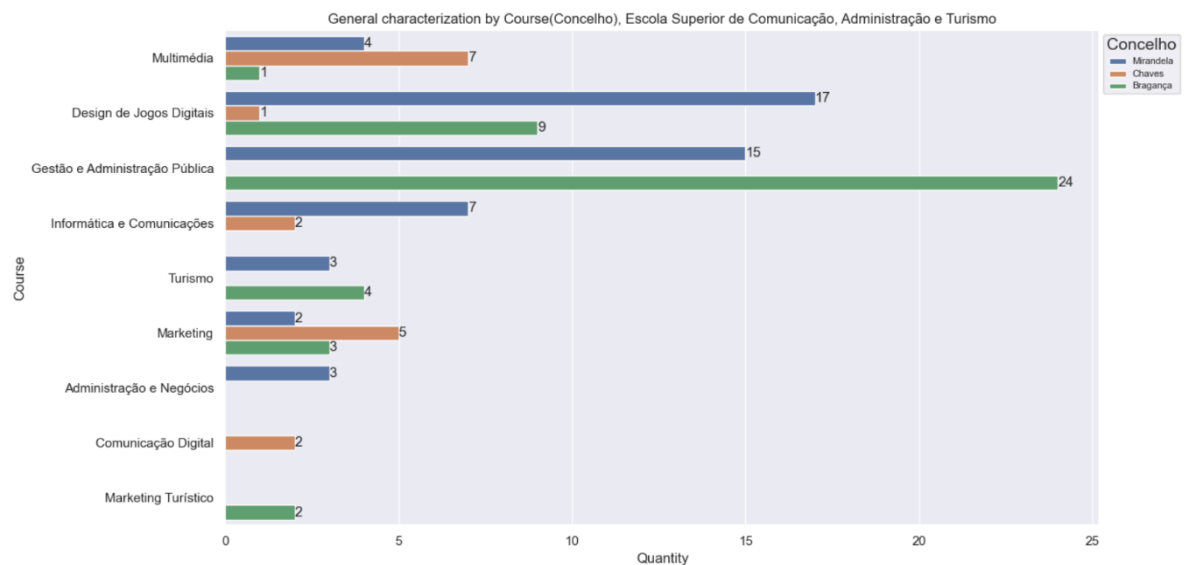

Figure 39: General characterization by School and Course (Concelho), EsACT

The bar chart below shows the number and percent of students from top regions districts in different courses. The Y-axis represents courses, and the X-axis represents the number of students.

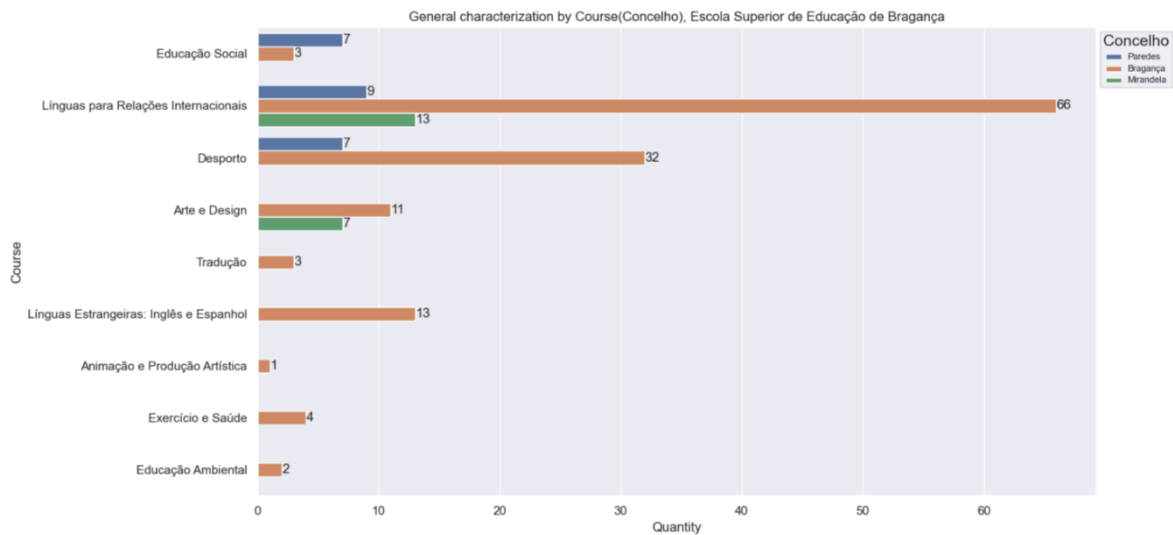

Figure 40: General characterization by School and Course (Concelho), ESE

The bar chart below shows the number and percent of students from top regions districts in different courses. The Y-axis represents courses, and the X-axis represents the number of students.

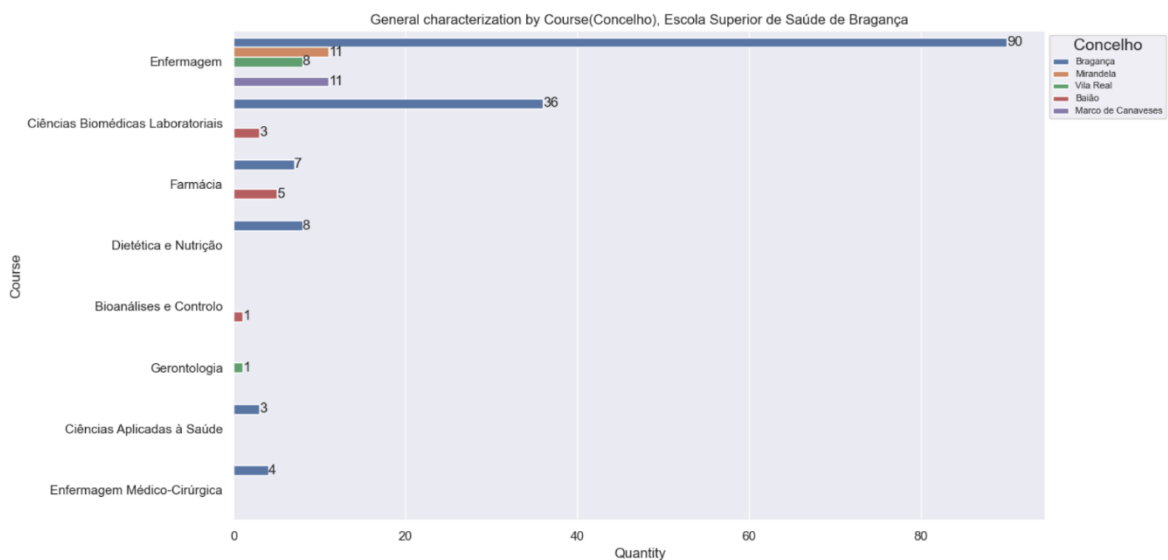

Figure 41: General characterization by School and Course (Concelho), ESSa

The bar chart below shows the number and percent of students from top regions districts in different courses. The Y-axis represents courses, and the X-axis represents the number of students.

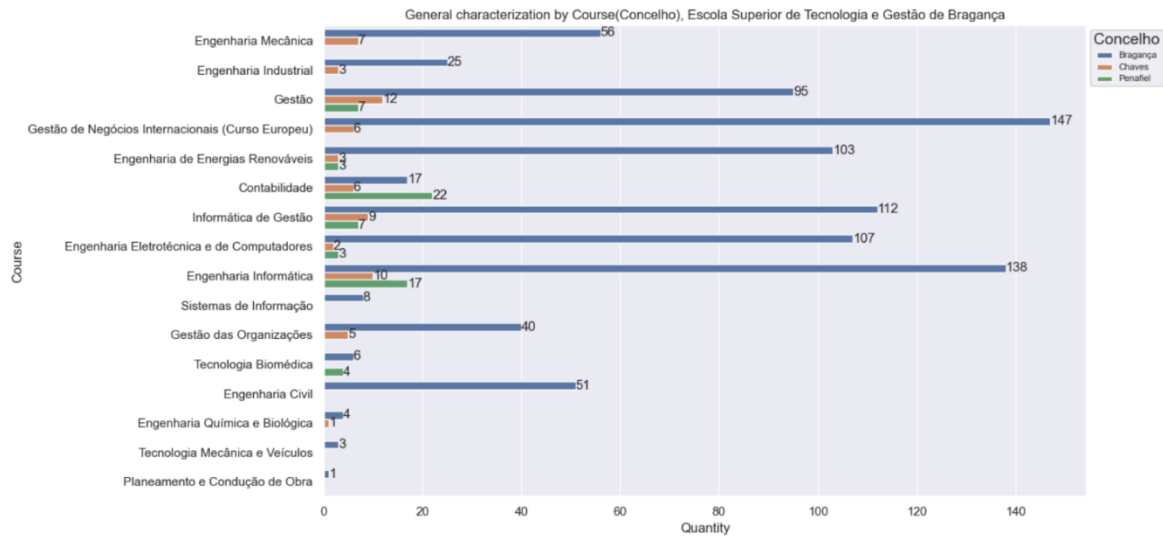

Figure 42: General characterization by School and Course (Concelho), ESTiG (1st part)

The bar chart below shows the number and percent of students from top regions districts in different courses. The Y-axis represents courses, and the X-axis represents the number of students.

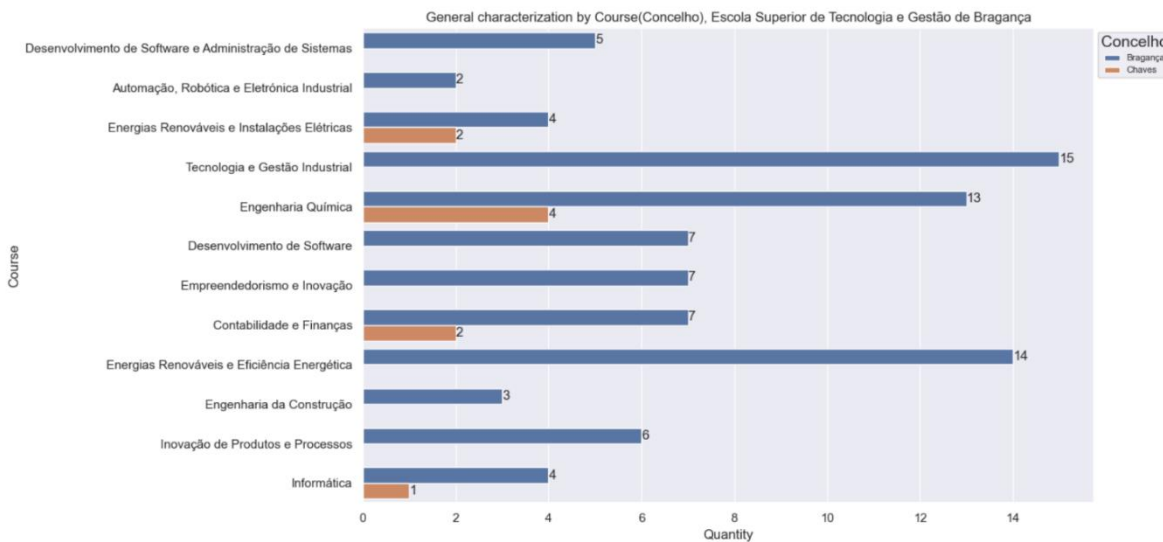

Figure 43: General characterization by School and Course (Concelho), ESTiG (2nd part)

The bar chart below shows the number and percent of students from top regions districts in different courses. The Y-axis represents courses, and the X-axis represents the number of students.

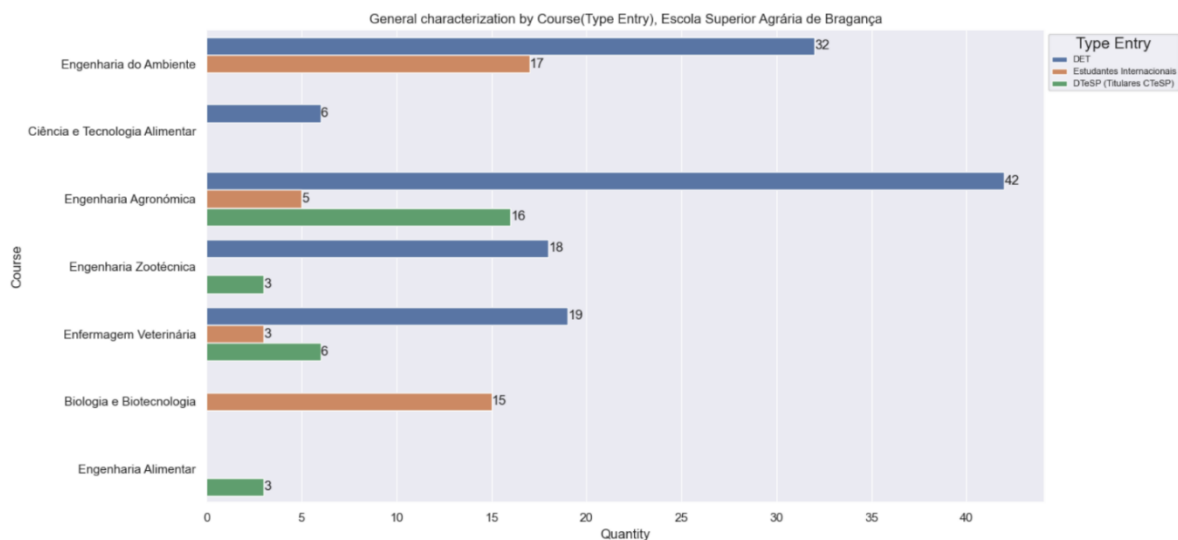

Figure 44: General characterization School and Course (Type Entry), ESA

The bar chart below shows the number and of students from top 3 different type entry in different courses. The Y-axis represents courses, and the X-axis represents the number of students.

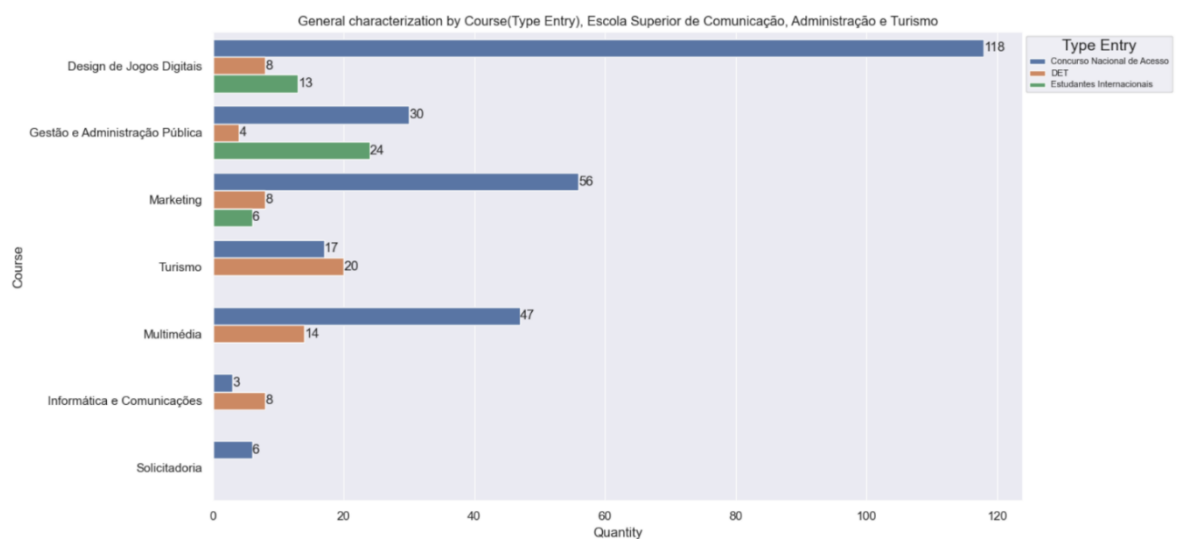

Figure 45: General characterization School and Course (Type Entry), EsACT

The bar chart below shows the number and of students from top 3 different type entry in different courses. The Y-axis represents courses, and the X-axis represents the number of students.

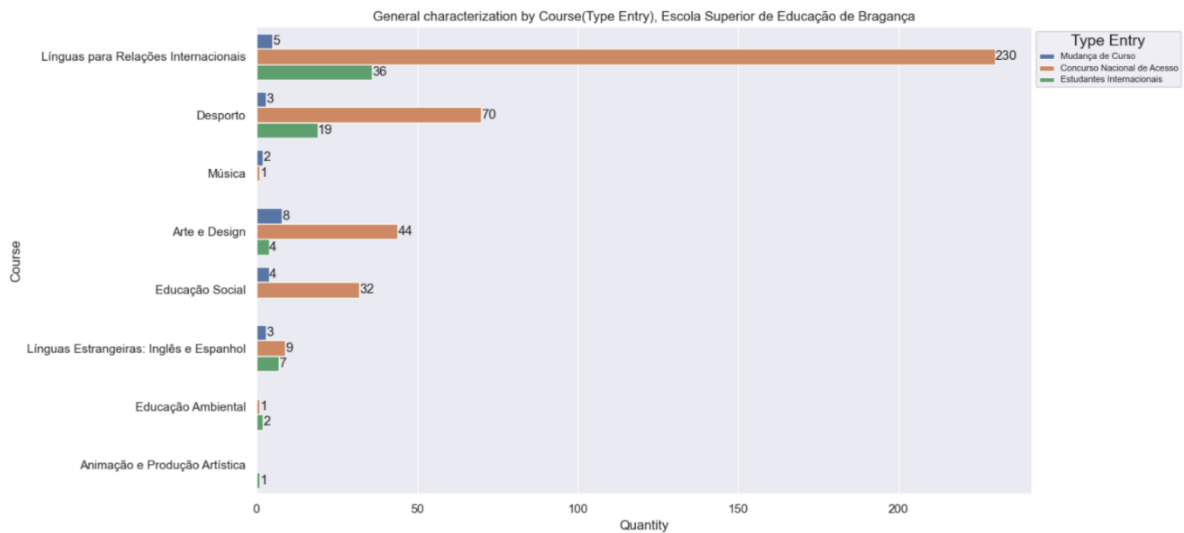

Figure 46: General characterization School and Course (Type Entry), ESE

The bar chart below shows the number and of students from top 3 different type entry in different courses. The Y-axis represents courses, and the X-axis represents the number of students.

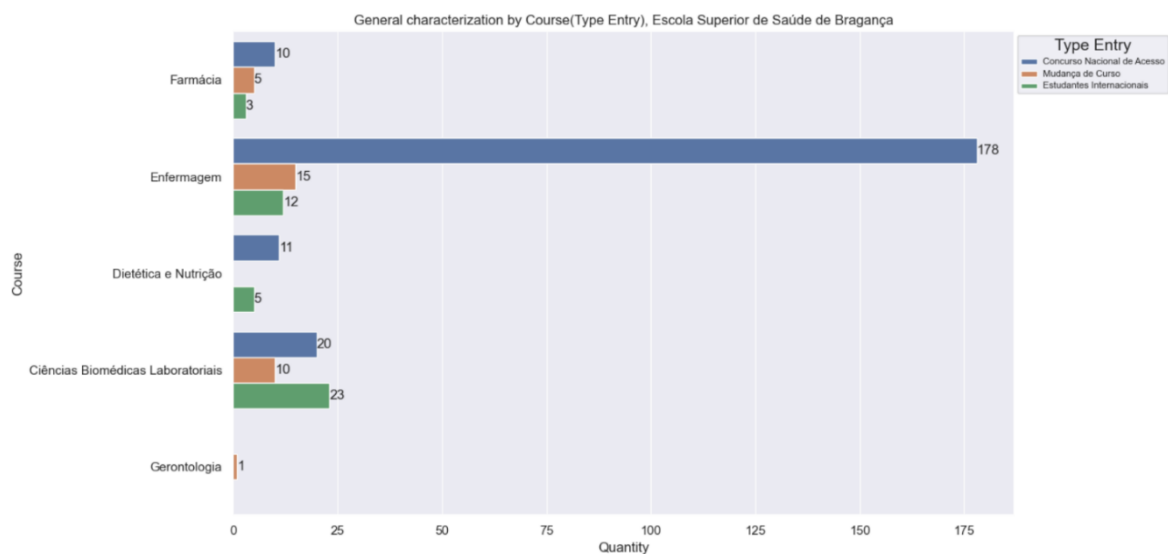

Figure 47: General characterization School and Course (Type Entry), ESSa

The bar chart below shows the number and of students from top 3 different type entry in different courses. The Y-axis represents courses, and the X-axis represents the number of students.

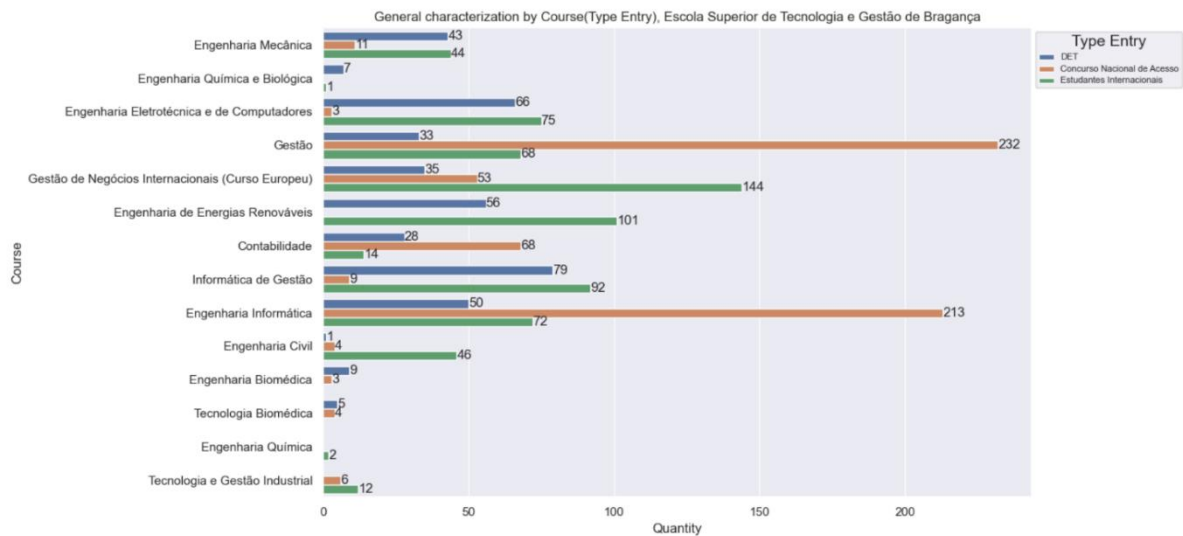

Figure 48: General characterization School and Course (Type Entry), ESTiG

The bar chart below shows the number and of students from top 3 different type entry in different courses. The Y-axis represents courses, and the X-axis represents the number of students.

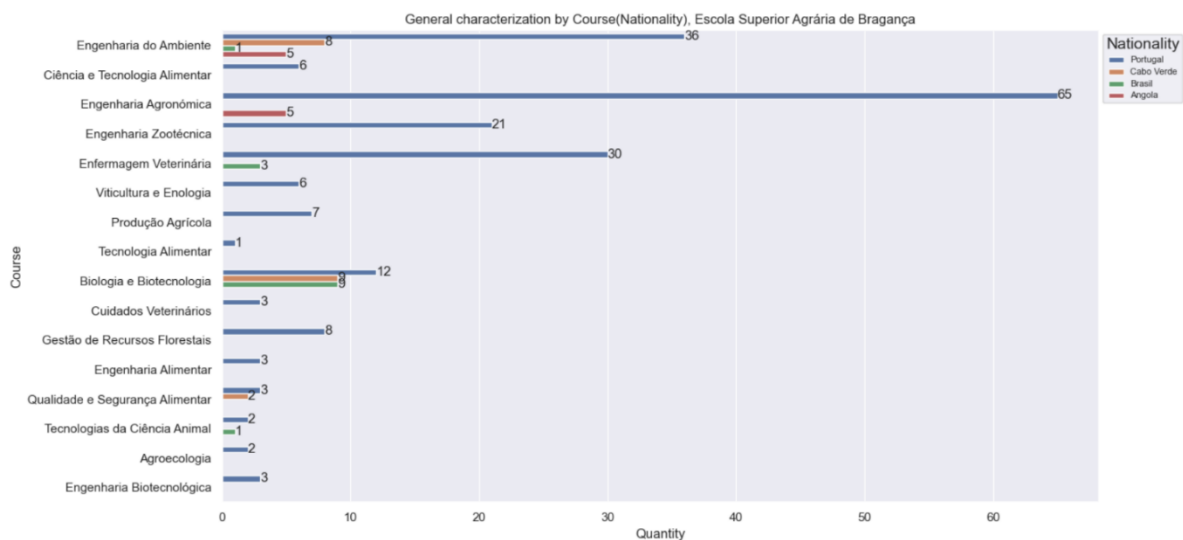

Figure 49: General characterization School and Course (Nationality), ESA

The bar chart below shows the number and percent of students of top nationalities in different courses. The Y-axis represents schools, and the X-axis represents the number of students.

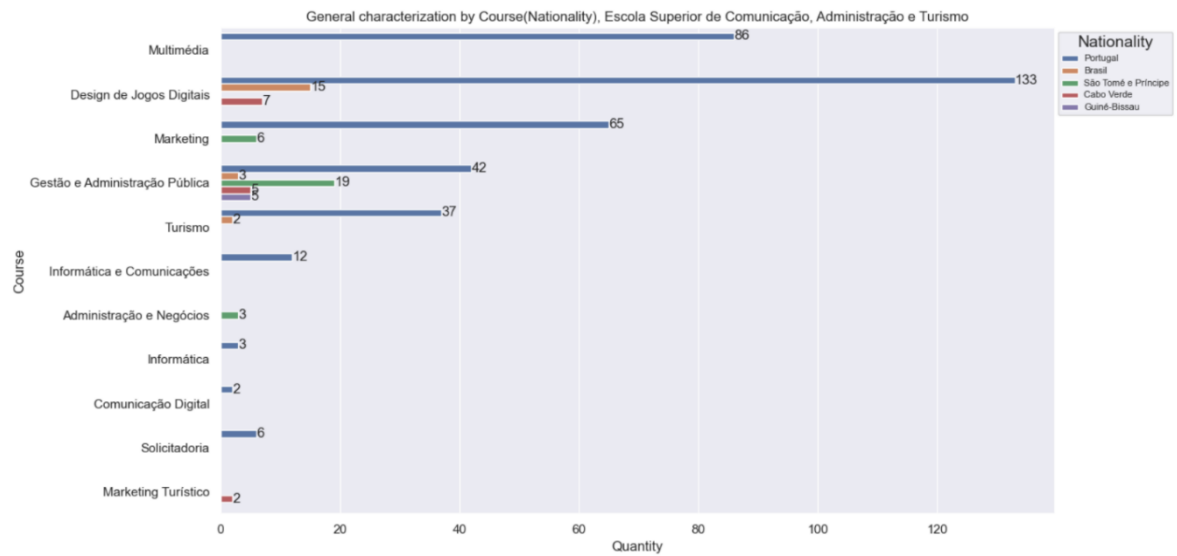

Figure 50: General characterization School and Course (Nationality), EsACT

The bar chart below shows the number and percent of students of top nationalities in different courses. The Y-axis represents schools, and the X-axis represents the number of students.

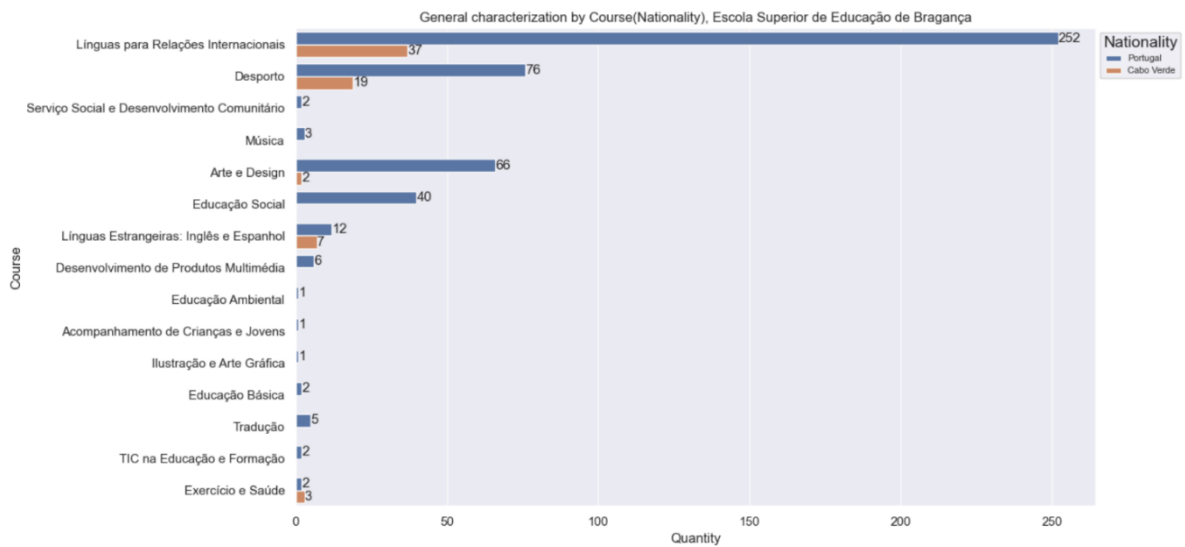

Figure 51: General characterization School and Course (Nationality), ESE

The bar chart below shows the number and percent of students of top nationalities in different courses. The X-axis represents schools, and the Y-axis represents the number of students.

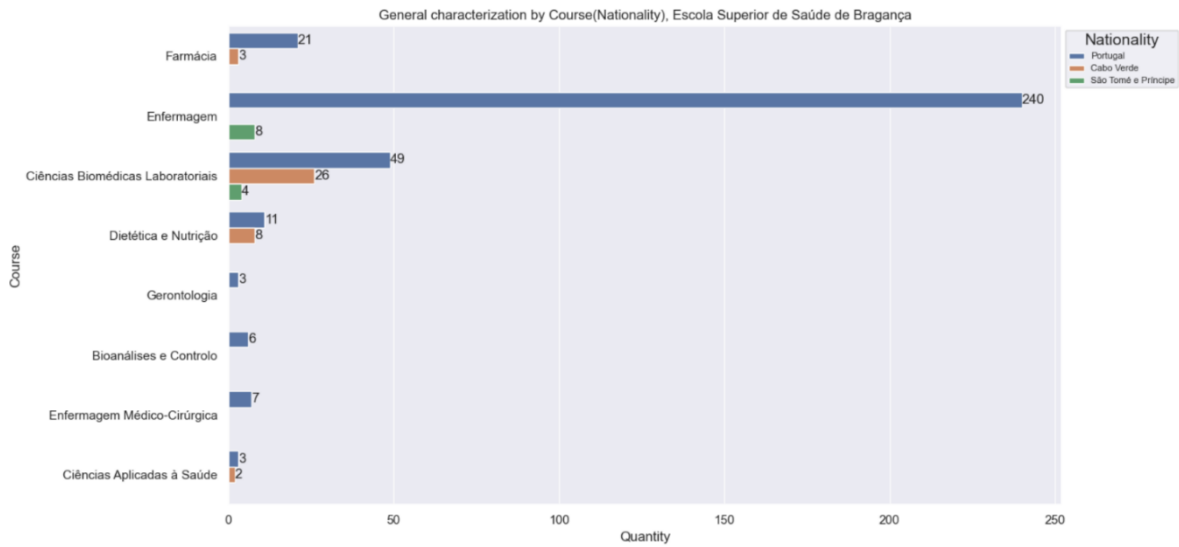

Figure 52: General characterization School and Course (Nationality), ESSa

The bar chart below shows the number and percent of students of top nationalities in different courses. The Y-axis represents schools, and the X-axis represents the number of students.

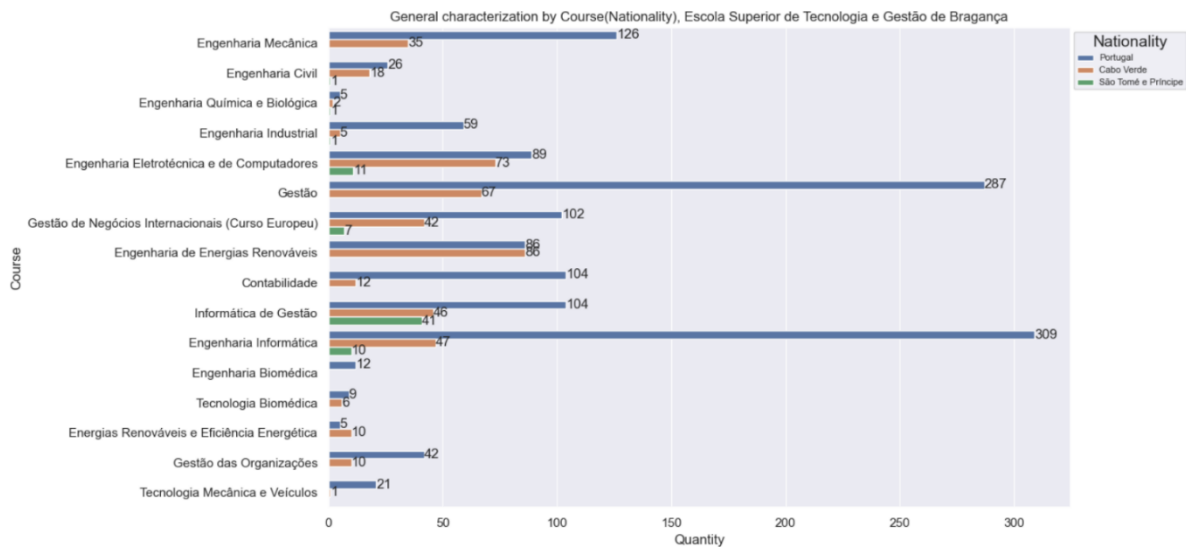

Figure 53: General characterization School and Course (Nationality), ESTiG (1st part)

The bar chart below shows the number and percent of students of top nationalities in different courses. The Y-axis represents schools, and the X-axis represents the number of students.

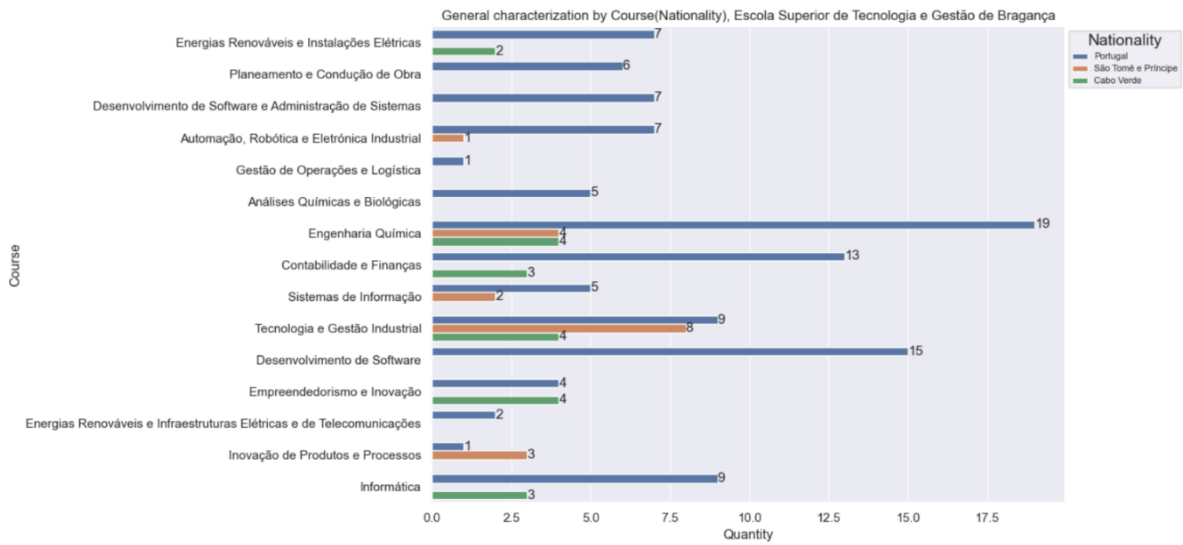

Figure 54: General characterization School and Course (Nationality), ESTiG (2nd part)

The bar chart below shows the number and percent of students of top nationalities in different courses. The Y-axis represents schools, and the X-axis represents the number of students.

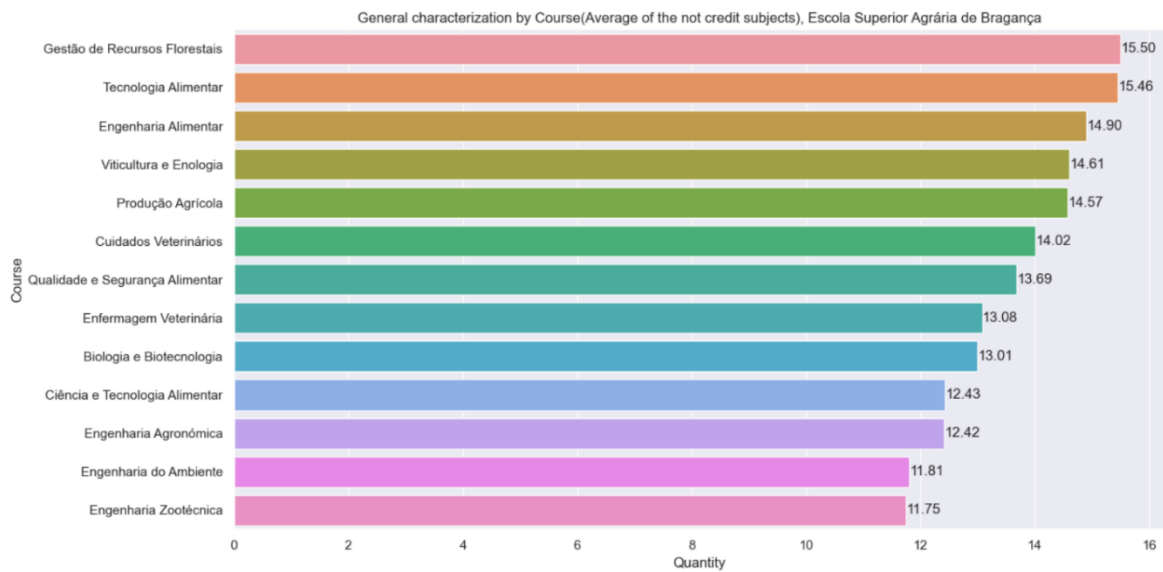

Figure 3.73: General characterization School and Course (Average of the not credit subjects), ESA

The bar chart below shows the average number of the not credit subjects in different courses. The Y-axis represents courses, and the X-axis represents the average value. The highest average score was in Gestão de Recursos Florestais at 15.50, and the lowest average score was in Engenharia Zootécnica at 11.75.

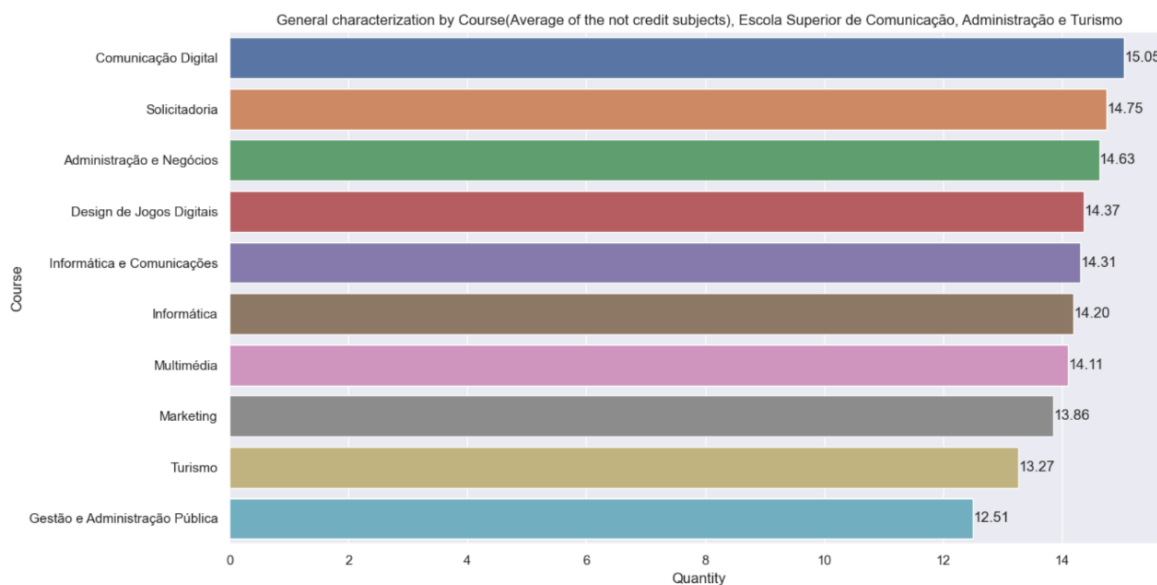

Figure 55: General characterization School and Course (Average of the not credit subjects), EsACT

The bar chart below shows the average number of the not credit subjects in different courses. The Y-axis represents courses, and the X-axis represents the average value. The highest average score was in Comunicação Digital at 15.05, and the lowest average score was in Gestão e Administração Pública at 12.51.

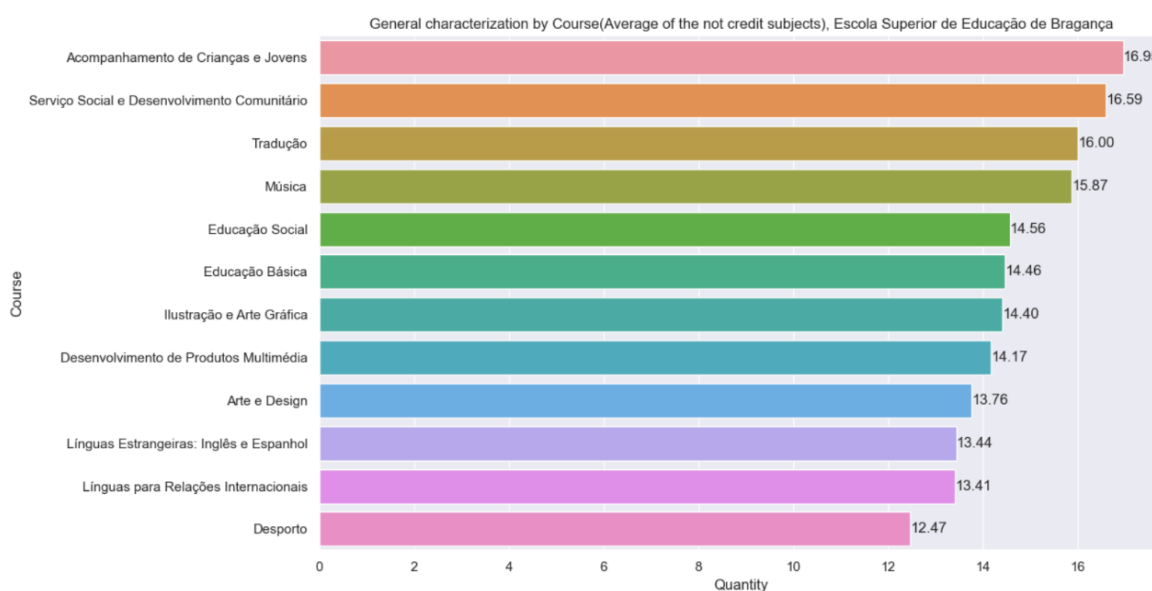

Figure 56: General characterization School and Course (Average of the not credit subjects), ESE

The bar chart below shows the average number of the not credit subjects in different courses. The Y-axis represents courses, and the X-axis represents the average value. The highest average score was in Acompanhamento de Crianças e Jovens at 16.95, and the lowest average score was in Desporto at 12.47.

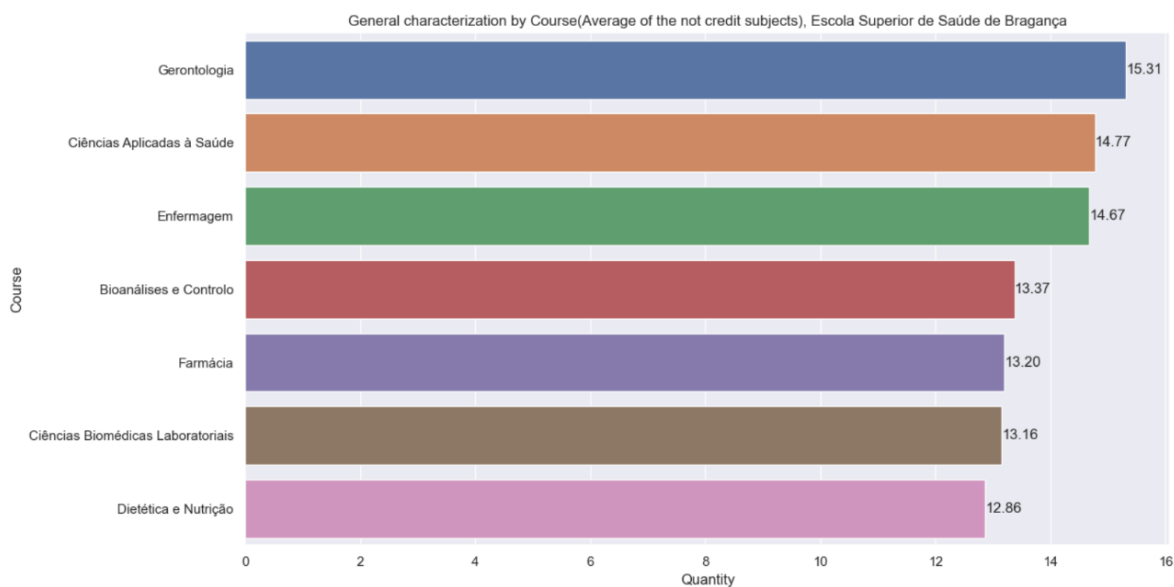

Figure 57: General characterization School and Course (Average of the not credit subjects), ESSa

The bar chart below shows the average number of the not credit subjects in different courses. The Y-axis represents courses, and the X-axis represents the average value. The highest average score was in Gerontologia at 15.31, and the lowest average score was in Dietética e Nutrição at 12.86.

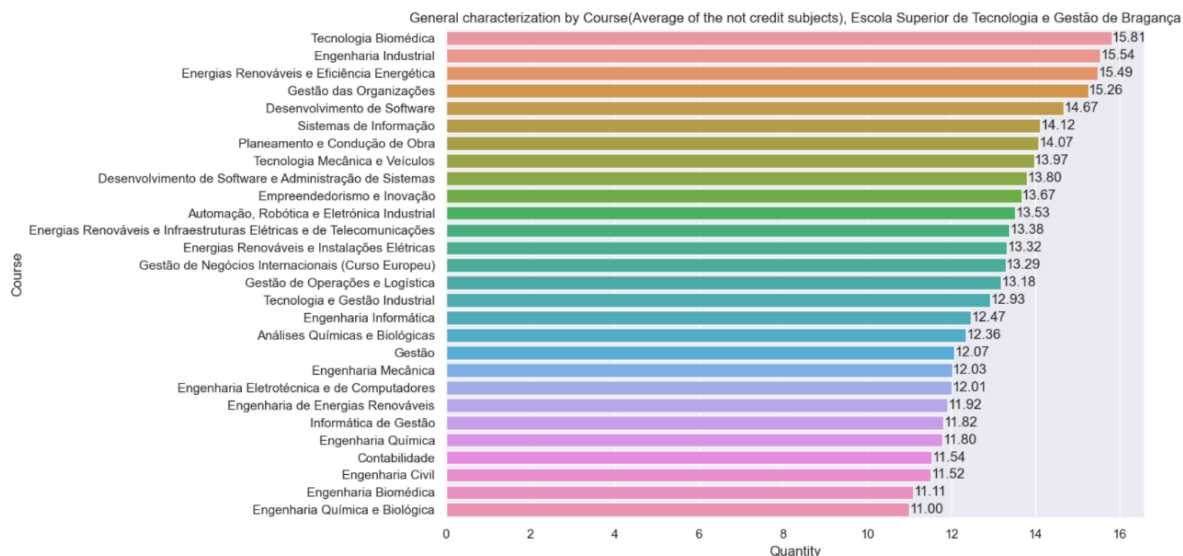

Figure 58: General characterization School and Course (Average of the not credit subjects), ESTiG

The bar chart below shows the average number of the not credit subjects in different courses. The Y-axis represents courses, and the X-axis represents the average value. The highest average score was in Tecnologia Biomédica at 15.81, and the lowest average score was in Engenharia Química e Biológica at 11.00.

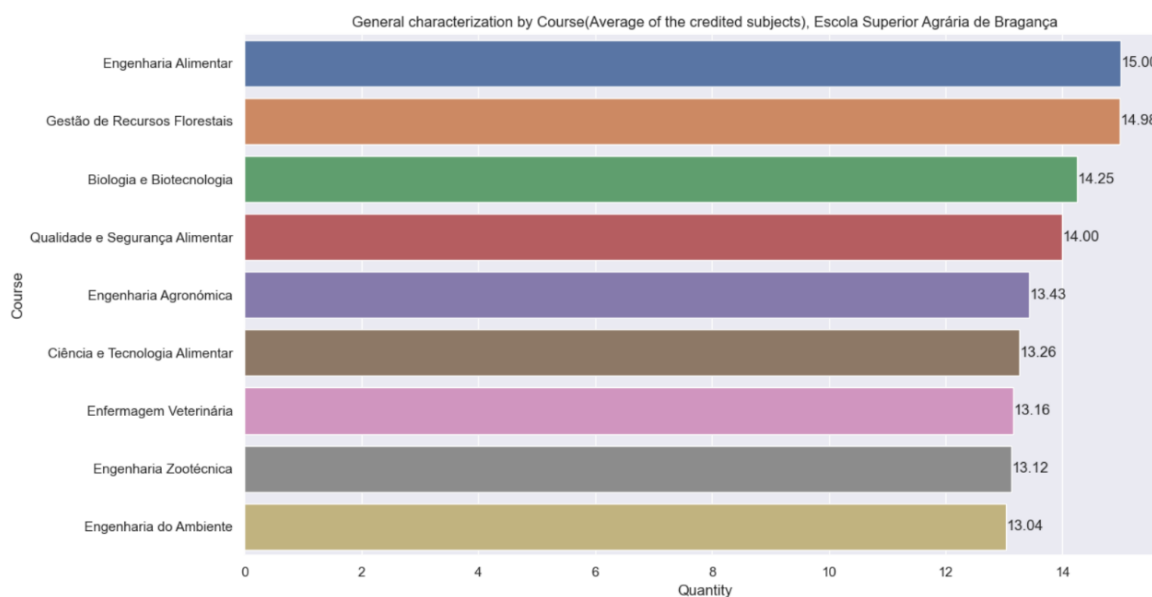

Figure 59: General characterization School and Course (Average of the credited subjects), ESA

The bar chart below shows the average number of the not credit subjects in different courses. The Y-axis represents courses, and the X-axis represents the average value. The highest average score was in Engenharia Alimentar at 15.00, and the lowest average score was in Engenharia do Ambiente at 13.04.

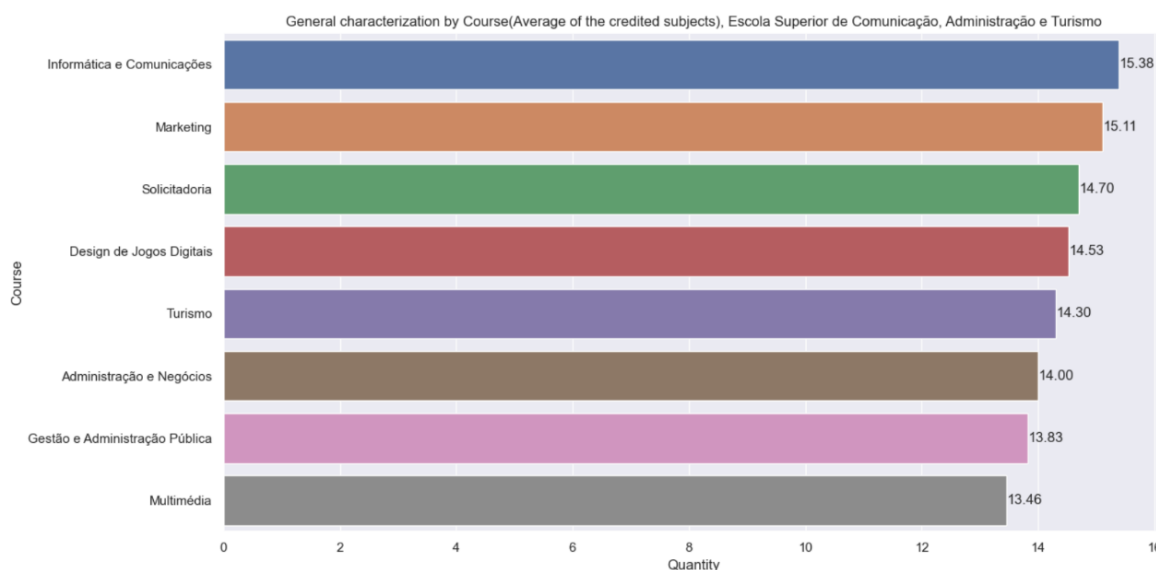

Figure 60: General characterization School and Course (Average of the credited subjects), EsACT

The bar chart below shows the average number of the not credit subjects in different courses. The Y-axis represents courses, and the X-axis represents the average value. The highest average score was in Informática e Comunicações at 15.38, and the lowest average score was in Multimédia at 13.46.

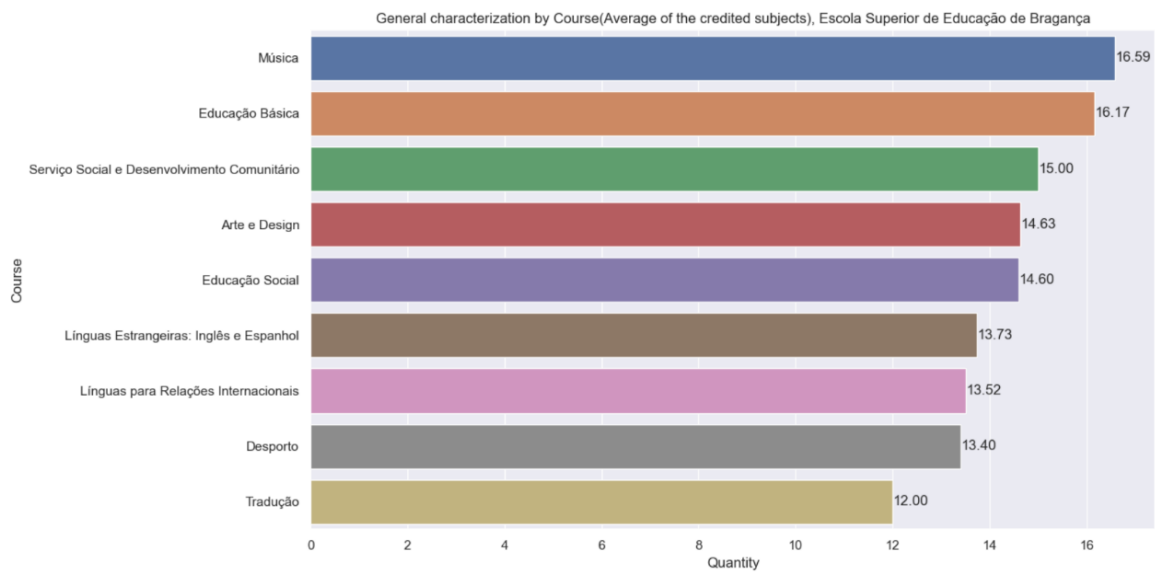

Figure 61: General characterization School and Course (Average of the credited subjects), ESE

The bar chart below shows the average number of the not credit subjects in different courses. The Y-axis represents courses, and the X-axis represents the average value. The highest average score was in Música at 16.59, and the lowest average score was in Tradução at 12.00.

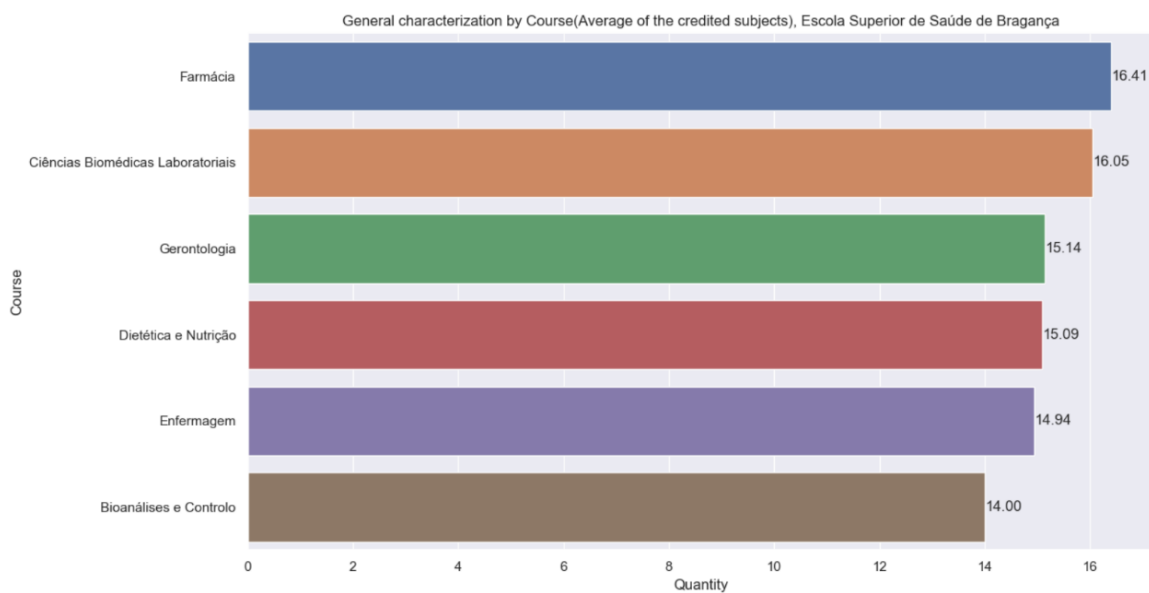

Figure 62: General characterization School and Course (Average of the credited subjects), ESSa

The bar chart below shows the average number of the not credit subjects in different courses. The Y-axis represents courses, and the X-axis represents the average value. The highest average score was in Farmácia at 16.41, and the lowest average score was in Bioanálises e Controlo at 14.00.

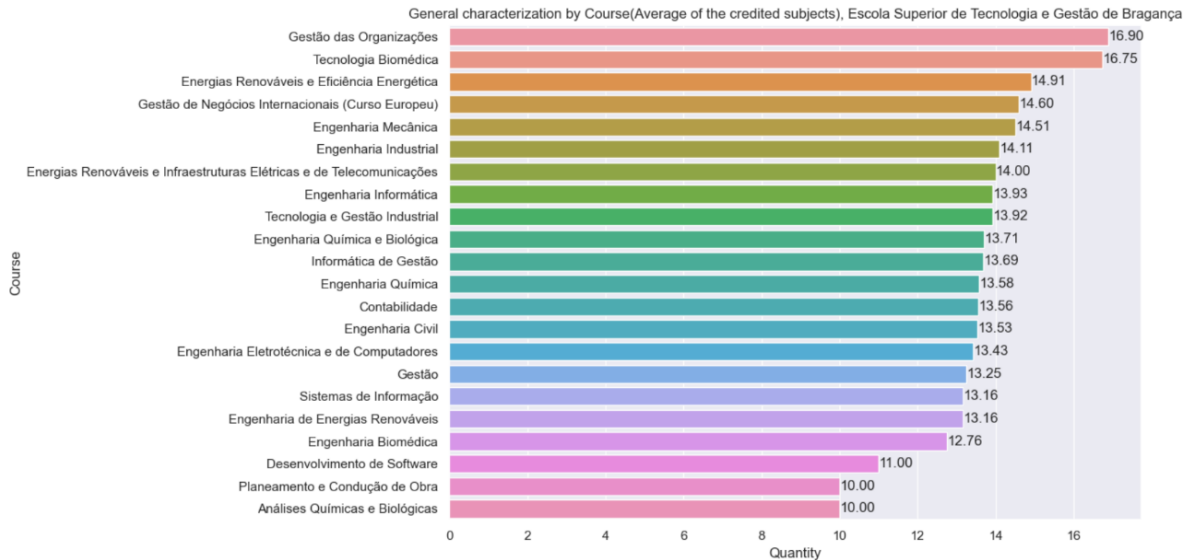

Figure 63: General characterization School and Course (Average of the credited subjects), ESTiG

The bar chart below shows the average number of the not credit subjects in different courses. The Y-axis represents courses, and the X-axis represents the average value. The highest average score was in Gestão das Organizações at 16.90, and the lowest average score was in Análises Químicas e Biológicas at 10.00 and Planeamento e Condução de Obra at 10.00.

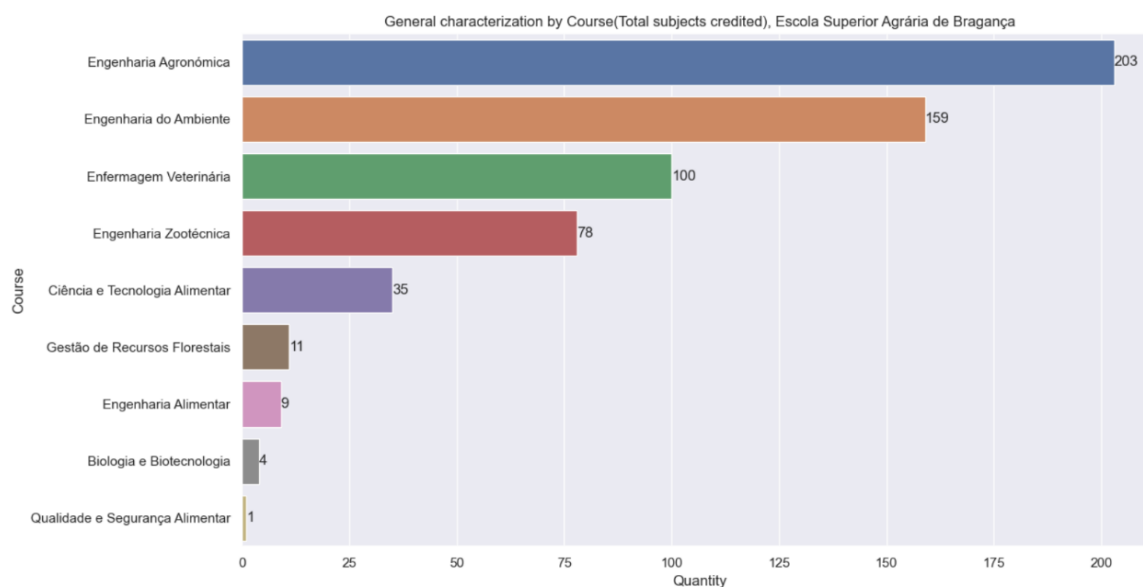

Figure 64: General characterization School and Course (Total subjects credited), ESA

The bar chart below shows the total subjects credited in different courses. The Y-axis represents courses, and the X-axis represents the total value. The highest total score was in Engenharia Agronómica at 203, and the lowest total score was in Qualidade e Segurança Alimentar at 1.

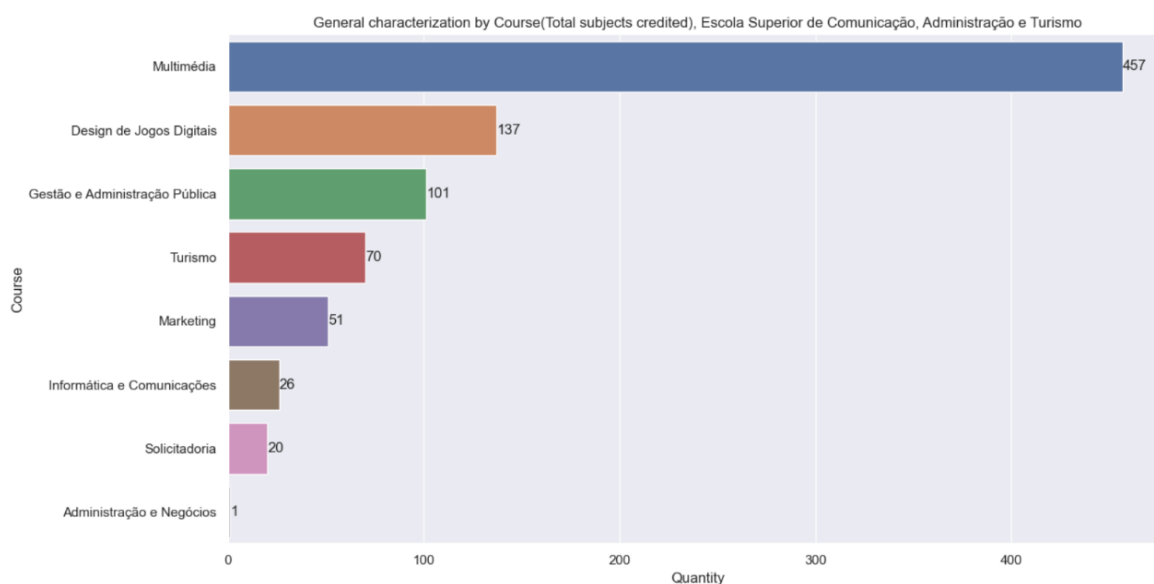

Figure 65: General characterization School and Course (Total subjects credited), EsACT

The bar chart below shows the total subjects credited in different courses. The Y-axis represents courses, and the X-axis represents the total value. The highest total score was in Multimédia at 457, and the lowest total score was in Administração e Negócios at 1.

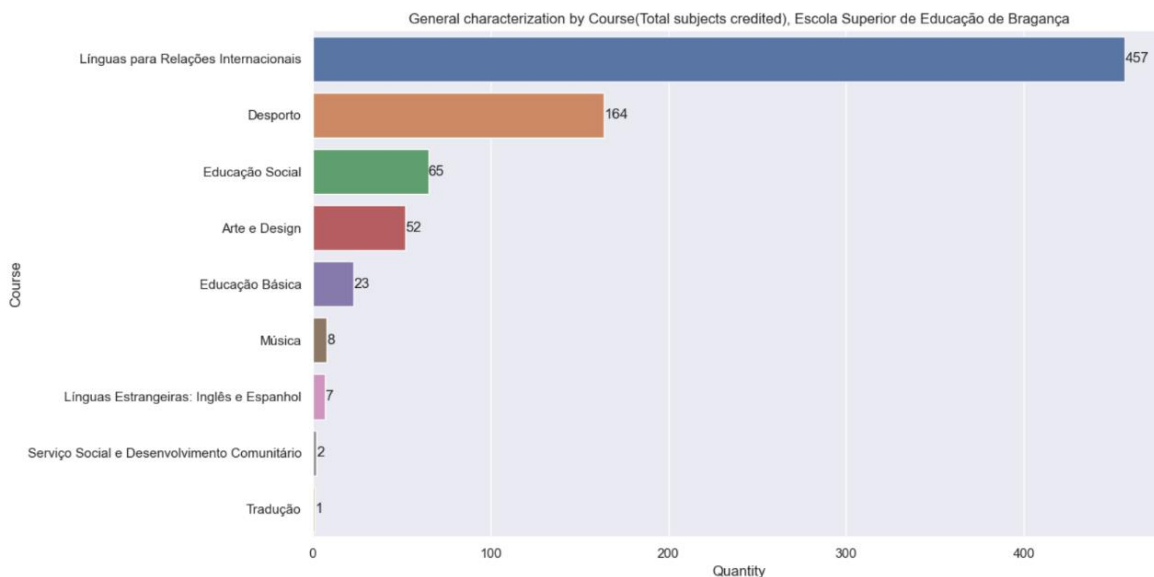

Figure 66: General characterization School and Course (Total subjects credited), ESE

The bar chart below shows the total subjects credited in different courses. The Y-axis represents courses, and the X-axis represents the total value. The highest total score was in Línguas para Relações Internacionais at 457, and the lowest total score was in Tradução at 1.

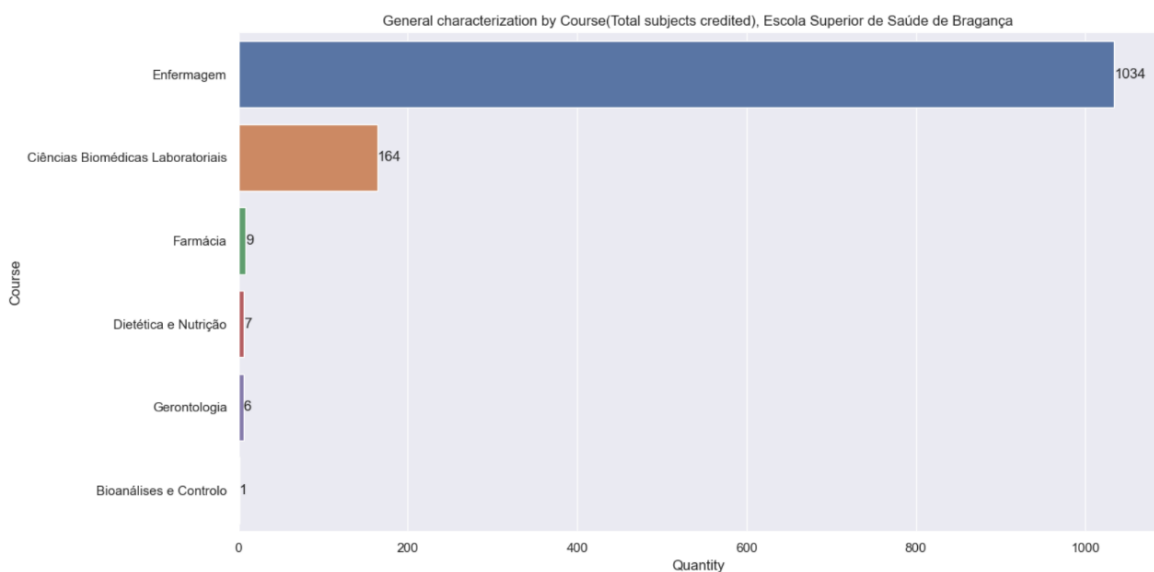

Figure 67: General characterization School and Course (Total subjects credited), ESSa

The bar chart below shows the total subjects credited in different courses. The Y-axis represents courses, and the X-axis represents the total value. The highest total score was in Enfermagem at 1034, and the lowest total score was in Bioanálises e Controlo at 1.

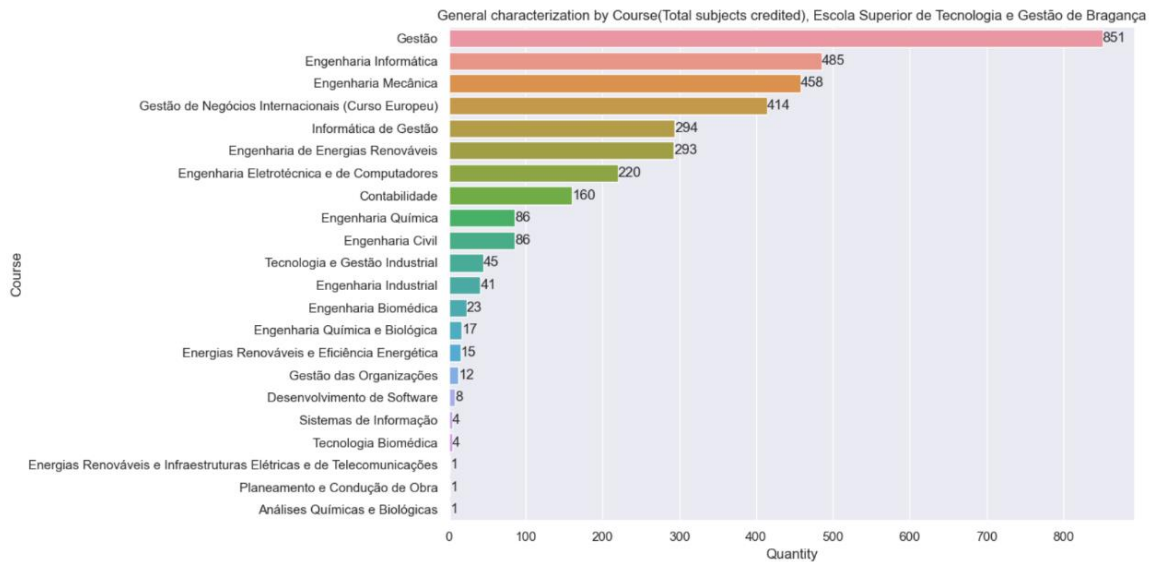

Figure 68: General characterization School and Course (Total subjects credited), ESTiG

The bar chart below shows the total subjects credited in different courses. The Y-axis represents courses, and the X-axis represents the total value. The highest total score was in Gestão at 851, and the lowest total score was in Energias Renováveis e Infraestruturas Elétricas e de Telecomunicações at 1 and Planeamento e Condução de Obra at 1 and Análises Químicas e Biológicas at 1.

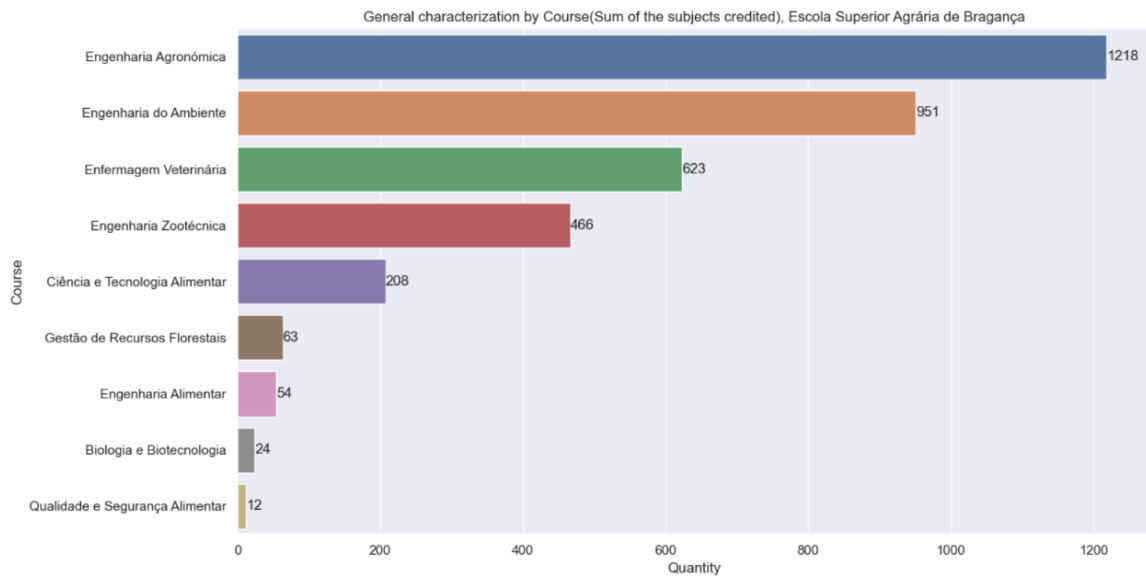

Figure 69: General characterization School and Course (Sum of the subjects credited), ESA

The bar chart below shows the sum of the subjects credited in different courses. The Y-axis represents courses, and the X-axis represents the sum value. The highest sum score was in Engenharia Agronómica at 1218, and the lowest sum score was in Qualidade e Segurança Alimentar at 12.

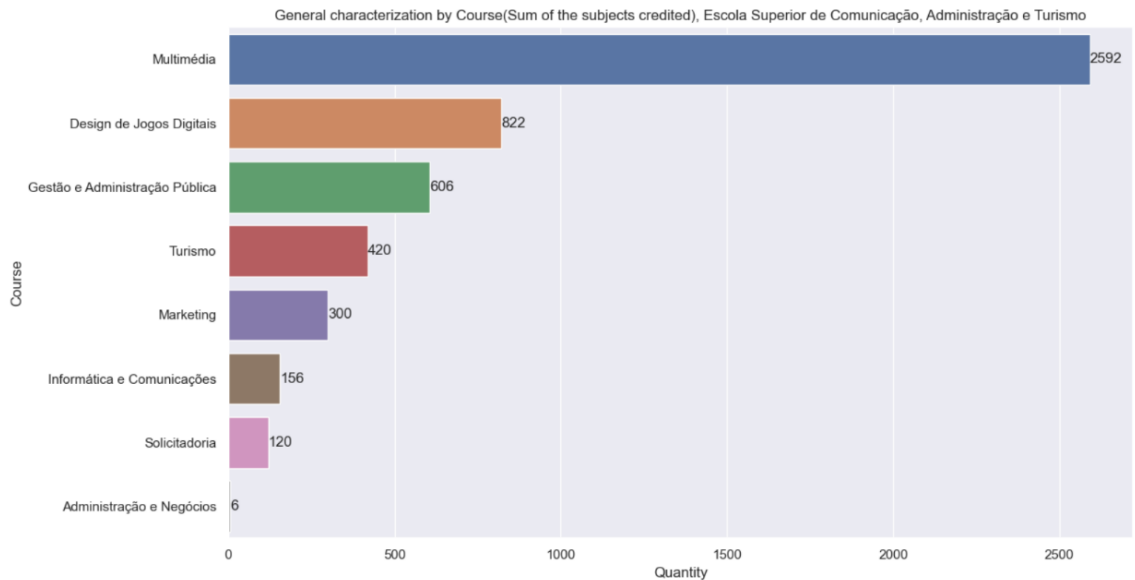

Figure 70: General characterization School and Course (Sum of the subjects credited), EsACT

The bar chart below shows the sum of the subjects credited in different courses. The Y-axis represents courses, and the X-axis represents the sum value. The highest sum score was in Multimédia at 2592, and the lowest sum score was in Administração e Negócios at 6.

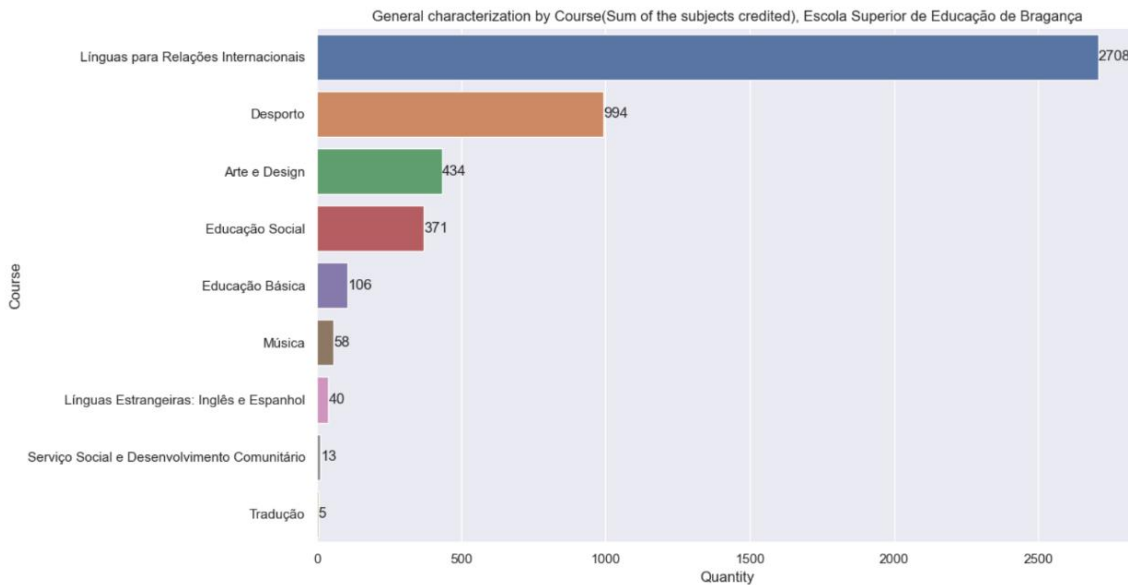

Figure 71: General characterization School and Course (Sum of the subjects credited), ESE

The bar chart below shows the sum of the subjects credited in different courses. The Y-axis represents courses, and the X-axis represents the sum value. The highest sum score was in Línguas para Relações Internacionais at 2708, and the lowest sum score was in Tradução at 5.

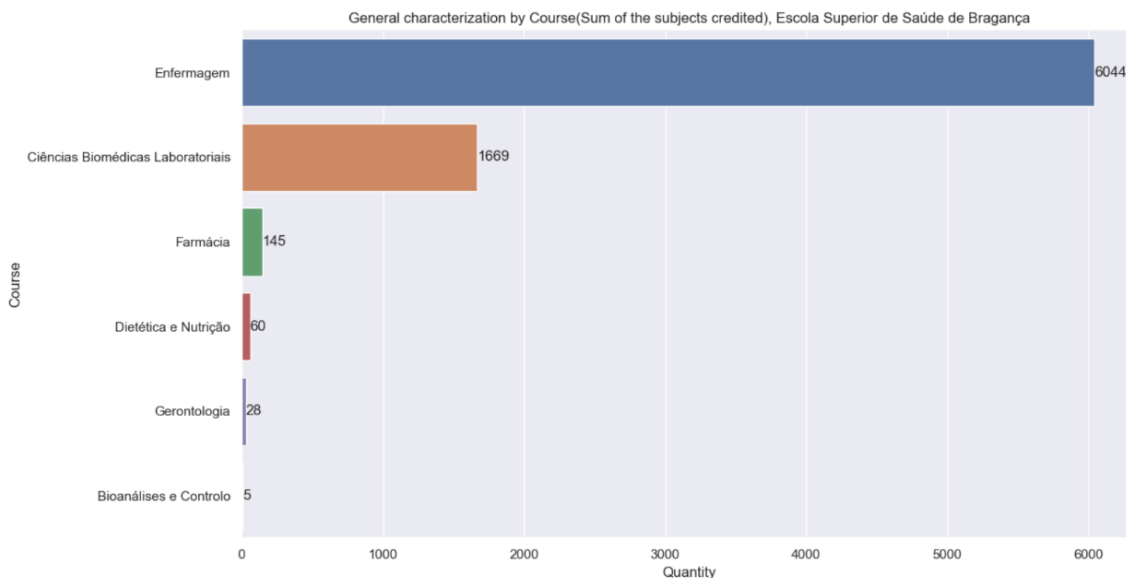

Figure 72: General characterization School and Course (Sum of the subjects credited), ESSa

The bar chart below shows the sum of the subjects credited in different courses. The Y-axis represents courses, and the X-axis represents the sum value. The highest sum score was in Enfermagem at 2708, and the lowest sum score was in Bioanálises e Controlo at 5.

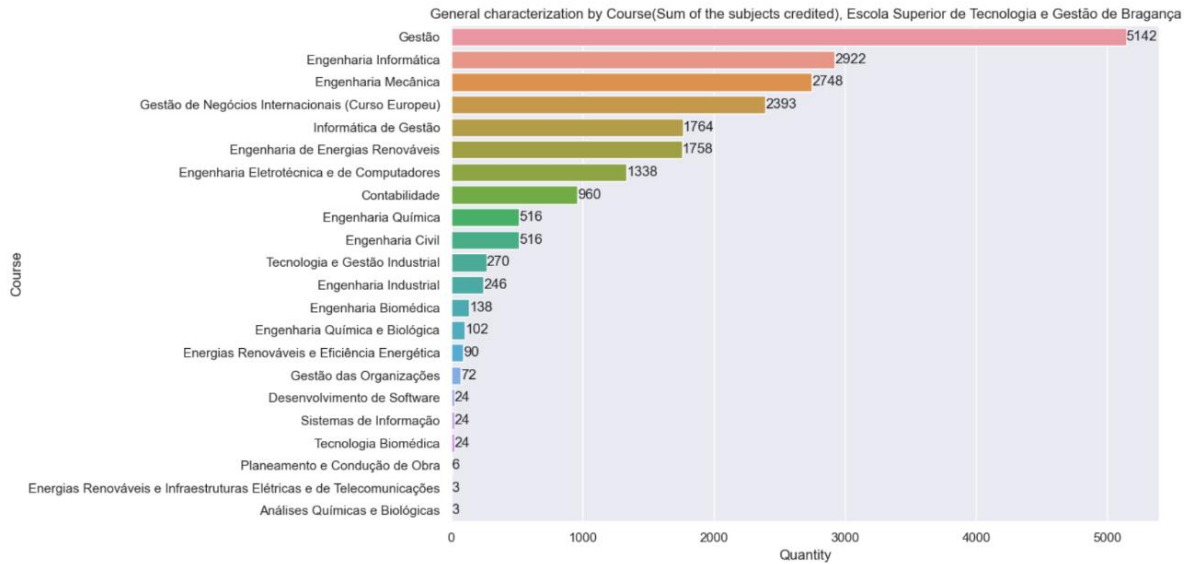

Figure 73: General characterization School and Course (Sum of the subjects credited), ESTiG

The bar chart below shows the sum of the subjects credited in different courses. The Y-axis represents courses, and the X-axis represents the sum value. The highest sum score was in Gestão at 5142, and the lowest sum score was in Energias Renováveis e Infraestruturas Eléctricas e de Telecomunicações at 3 and Análises Químicas e Biológicas at 3.

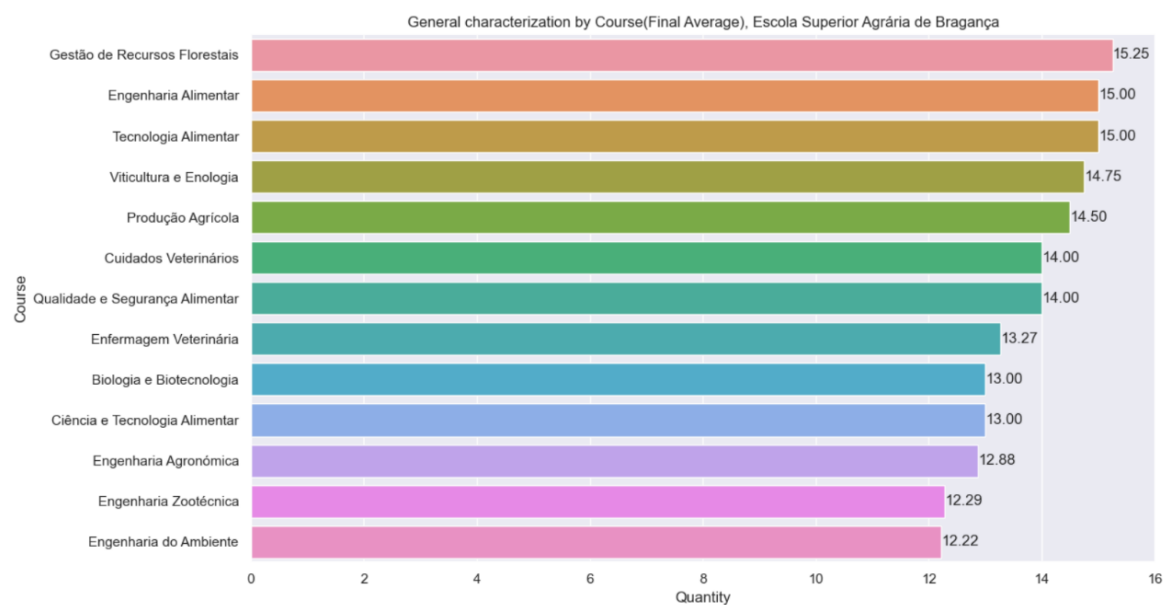

Figure 74: General characterization School and Course (Final Average), ESA

The bar chart below shows the final average in different courses. The Y-axis represents courses, and the X-axis represents the average value. The highest average score was in Gestão de Recursos Florestais at 15.25, and the lowest average score was in Engenharia do Ambiente at 12.22.

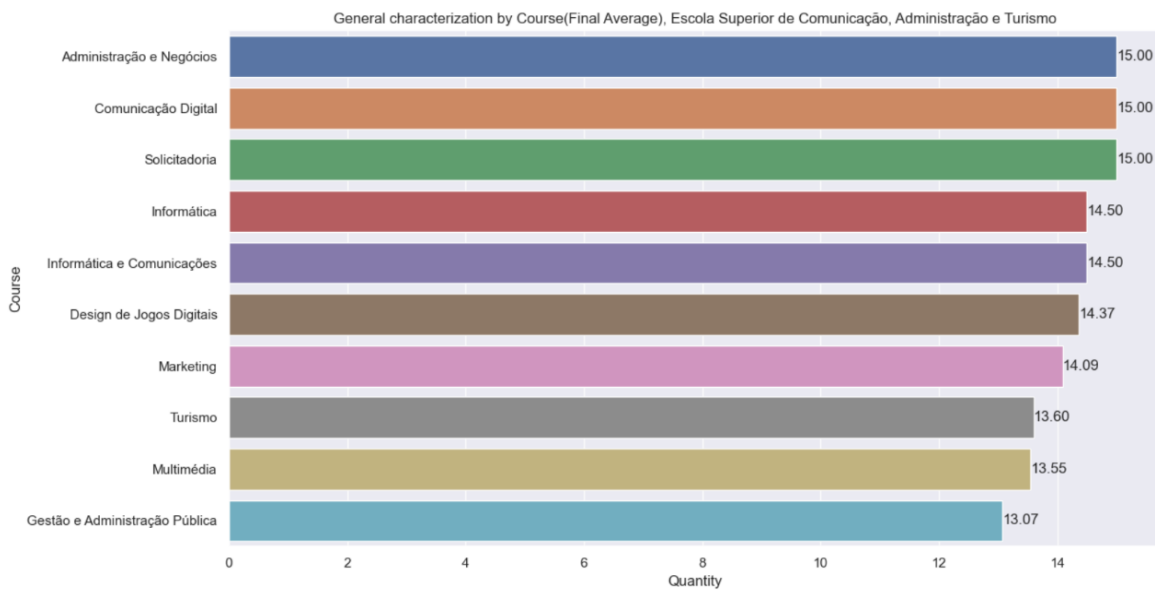

Figure 75: General characterization School and Course (Final Average), EsACT

The bar chart below shows the final average in different courses. The Y-axis represents courses, and the X-axis represents the average value. The highest average score was in Administração e Negócios at 15.00 and Comunicação Digital at 15.00 and Solicitadoria at 15.00; the lowest average score was in Gestão e Administração Pública at 13.07.

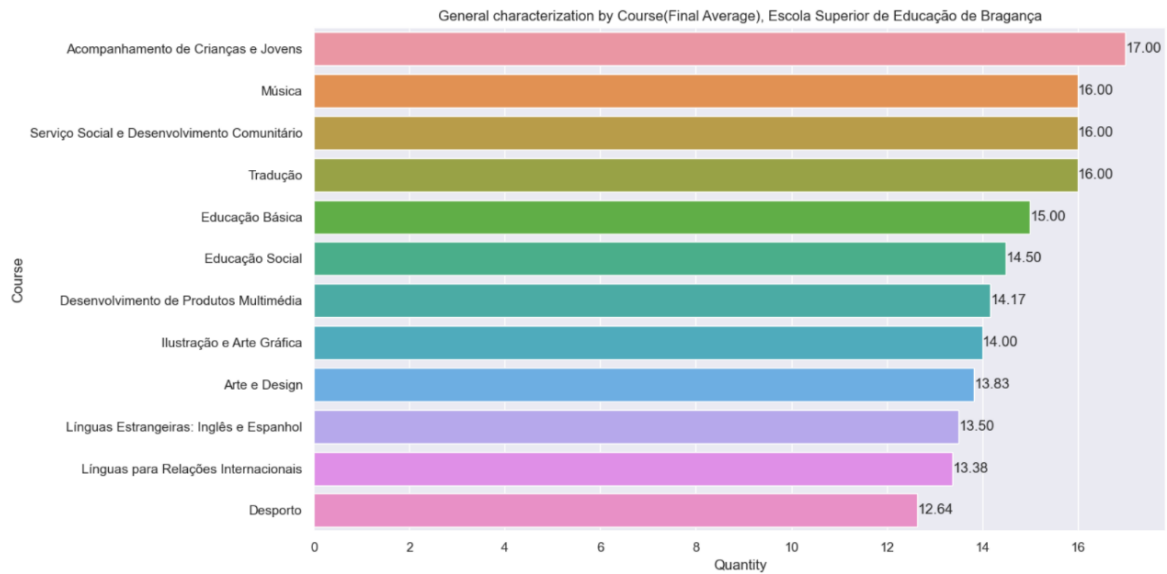

Figure 76: General characterization School and Course (Final Average), ESE

The bar chart below shows the final average in different courses. The Y-axis represents courses, and the X-axis represents the average value. The highest average score was in Acompanhamento de Crianças e Jovens at 17.00, and the lowest average score was in Desporto at 12.64.

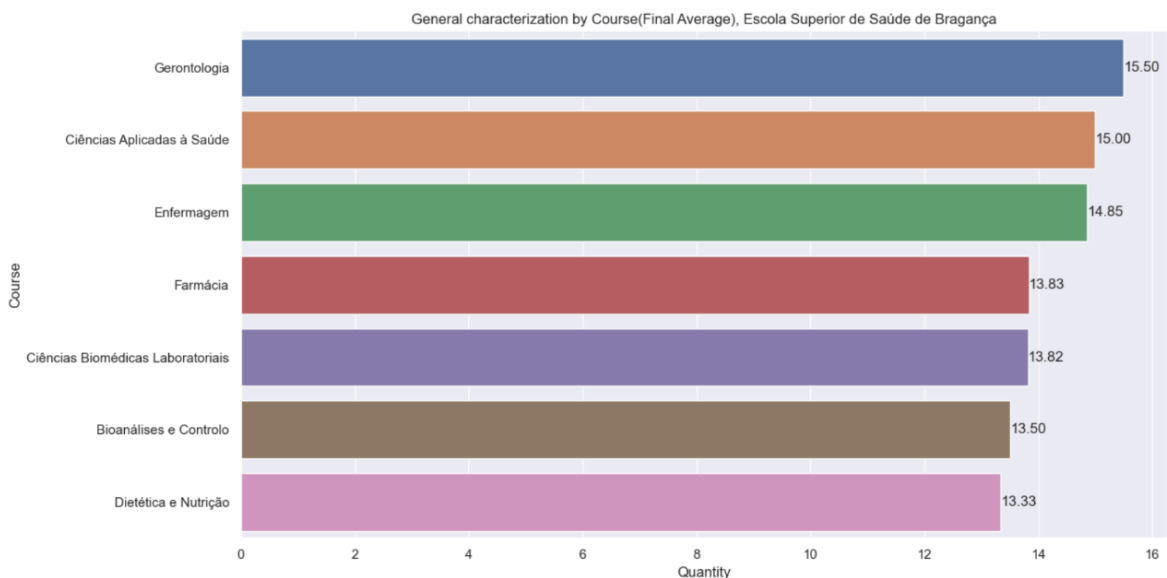

Figure 77: General characterization School and Course (Final Average), ESSa

The bar chart below shows the final average in different courses. The Y-axis represents courses, and the X-axis represents the average value. The highest average score was in Gerontologia at 15.50, and the lowest average score was in Dietética e Nutrição at 13.33.

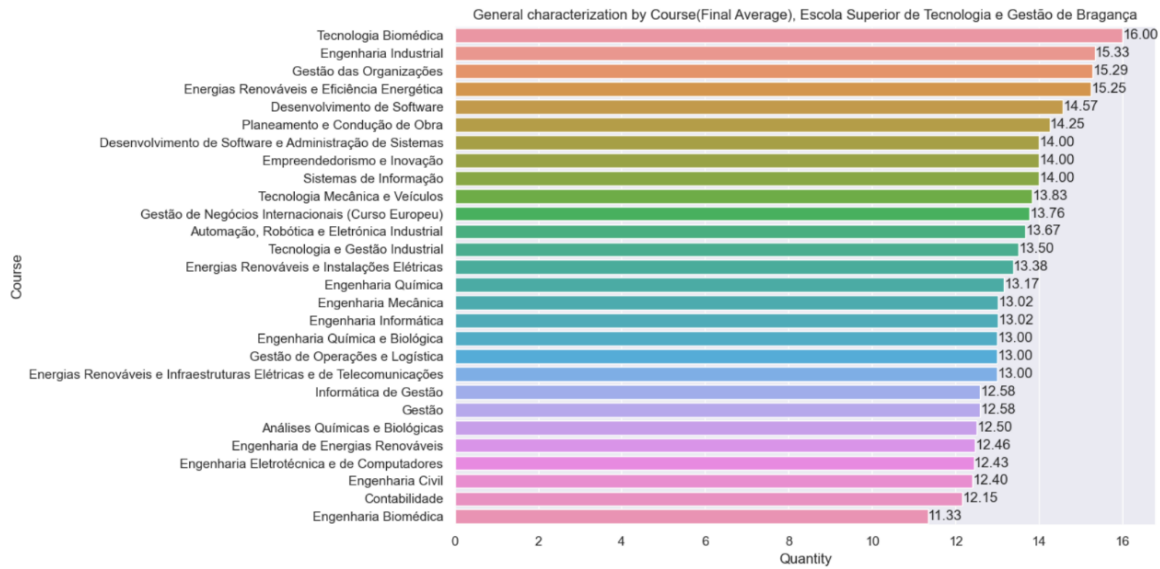

Figure 78: General characterization School and Course (Final Average), ESTiG

The bar chart below shows the final average in different courses. The Y-axis represents courses, and the X-axis represents the average value. The highest average score was in Tecnologia Biomédica at 16.00, and the lowest average score was in Engenharia Biomédica at 11.33.

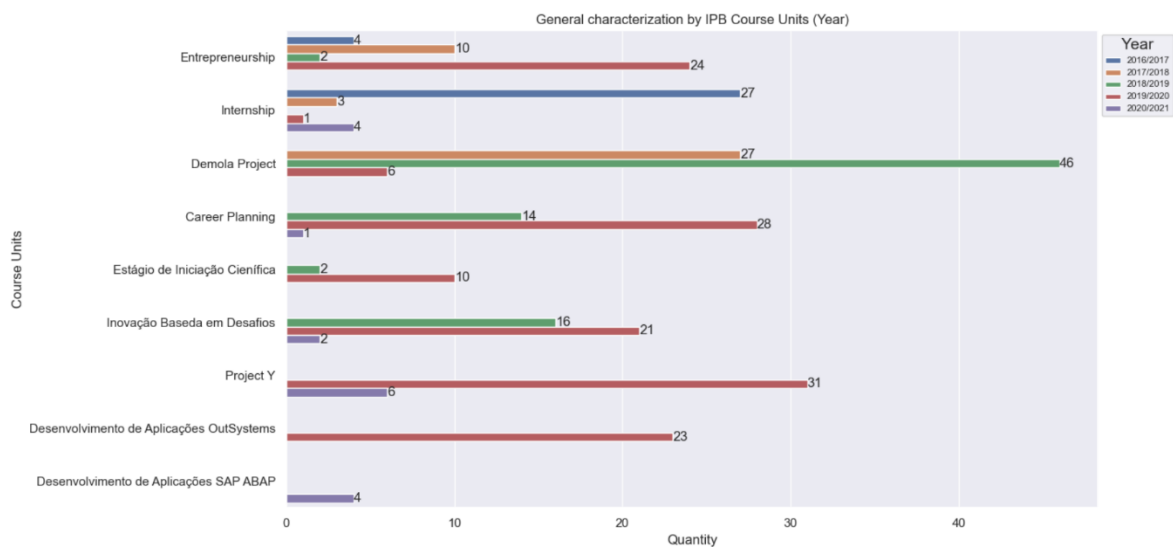

Figure 79: General characterization by IPB Course Units (Year)

The bar chart below shows the count of students in IPB course units. The Y-axis represents IPB Course Units, and the X-axis represents the count of students.

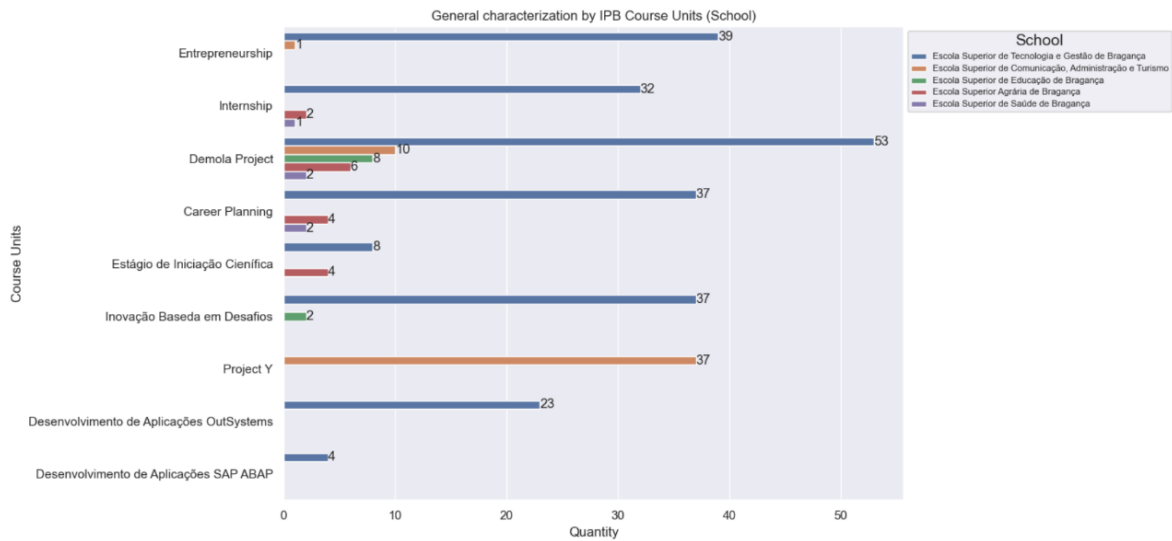

Figure 80: General characterization by IPB Course Units (School)

The bar chart below shows the count of students in IPB course units. The Y-axis represents IPB Course Units, and the X-axis represents the count of students.

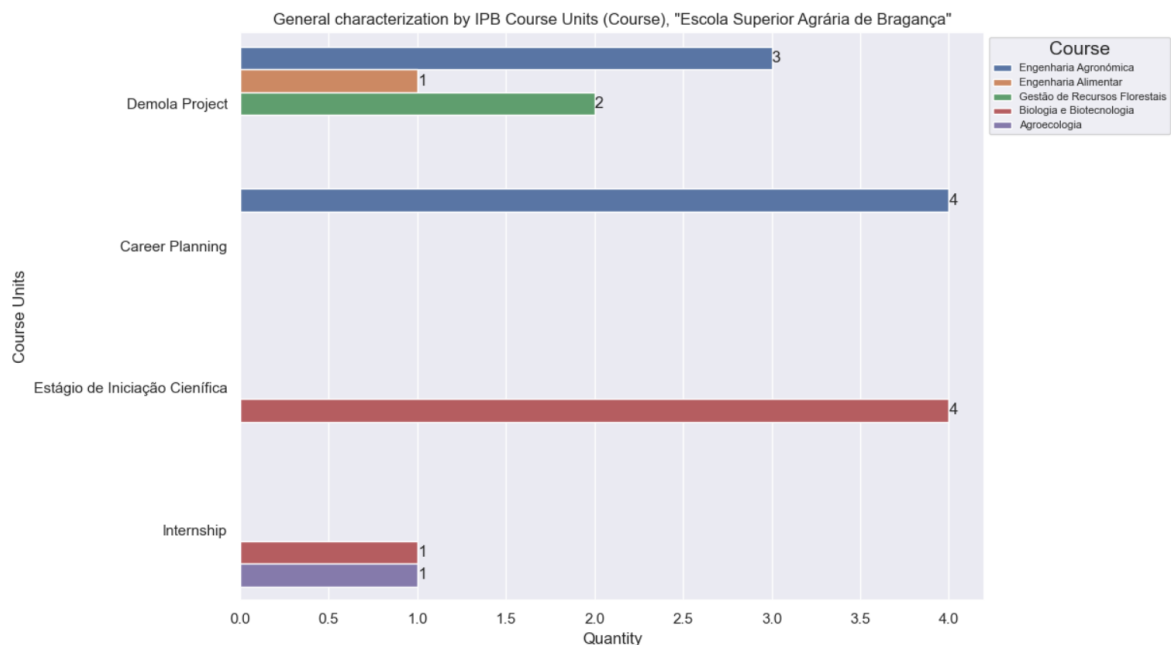

Figure 81: General characterization by IPB Course Units (Course), ESA

The bar chart below shows the count of students in IPB course units. The Y-axis represents IPB Course Units, and the X-axis represents the count of students.

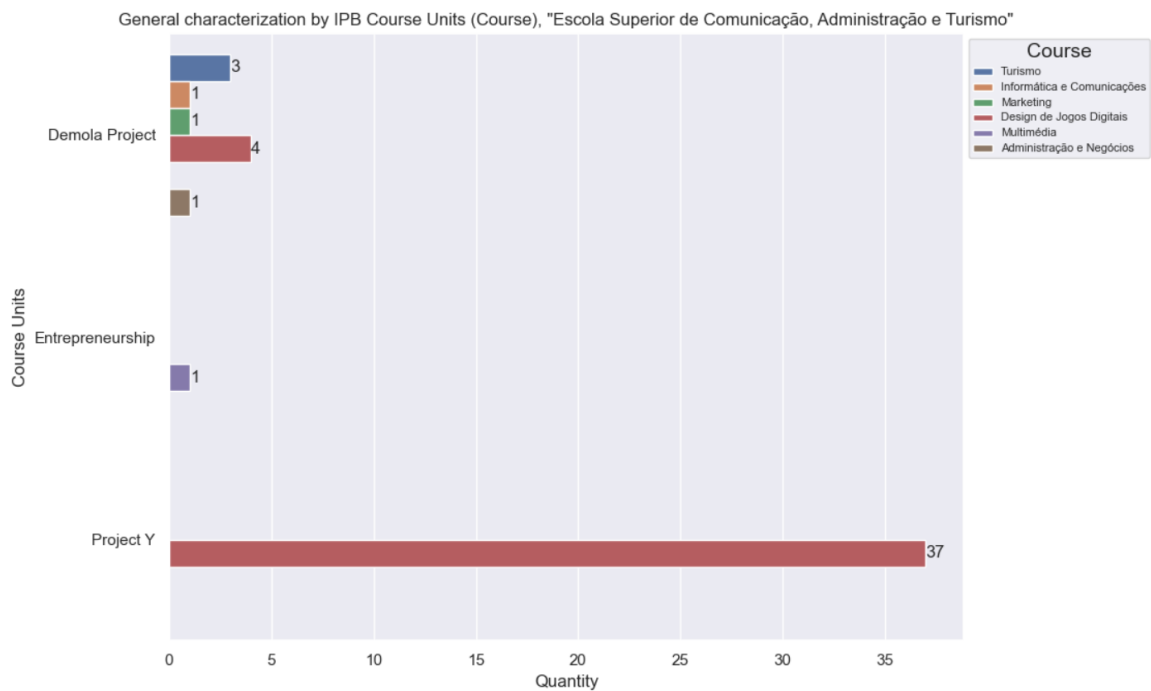

Figure 82: General characterization by IPB Course Units (Course), EsACT

The bar chart below shows the count of students in IPB course units. The Y-axis represents IPB Course Units, and the X-axis represents the count of students.

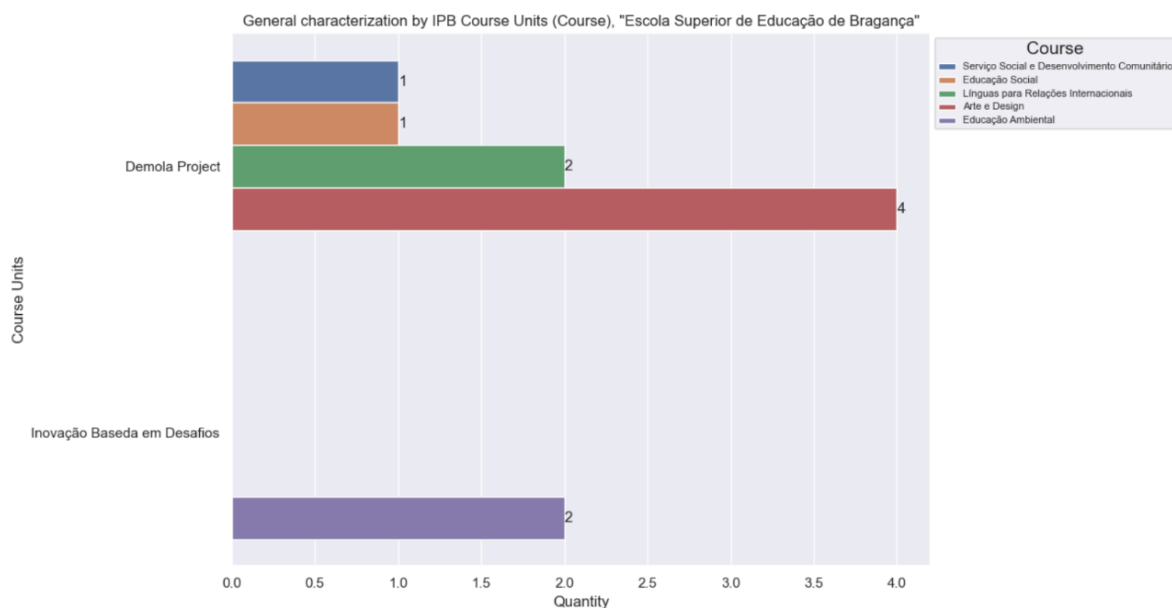

Figure 83: General characterization by IPB Course Units (Course), ESE

The bar chart below shows the count of students in IPB course units. The Y-axis represents IPB Course Units, and the X-axis represents the count of students.

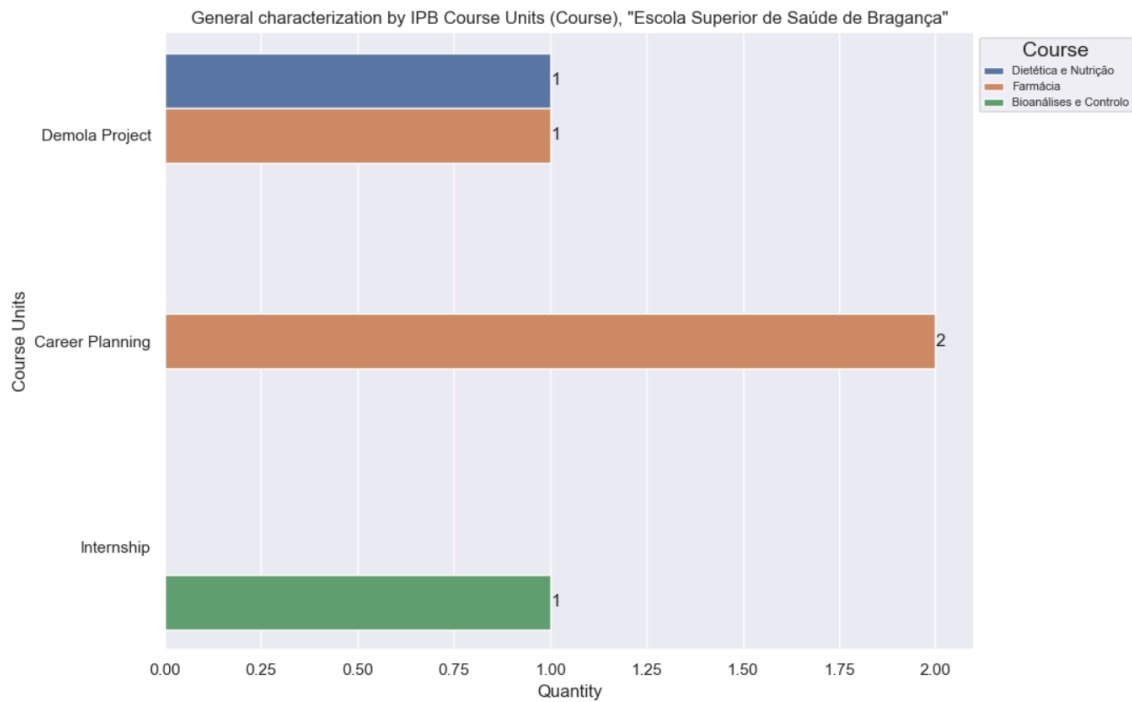

Figure 84: General characterization by IPB Course Units (Course), ESSa

The bar chart below shows the count of students in IPB course units. The Y-axis represents IPB Course Units, and the X-axis represents the count of students.

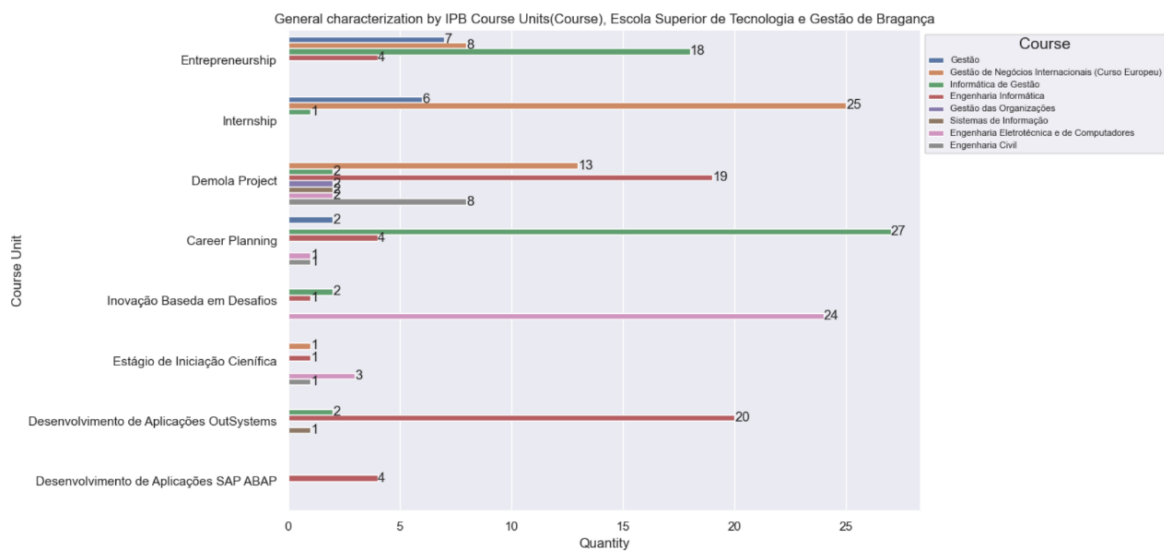

Figure 85: General characterization by IPB Course Units (Course), ESTiG (1st part)

The bar chart below shows the count of students in IPB course units. The Y-axis represents IPB Course Units, and the X-axis represents the count of students.

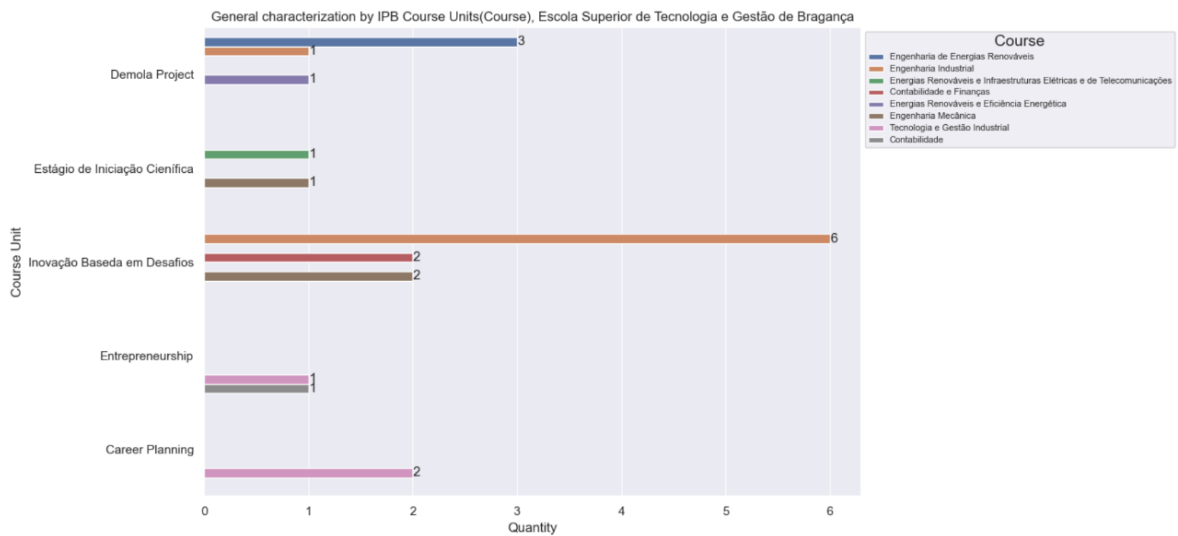

Figure 86: General characterization by IPB Course Units (Course), ESTiG (2ns part)

The bar chart below shows the count of students in IPB course units. The Y-axis represents IPB Course Units, and the X-axis represents the count of students.

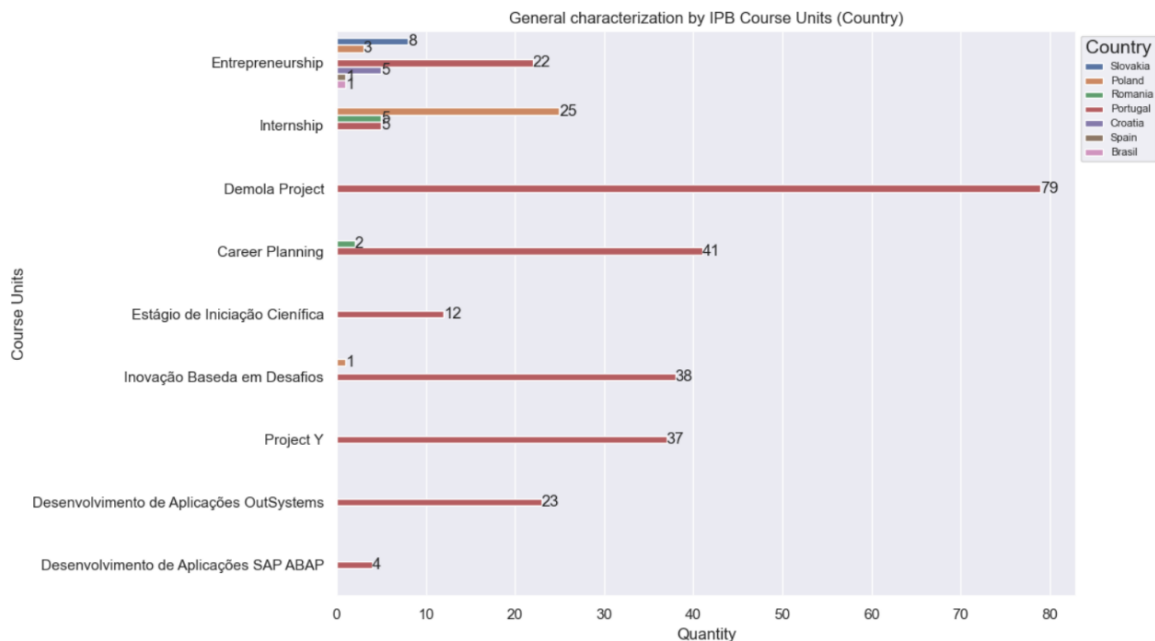

Figure 87: General characterization by IPB Course Units (Country)

The bar chart below shows the count of students in IPB course units. The Y-axis represents IPB Course Units, and the X-axis represents the count of students.

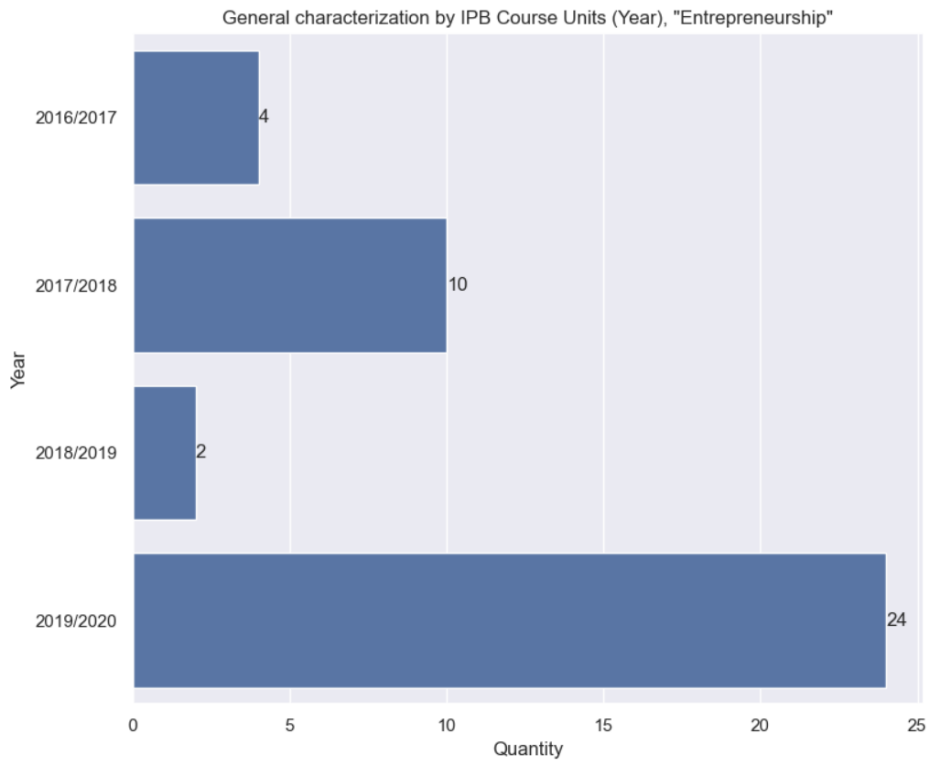

Figure 88: General characterization by IPB Course Units (Year), “Entrepreneurship”

The bar chart below shows the count of students in IPB course units. The Y-axis represents years, and the X-axis represents the count of students.

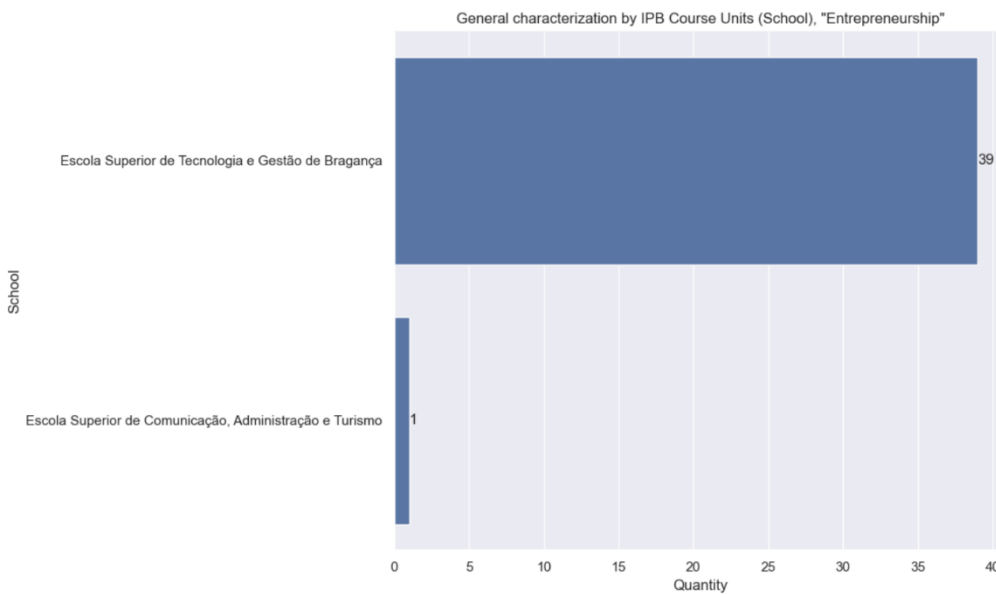

Figure 89: General characterization by IPB Course Units (School), “Entrepreneurship”

The bar chart below shows the count of students in IPB course units. The Y-axis represents schools, and the X-axis represents the count of students.

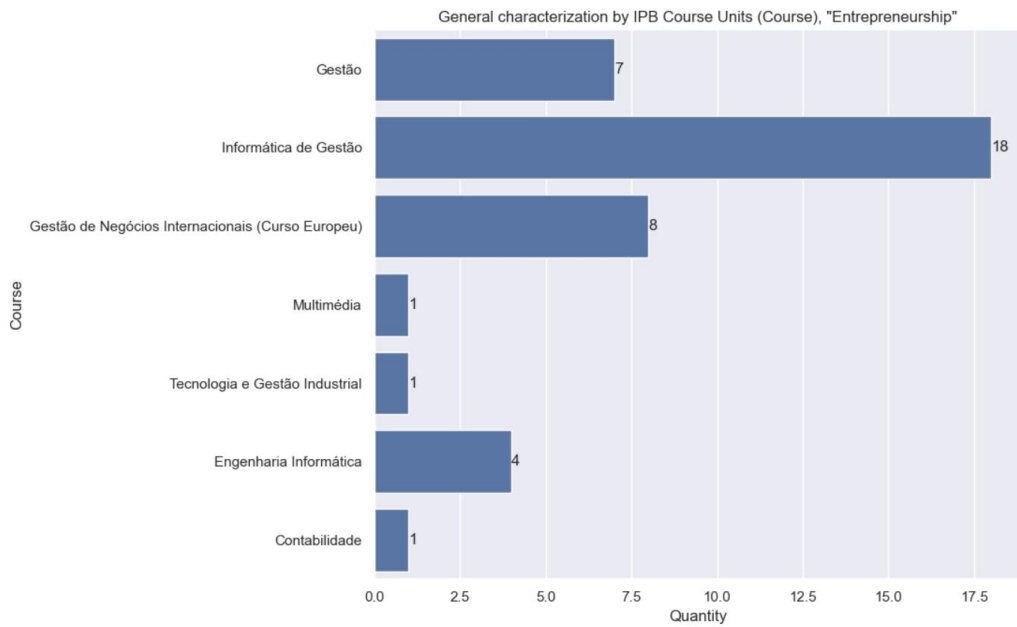

Figure 90: General characterization by IPB Course Units (Course), “Entrepreneurship”

The bar chart below shows the count of students in IPB course units. The Y-axis represents courses, and the X-axis represents the count of students.

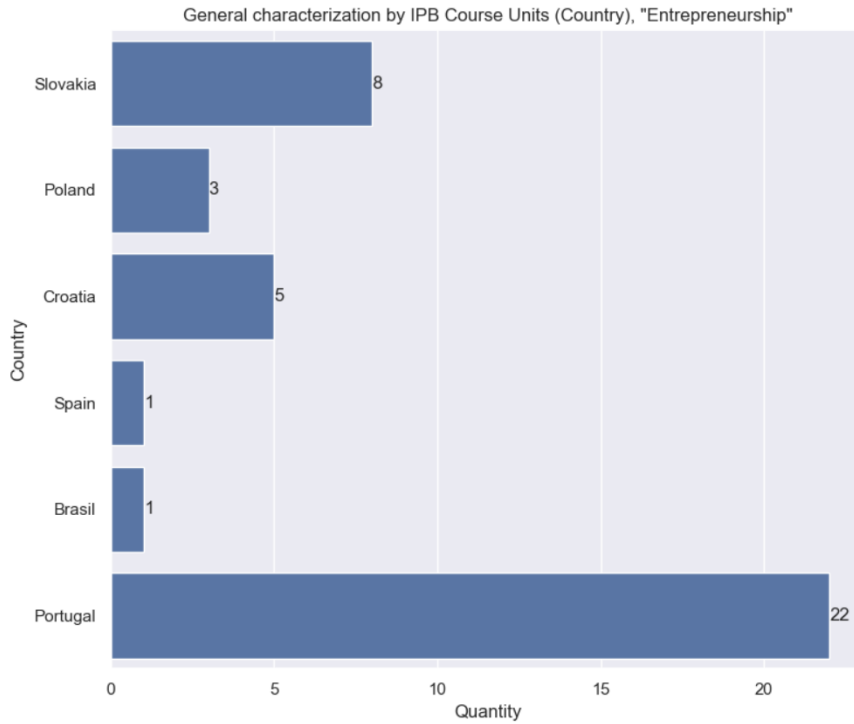

Figure 91: General characterization by IPB Course Units (Country), “Entrepreneurship”

The bar chart below shows the count of students in IPB course units. The Y-axis represents countries, and the X-axis represents the count of students.

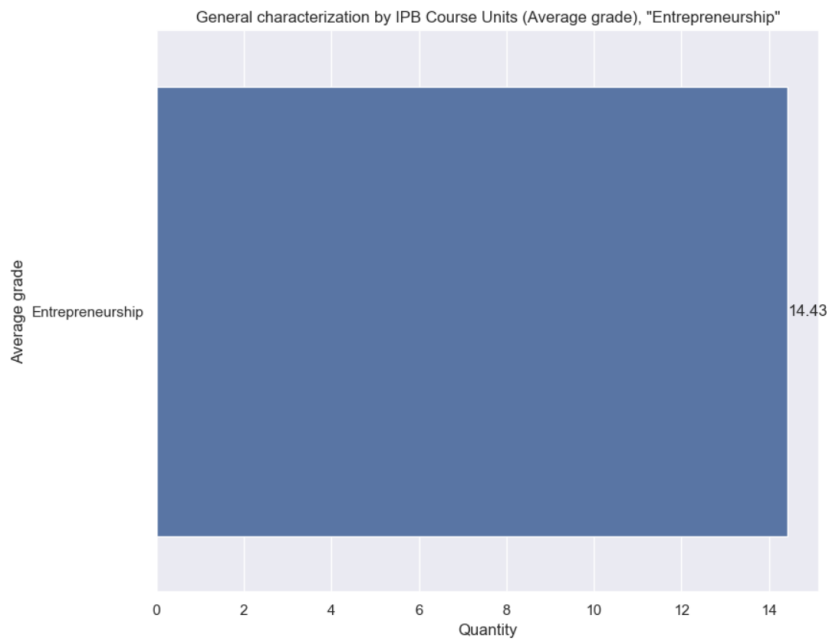

Figure 92: General characterization by IPB Course Units (Average grade), “Entrepreneurship”

The bar chart below shows the average grade in IPB course units. The Y-axis represents course unit, and the X-axis represents the average grade.

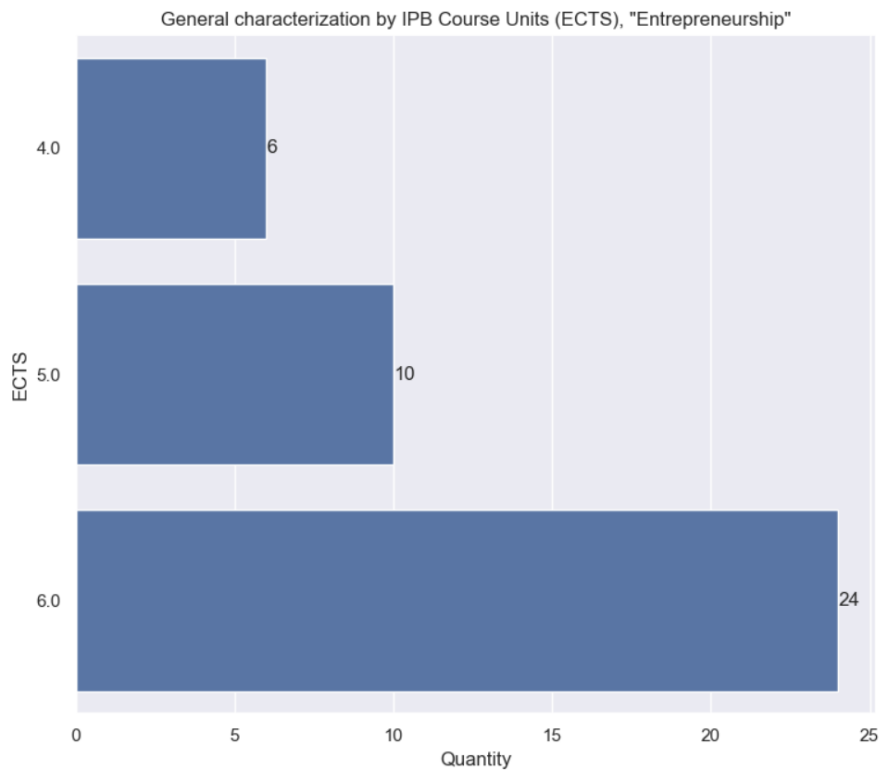

Figure 93: General characterization by IPB Course Units (ECTS), “Entrepreneurship”

The bar chart below shows the count of students in IPB course units. The Y-axis represents ECTS value, and the X-axis represents the count of students.

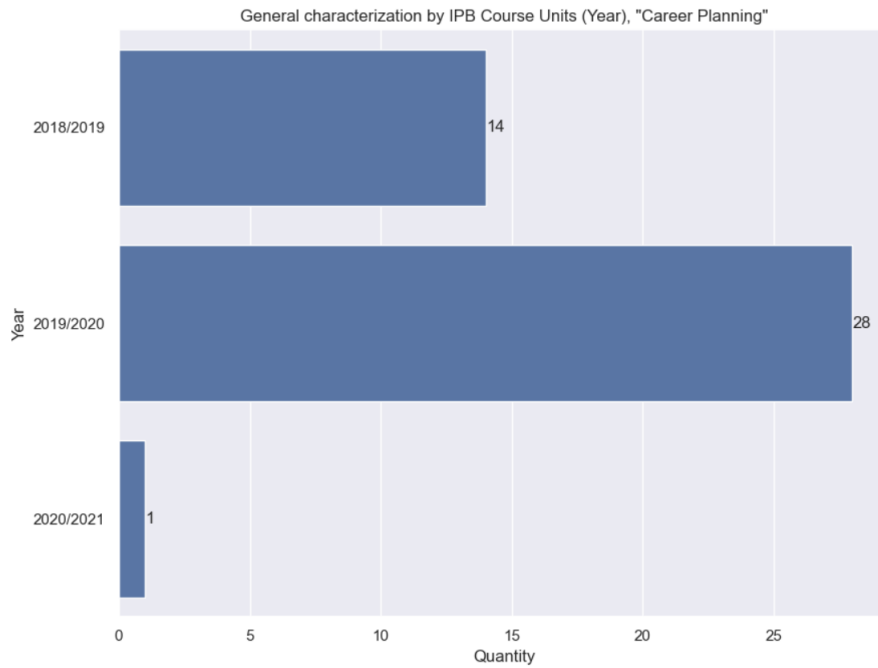

Figure 94: General characterization by IPB Course Units (Year), “Career Planning”

The bar chart below shows the count of students in IPB course units. The Y-axis represents years, and the X-axis represents the count of students.

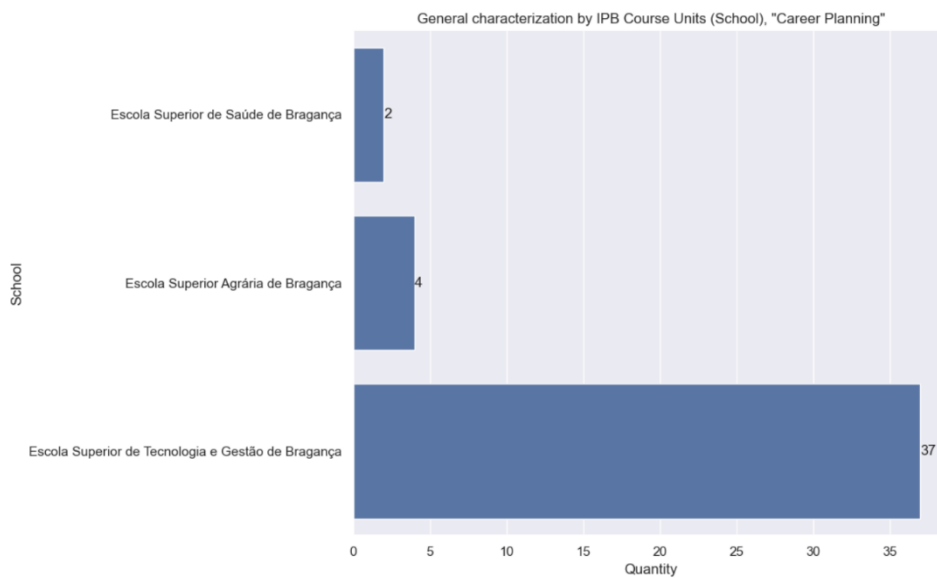

Figure 95: General characterization by IPB Course Units (School), “Career Planning”

The bar chart below shows the count of students in IPB course units. The Y-axis represents schools, and the X-axis represents the count of students.

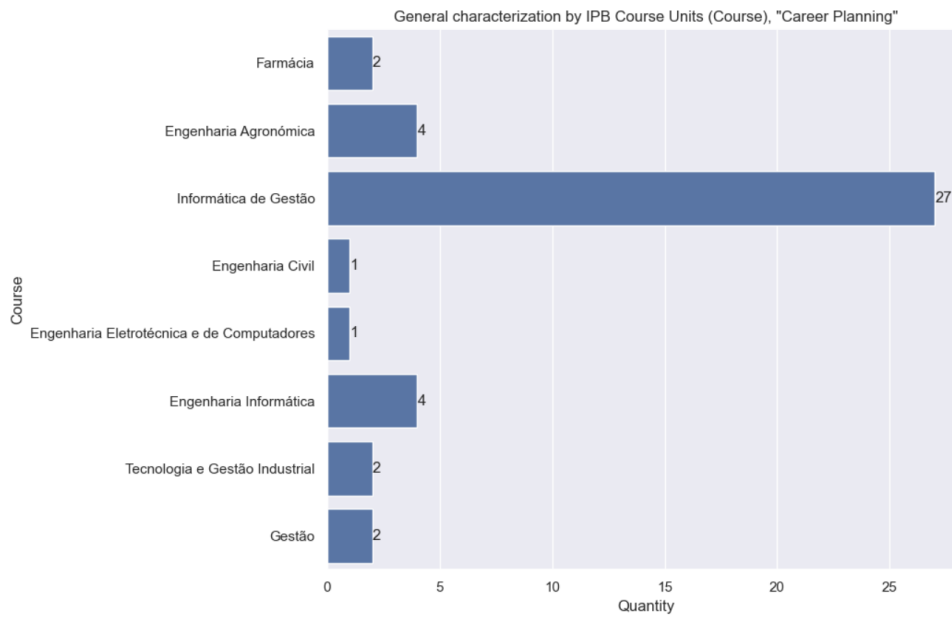

Figure 96: General characterization by IPB Course Units (Course), "Career Planning"

The bar chart below shows the count of students in IPB course units. The Y-axis represents courses, and the X-axis represents the count of students.

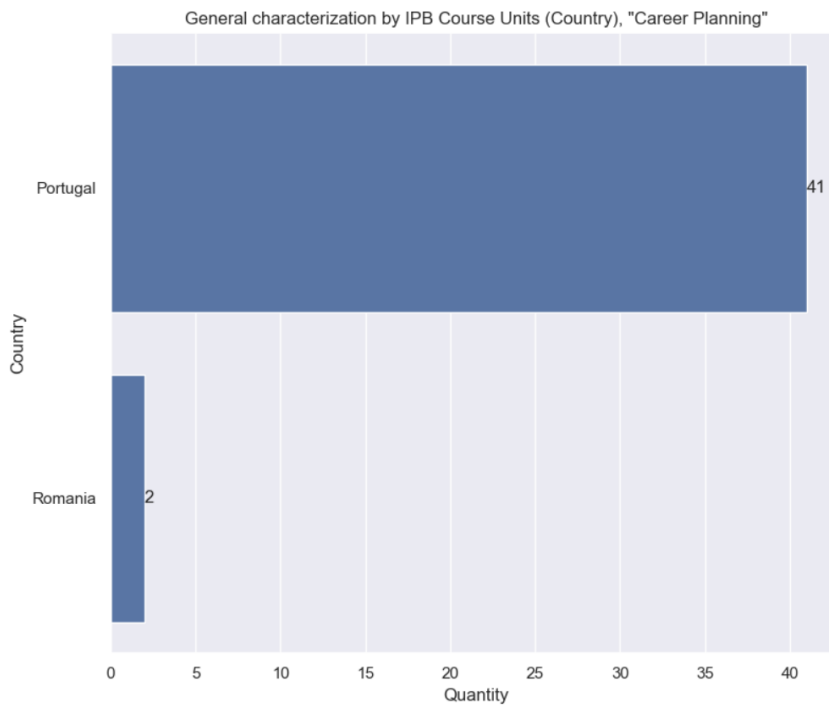

Figure 97: General characterization by IPB Course Units (Country), "Career Planning"

The bar chart below shows the count of students in IPB course units. The Y-axis represents countries, and the X-axis represents the count of students.

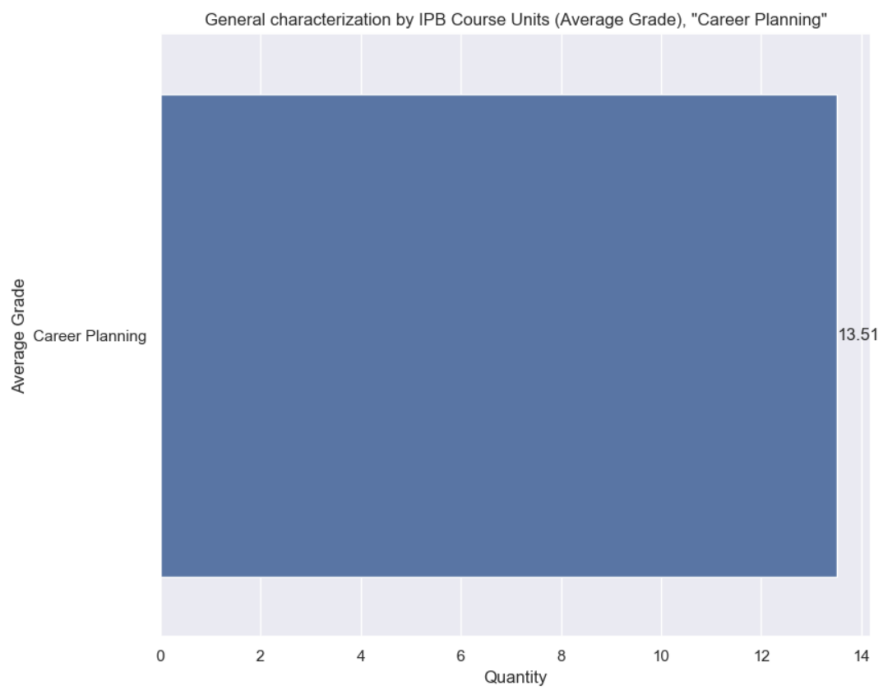

Figure 98: General characterization by IPB Course Units (Average grade), "Career Planning"

The bar chart below shows the average grade in IPB course units. The Y-axis represents course unit, and the X-axis represents the average grade.

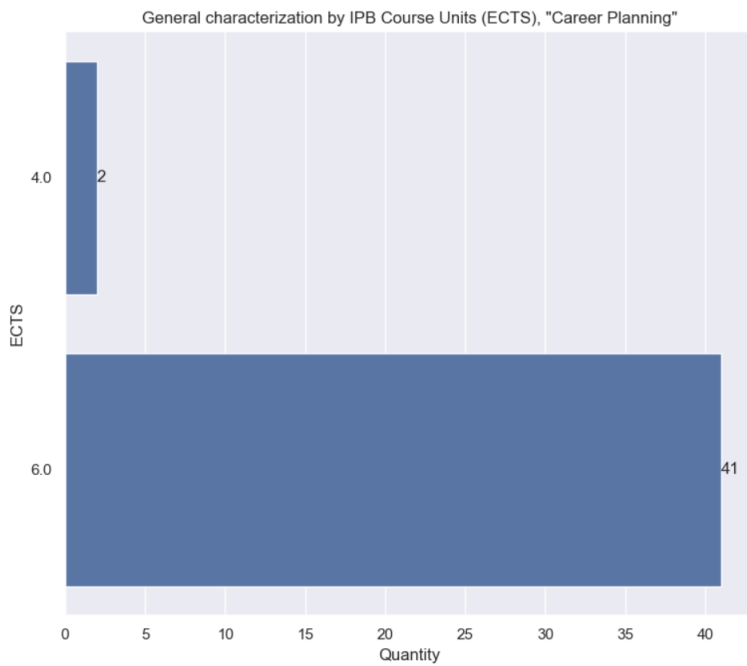

Figure 99: General characterization by IPB Course Units (ECTS), “Career Planning”

The bar chart below shows the ECTS value in IPB course units. The Y-axis represents course unit, and the X-axis represents the ECTS value.

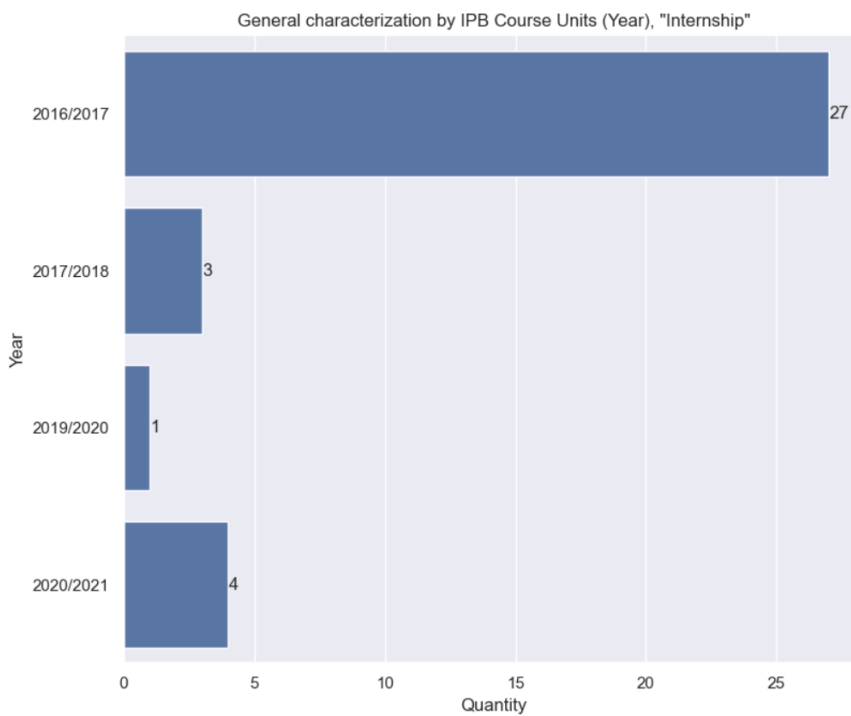

Figure 100: General characterization by IPB Course Units (Year), “Internship”

The bar chart below shows the count of students in IPB course units. The Y-axis represents years, and the X-axis represents the count of students.

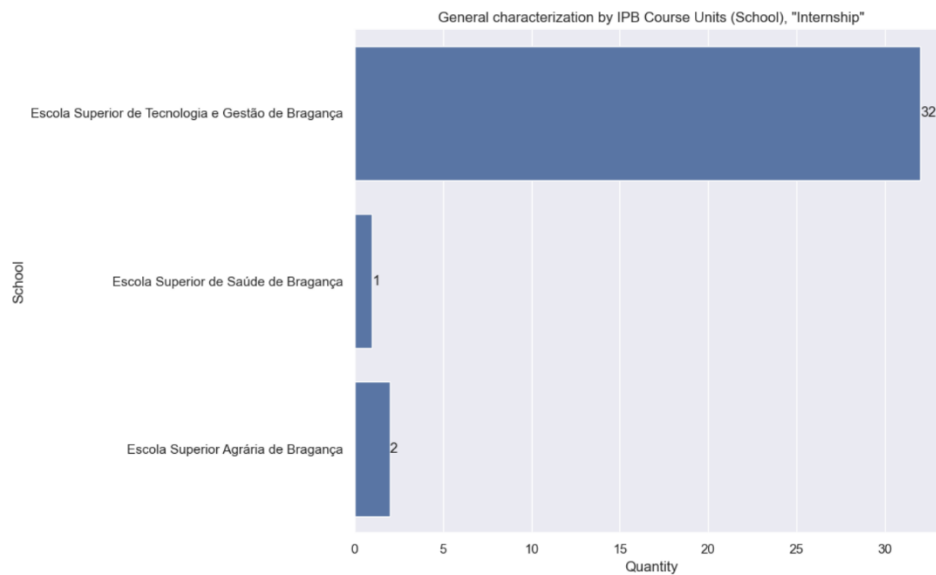

Figure 101: General characterization by IPB Course Units (School), “Internship”

The bar chart below shows the count of students in IPB course units. The Y-axis represents schools, and the X-axis represents the count of students.

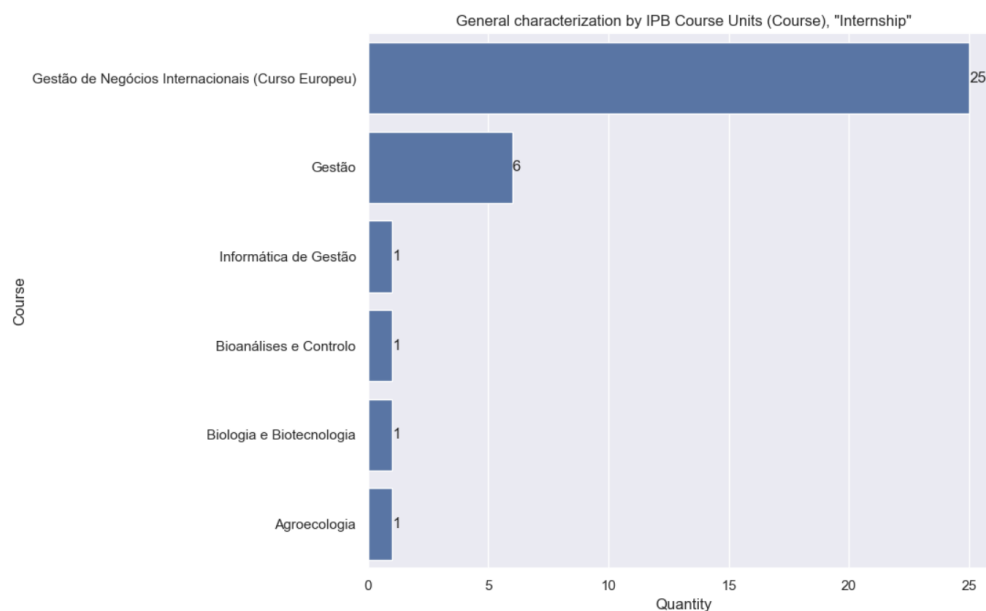

Figure 102: General characterization by IPB Course Units (Course), “Internship”

The bar chart below shows the count of students in IPB course units. The Y-axis represents courses, and the X-axis represents the count of students.

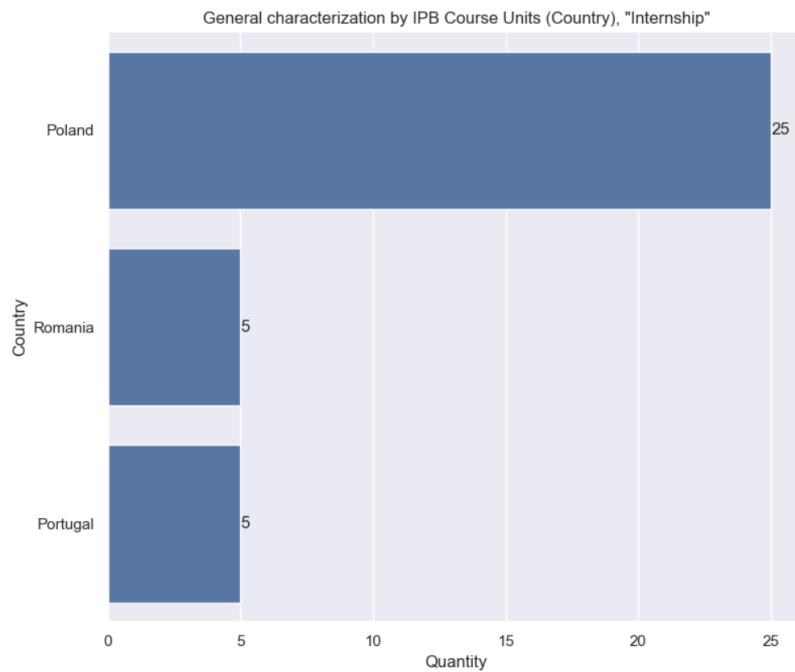

Figure 103: General characterization by IPB Course Units (Country), “Internship”

The bar chart below shows the count of students in IPB course units. The Y-axis represents countries, and the X-axis represents the count of students.

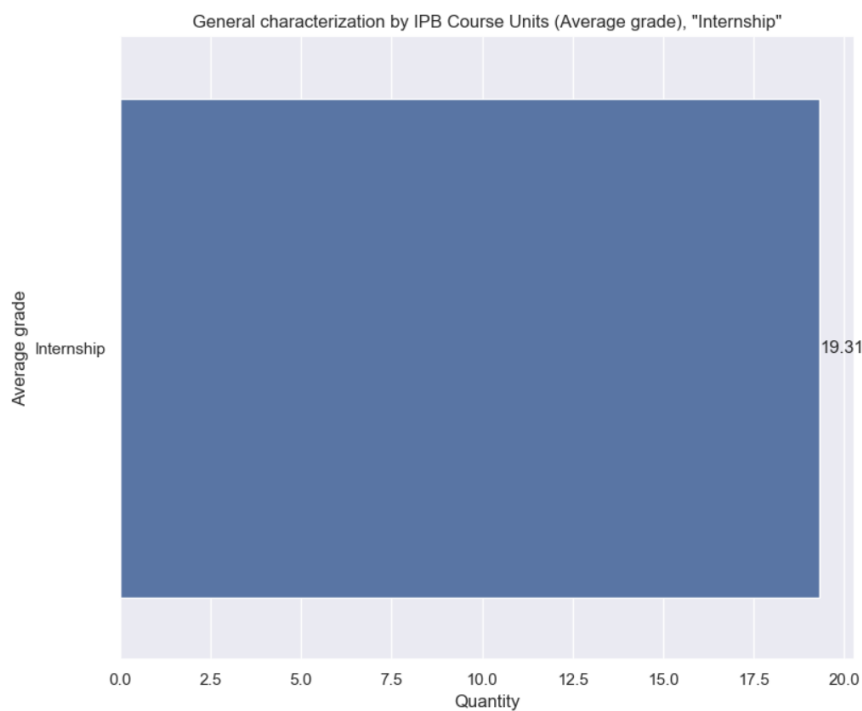

Figure 104: General characterization by IPB Course Units (Average grade), “Internship”

The bar chart below shows the average grade in IPB course units. The Y-axis represents course unit, and the X-axis represents the average value.

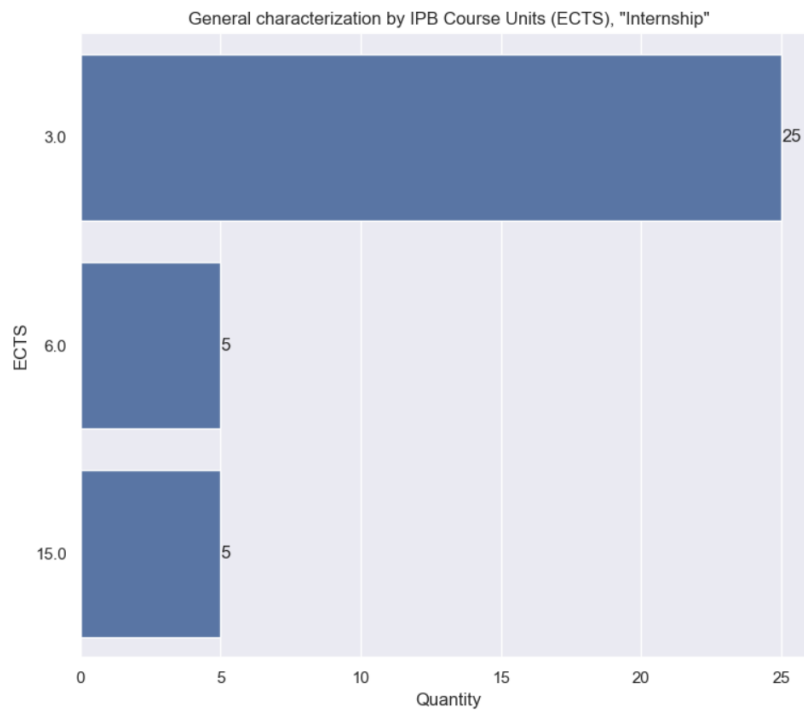

Figure 105: General characterization by IPB Course Units (ECTS), “Internship”

The bar chart below shows the count of students in IPB course units. The Y-axis represents ECTS value, and the X-axis represents the count of students.

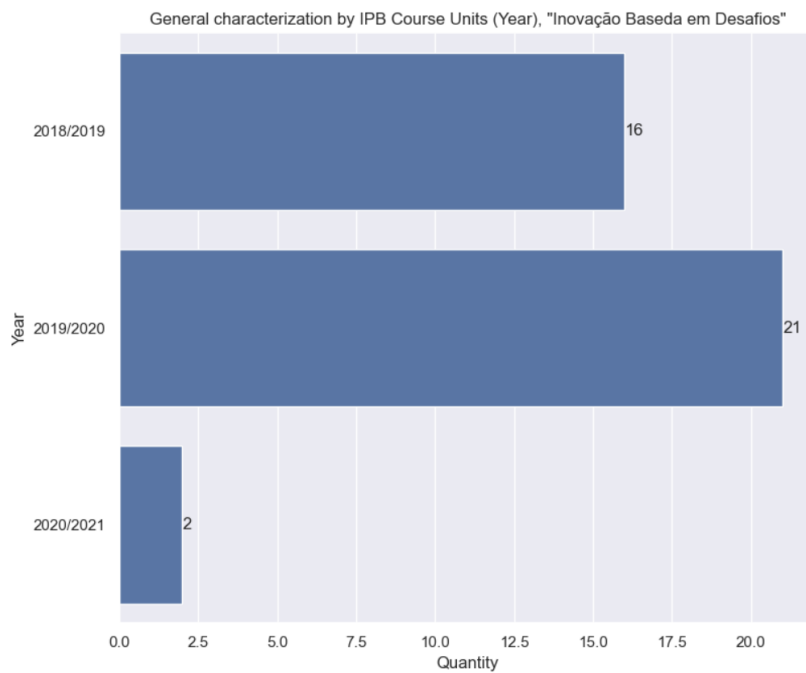

Figure 106: General characterization by IPB Course Units (Year), “Inovacao Baseda em Desafios”

The bar chart below shows the count of students in IPB course units. The Y-axis represents years, and the X-axis represents the count of students.

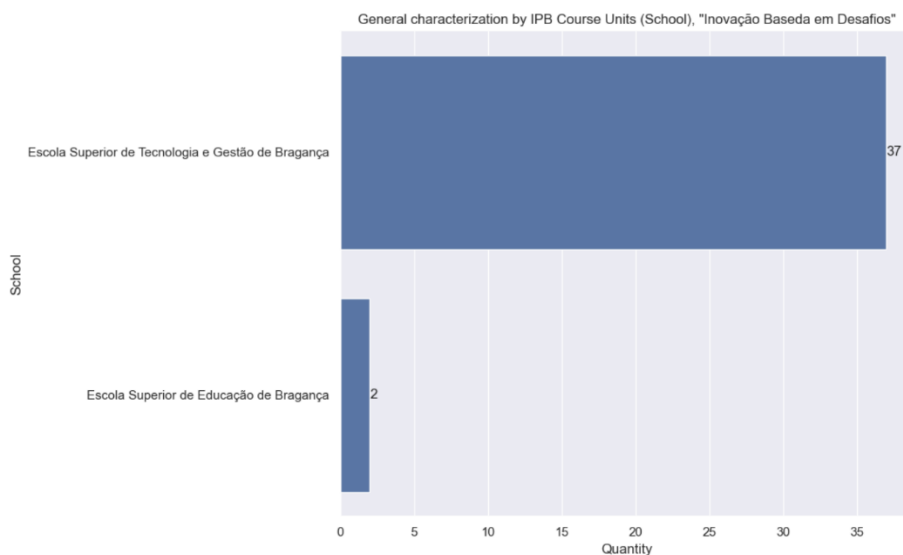

Figure 107: General characterization by IPB Course Units (School), “Inovacao Baseda em Desafios”

The bar chart below shows the count of students in IPB course units. The Y-axis represents schools, and the X-axis represents the count of students.

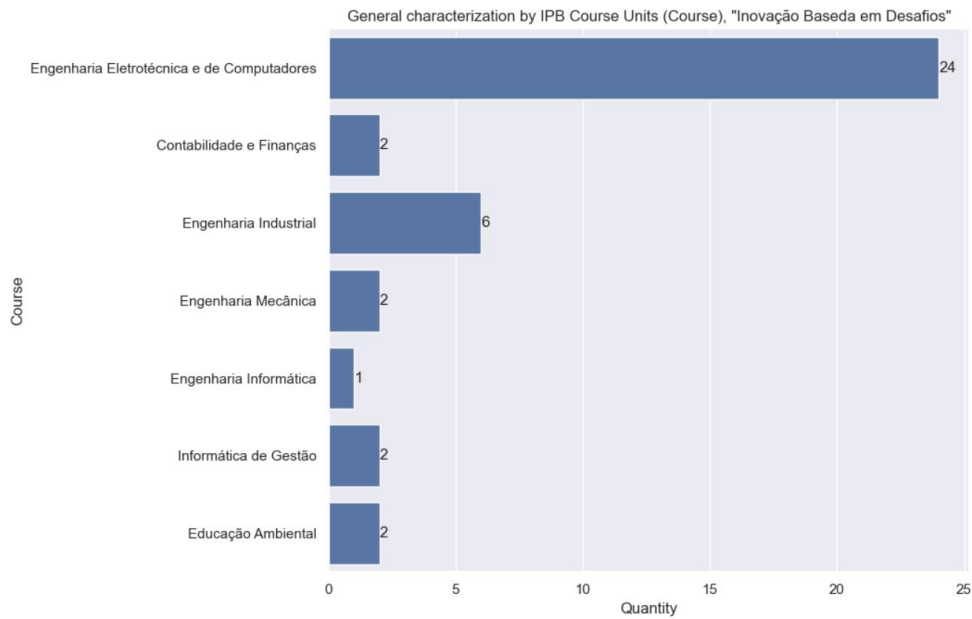

Figure 108: General characterization by IPB Course Units (Courses), “Inovacao Baseda em Desafios”

The bar chart below shows the count of students in IPB course units. The Y-axis represents courses, and the X-axis represents the count of students.

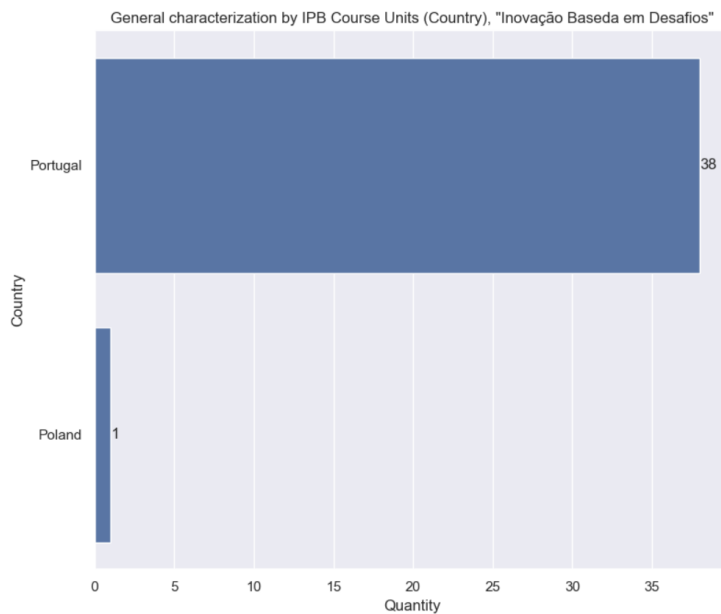

Figure 109: General characterization by IPB Course Units (Country), “Inovacao Baseda em Desafios”

The bar chart below shows the count of students in IPB course units. The Y-axis represents countries, and the X-axis represents the count of students.

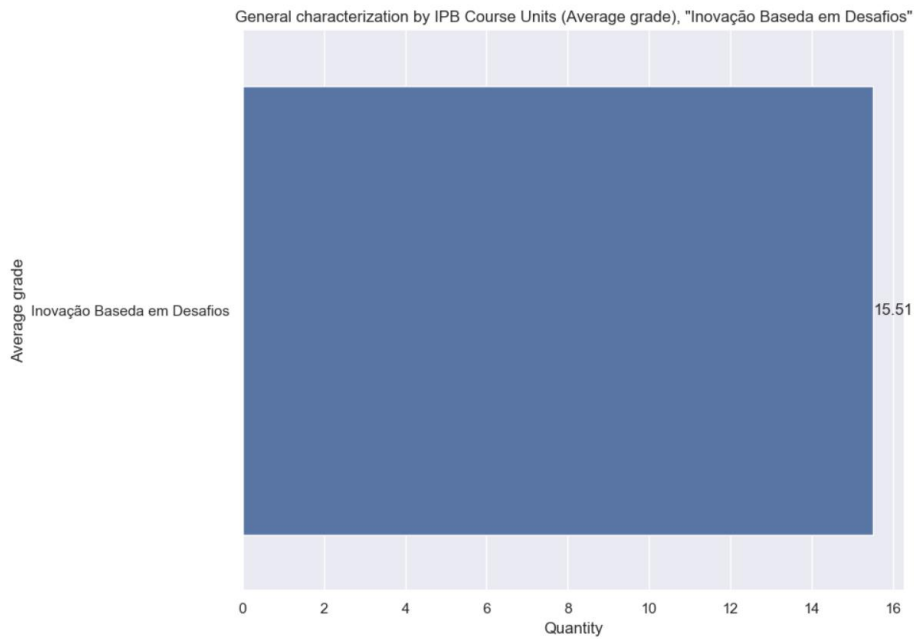

Figure 110: General characterization by IPB Course Units (Average grade), “Inovacao Baseda em Desafios”

The bar chart below shows the average grade in IPB course units. The Y-axis represents course unit, and the X-axis represents the average value.

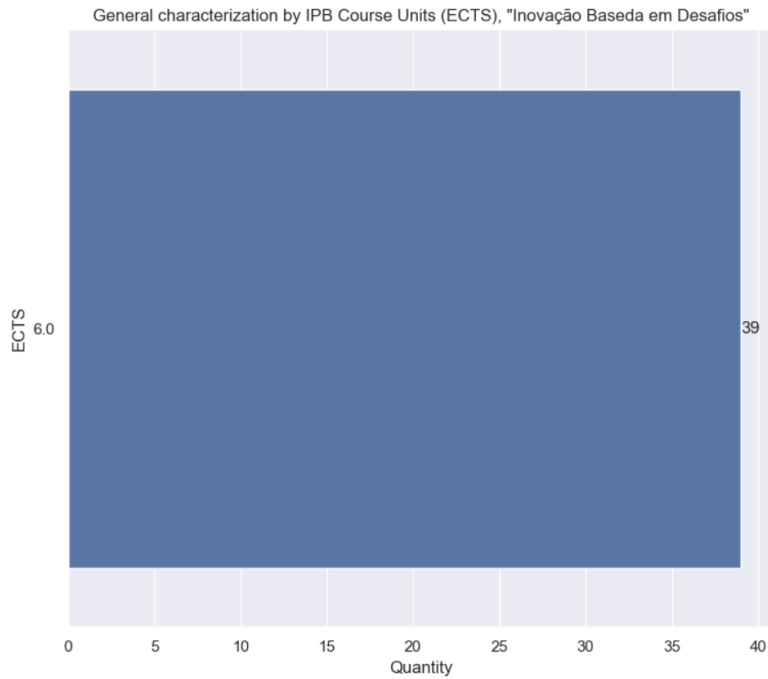

Figure 111: General characterization by IPB Course Units (ECTS), “Inovacao Baseda em Desafios”

The bar chart below shows the count of students in IPB course units. The Y-axis represents ECTS value, and the X-axis represents the count of students.

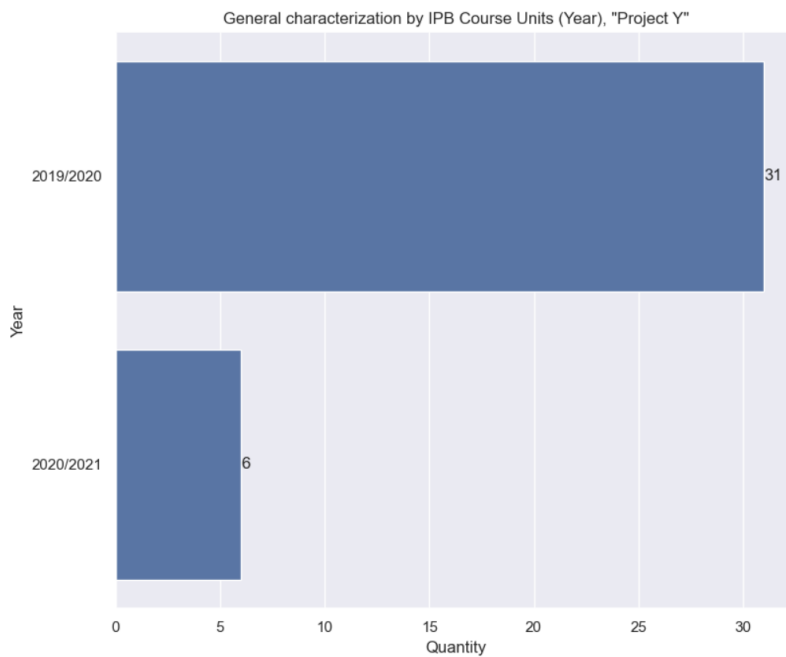

Figure 112: General characterization by IPB Course Units (Year), “Project Y”

The bar chart below shows the count of students in IPB course units. The Y-axis represents years, and the X-axis represents the count of students.

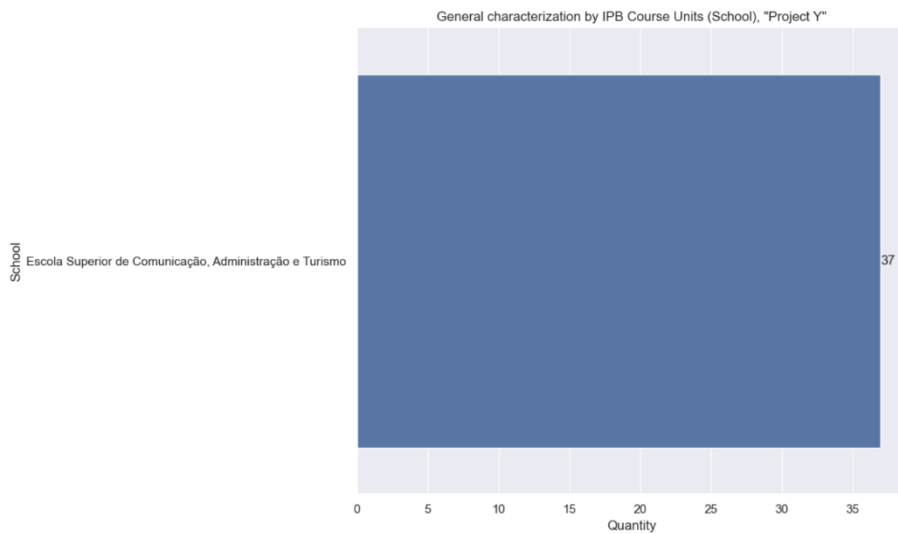

Figure 113: General characterization by IPB Course Units (School), “Project Y”

The bar chart below shows the count of students in IPB course units. The Y-axis represents schools, and the X-axis represents the count of students.

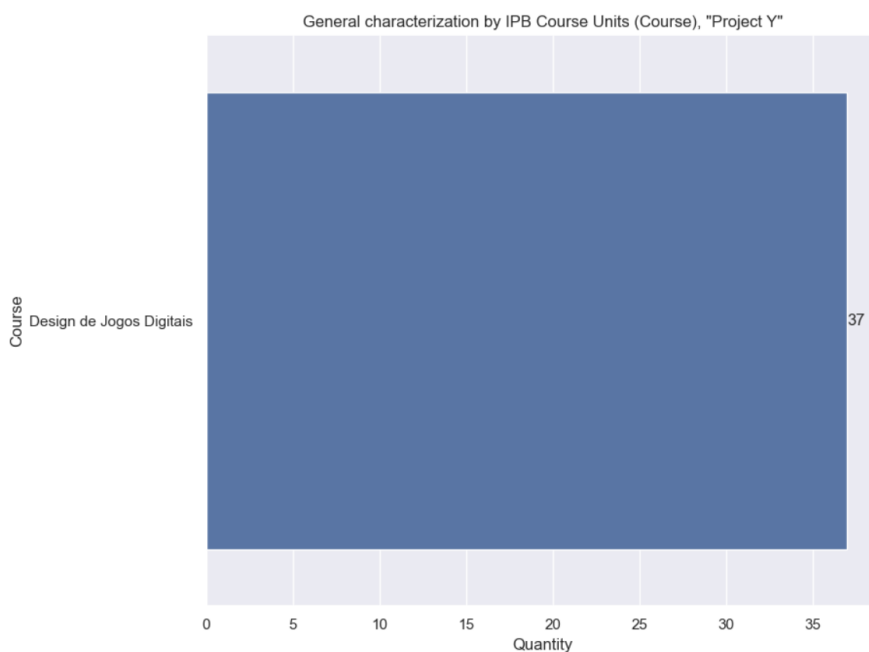

Figure 114: General characterization by IPB Course Units (Course), “Project Y”

The bar chart below shows the count of students in IPB course units. The Y-axis represents courses, and the X-axis represents the count of students.

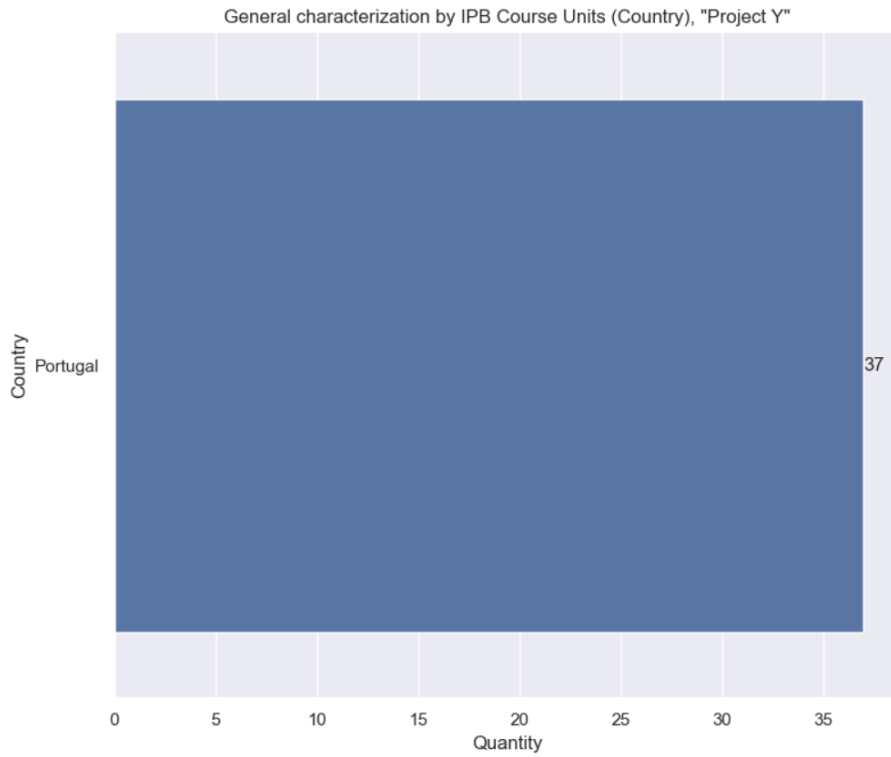

Figure 115: General characterization by IPB Course Units (Country), “Project Y”

The bar chart below shows the count of students in IPB course units. The Y-axis represents countries, and the X-axis represents the count of students.

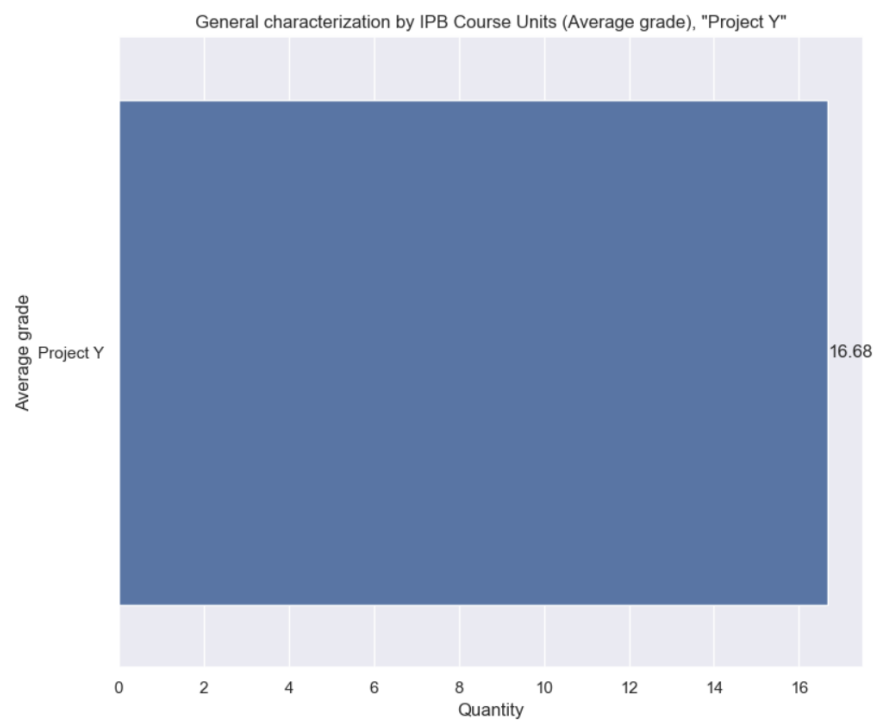

Figure 116: General characterization by IPB Course Units (Average grade), “Project Y”

The bar chart below shows the average grade in IPB course units. The Y-axis represents course unit, and the X-axis represents the average value.

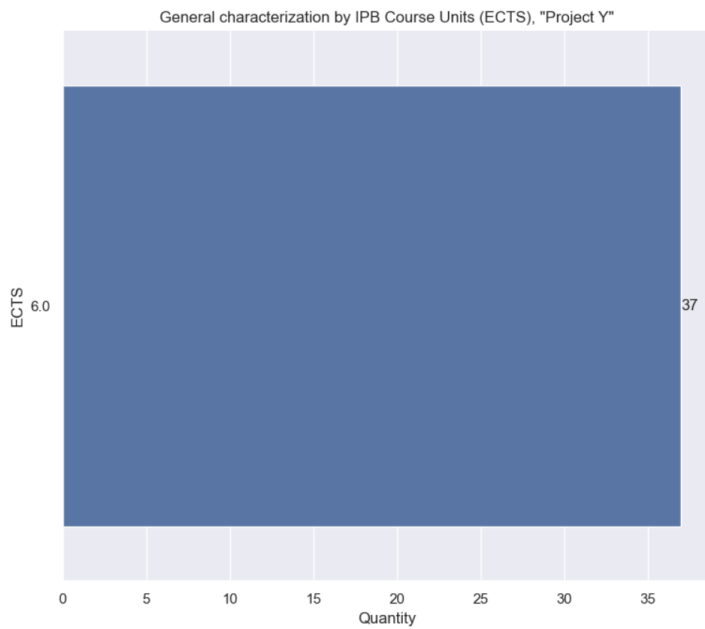

Figure 117: General characterization by IPB Course Units (ECTS), “Project Y”

The bar chart below shows the count of students in IPB course units. The Y-axis represents ECTS value, and the X-axis represents the count of students.

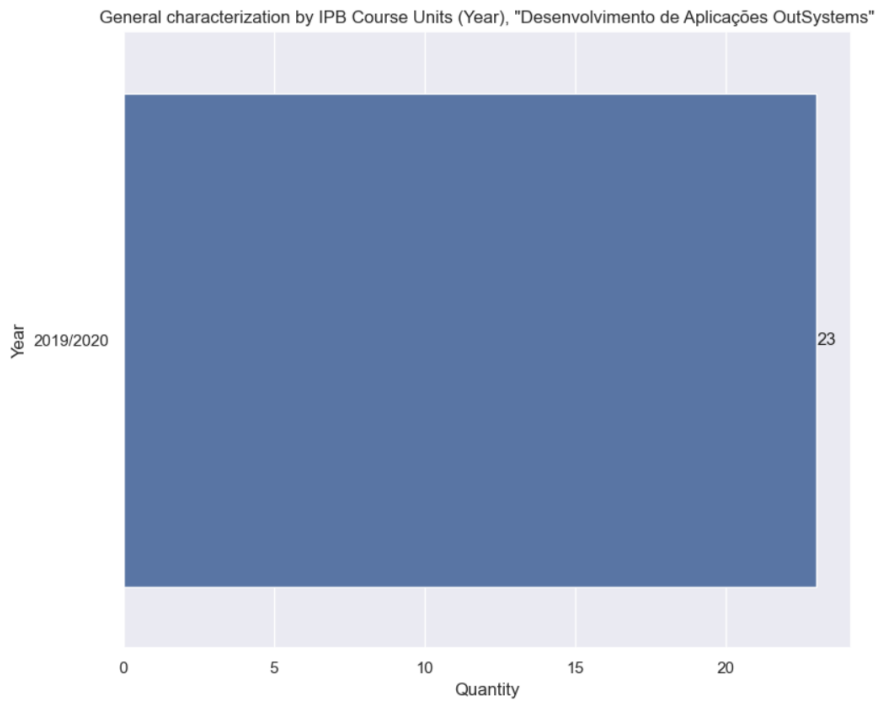

Figure 118: General characterization by IPB Course Units (Year), “Desenvolvimento de Aplicações OutSystems”

The bar chart below shows the count of students in IPB course units. The Y-axis represents years, and the X-axis represents the count of students.

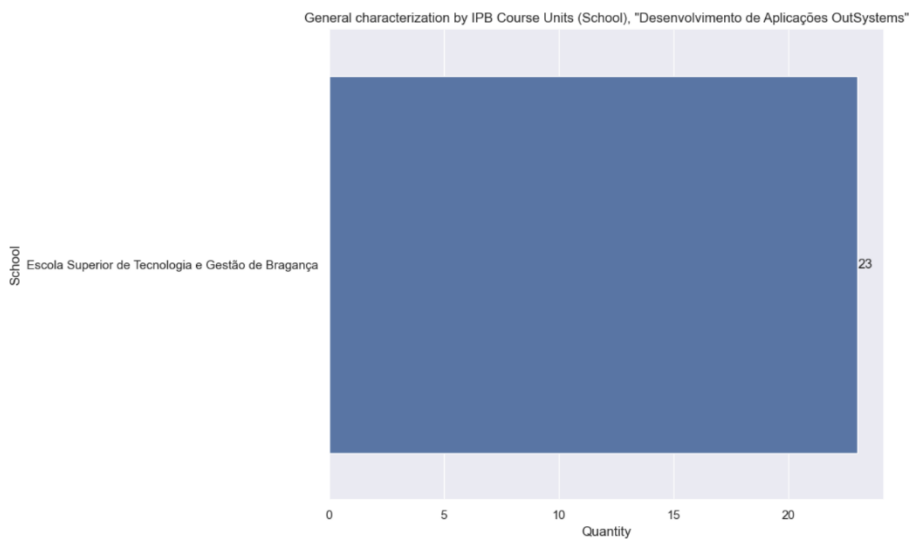

Figure 119: General characterization by IPB Course Units (School), “Desenvolvimento de Aplicações OutSystems”

The bar chart below shows the count of students in IPB course units. The Y-axis represents schools, and the X-axis represents the count of students.

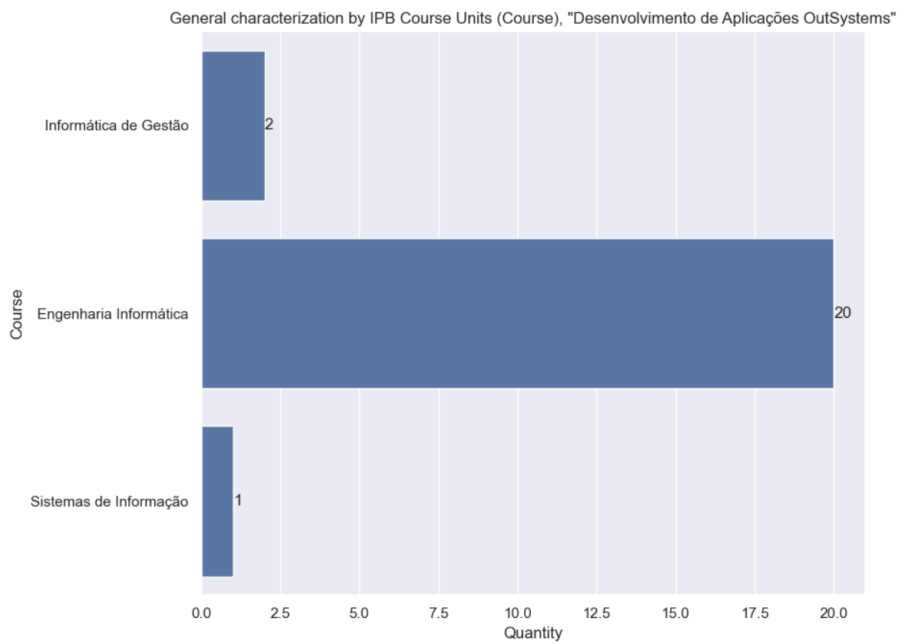

Figure 120: General characterization by IPB Course Units (Course), “Desenvolvimento de Aplicações OutSystems”

The bar chart below shows the count of students in IPB course units. The Y-axis represents courses, and the X-axis represents the count of students.

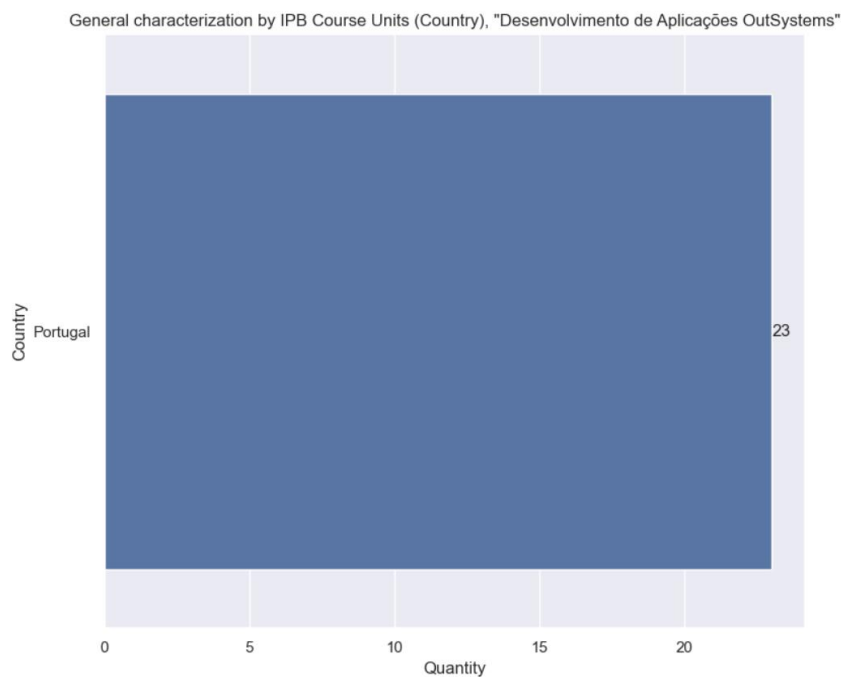

Figure 121: General characterization by IPB Course Units (Country), “Desenvolvimento de Aplicações OutSystems”

The bar chart below shows the count of students in IPB course units. The Y-axis represents countries, and the X-axis represents the count of students.

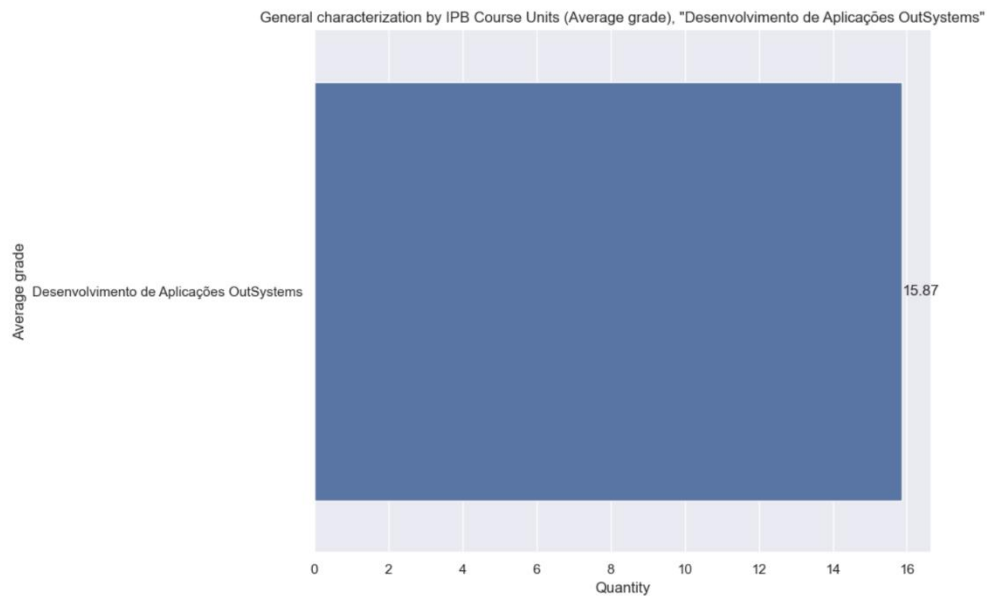

Figure 122: General characterization by IPB Course Units (Average grade), “Desenvolvimento de Aplicações OutSystems”

The bar chart below shows the average grade in IPB course units. The Y-axis represents course unit, and the X-axis represents the average grade.

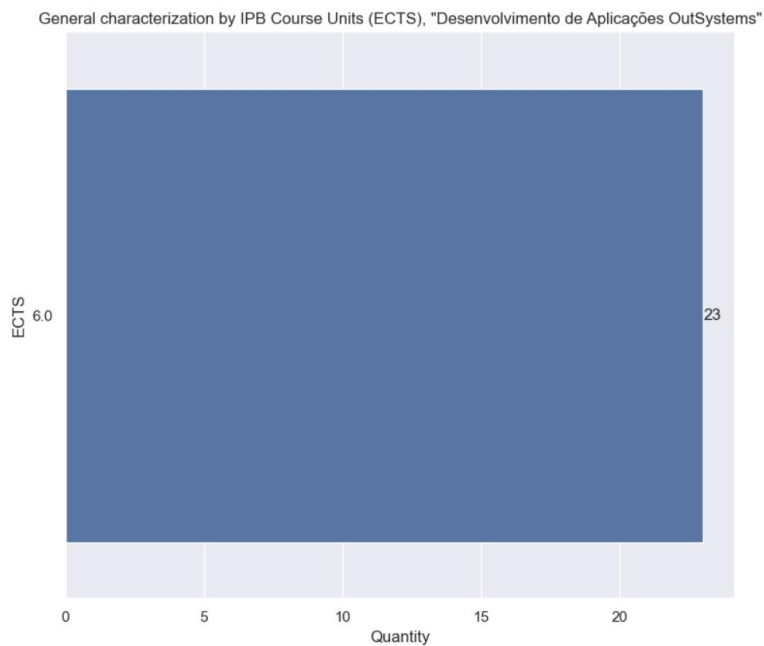

Figure 123: General characterization by IPB Course Units (ECTS), “Desenvolvimento de Aplicações OutSystems”

The bar chart below shows the count of students in IPB course units. The Y-axis represents ECTS values, and the X-axis represents the count of students.

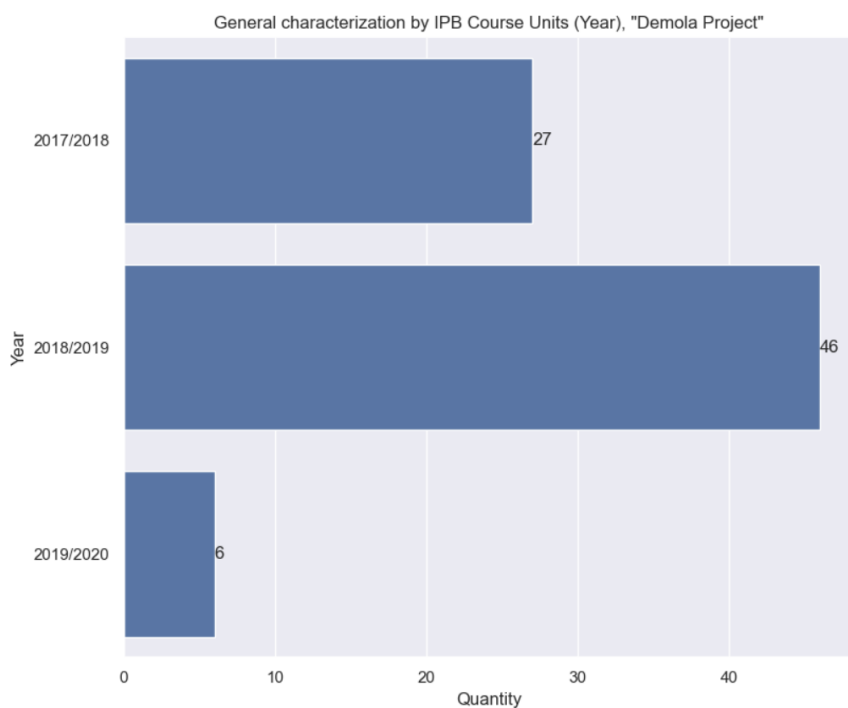

Figure 124: General characterization by IPB Course Units (Year), “Demola Project”

The bar chart below shows the count of students in IPB course units. The Y-axis represents years, and the X-axis represents the count of students.

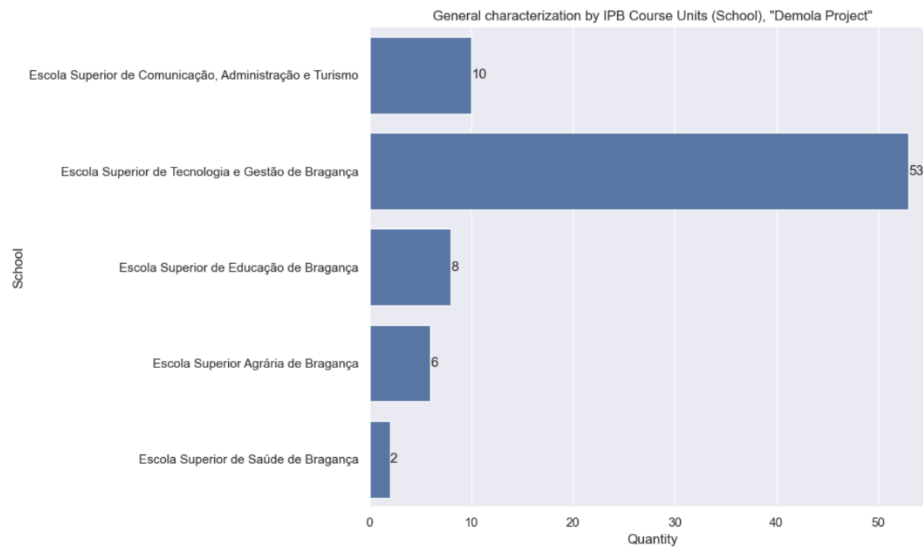

Figure 125: General characterization by IPB Course Units (School), “Demola Project”

The bar chart below shows the count of students in IPB course units. The Y-axis represents schools, and the X-axis represents the count of students.

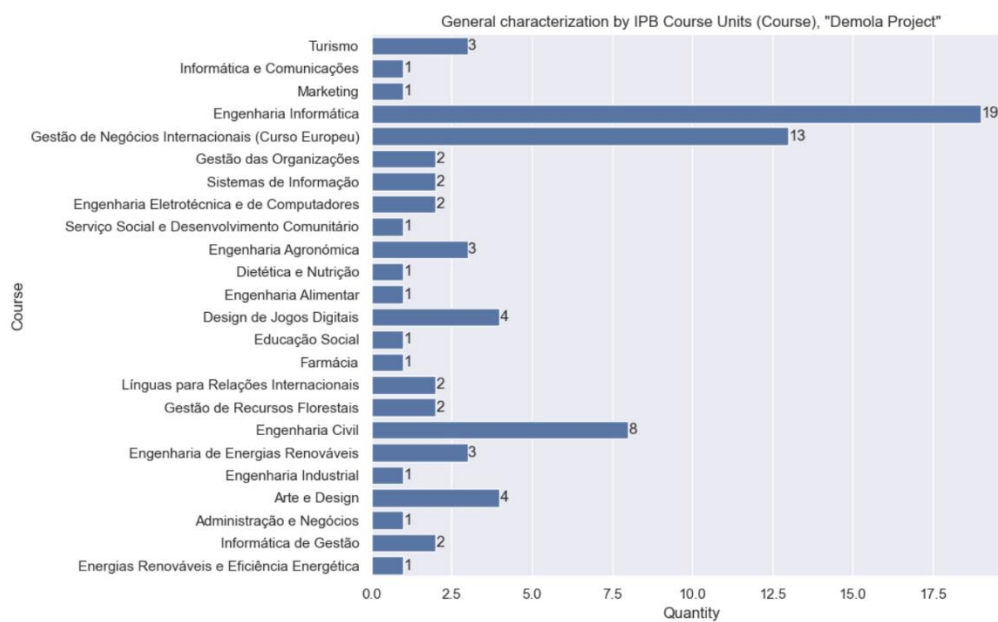

Figure 126: General characterization by IPB Course Units (Course), “Demola Project”

The bar chart below shows the count of students in IPB course units. The Y-axis represents courses, and the X-axis represents the count of students.

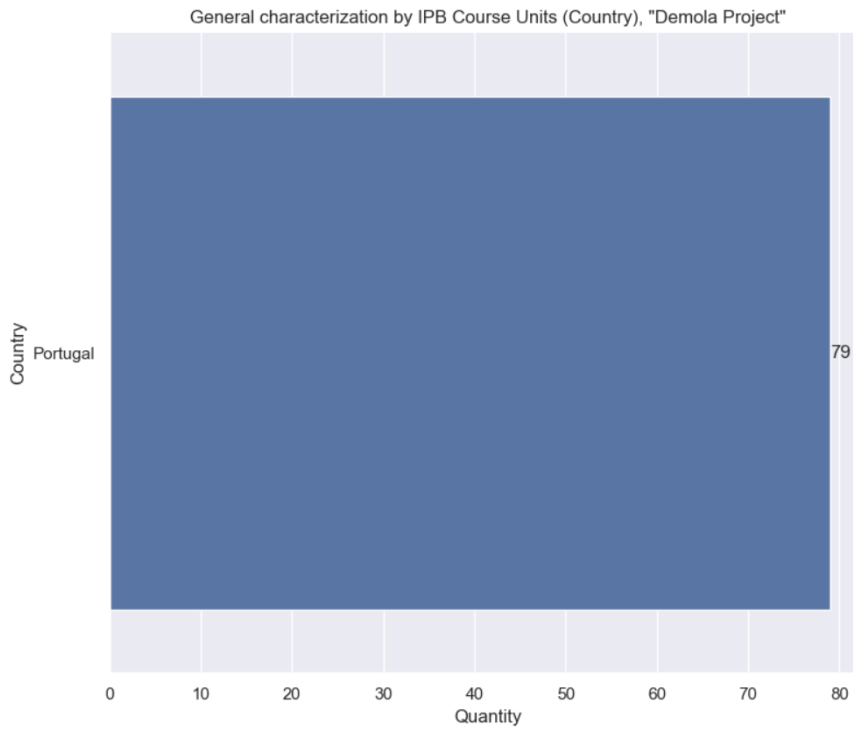

Figure 127: General characterization by IPB Course Units (Country), “Demola Project”

The bar chart below shows the count of students in IPB course units. The Y-axis represents countries, and the X-axis represents the count of students.

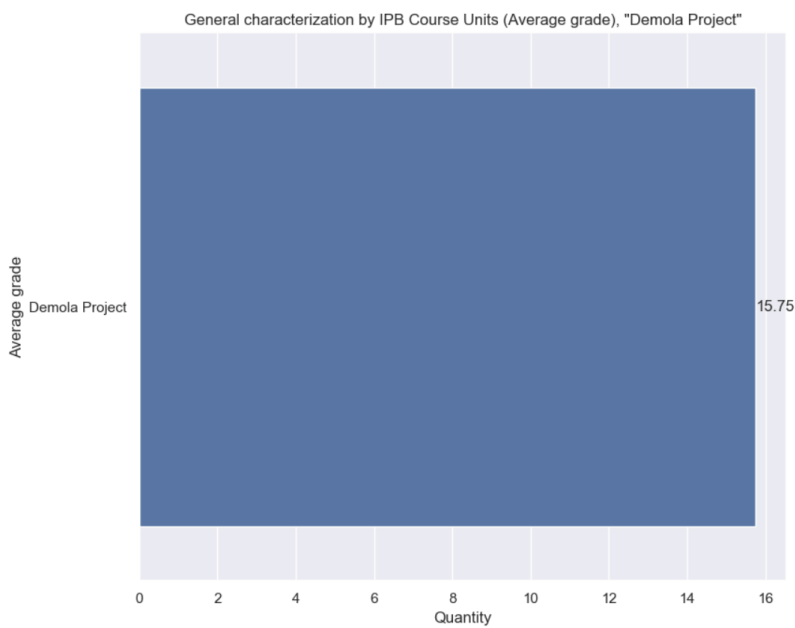

Figure 128: General characterization by IPB Course Units (Average grade), “Demola Project”

The bar chart below shows the average grade in IPB course units. The Y-axis represents course unit, and the X-axis represents the average value.

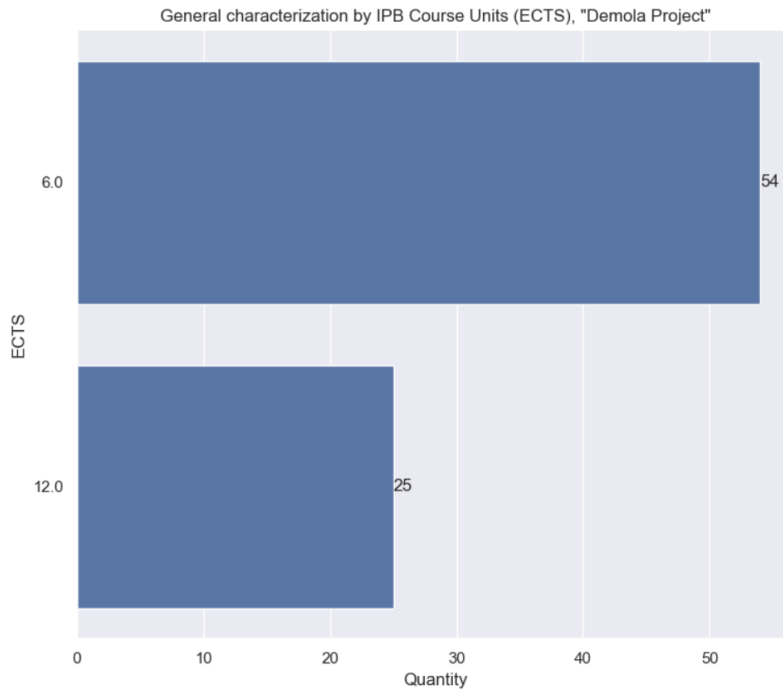

Figure 129: General characterization by IPB Course Units (ECTS), “Demola Project”

The bar chart below shows the count of students in IPB course units. The Y-axis represents ECTS values, and the X-axis represents the count of students.

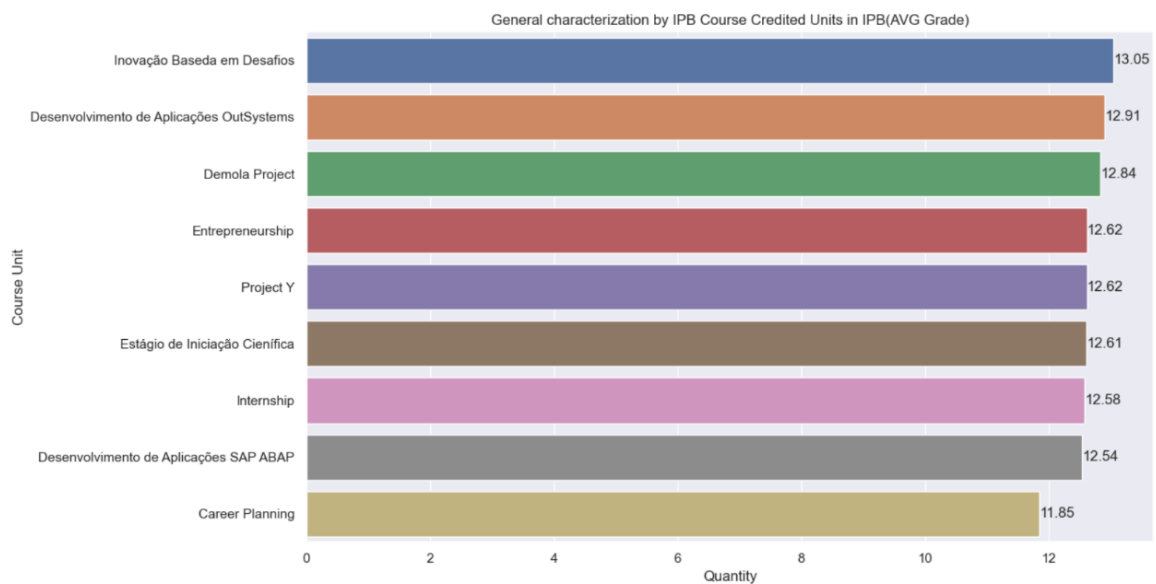

Figure 130: General characterization by IPB Course Credited Units (Average grade)

The bar chart below shows the average value in different course units. The Y-axis represents course units, and the X-axis represents the average value. The highest average score was in Inovação Baseda em Desafios at 13.05, and the lowest average score was in Career Planning at 11.85.

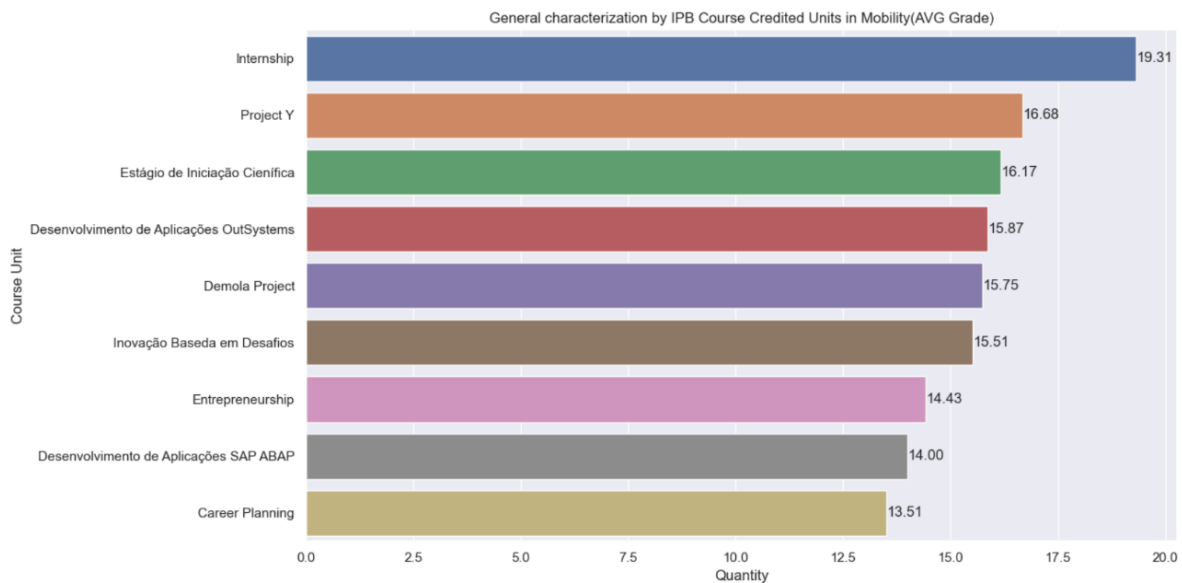

Figure 131: General characterization by IPB Course Credited Units in Mobility (Average grade)

The bar chart below shows the average value in different course units in mobility. The Y-axis represents course units, and the X-axis represents the average value. The highest average score was in Internship at 19.31, and the lowest average score was in Career Planning at 13.51.

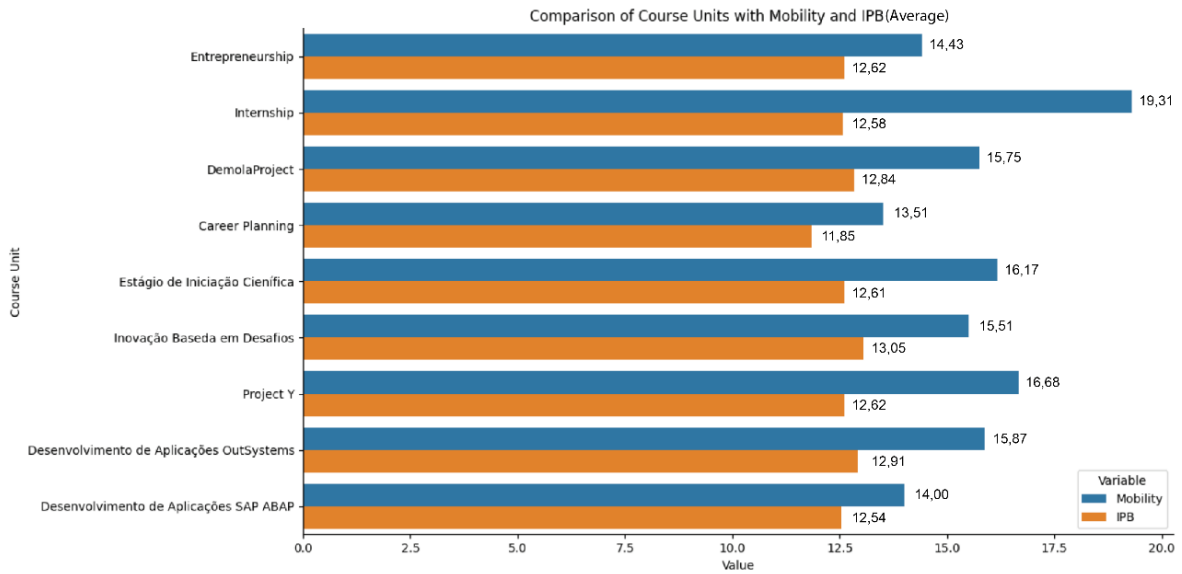

Figure 132: Comparison of average values of course units in the IPB and in the Mobility (Average grade)

The bar chart below shows the average value in different course units. The Y-axis represents course units, and the X-axis represents the average value.

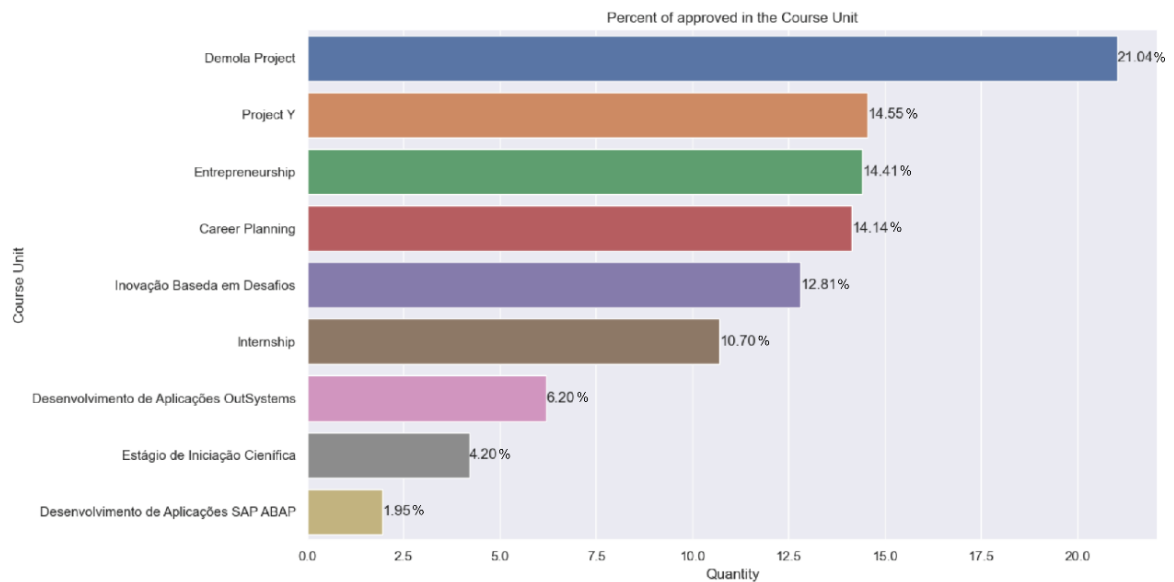

Figure 133: Percent of approved in the Course Unit

The bar chart below shows the average percent of approved in different course units. The Y-axis represents course units, and the X-axis represents the average value. The highest percent

of approved in Demola Project at 21.04%, and the lowest average score was in Desenvolvimento de Aplicações SAP ABAP at 1.95%.

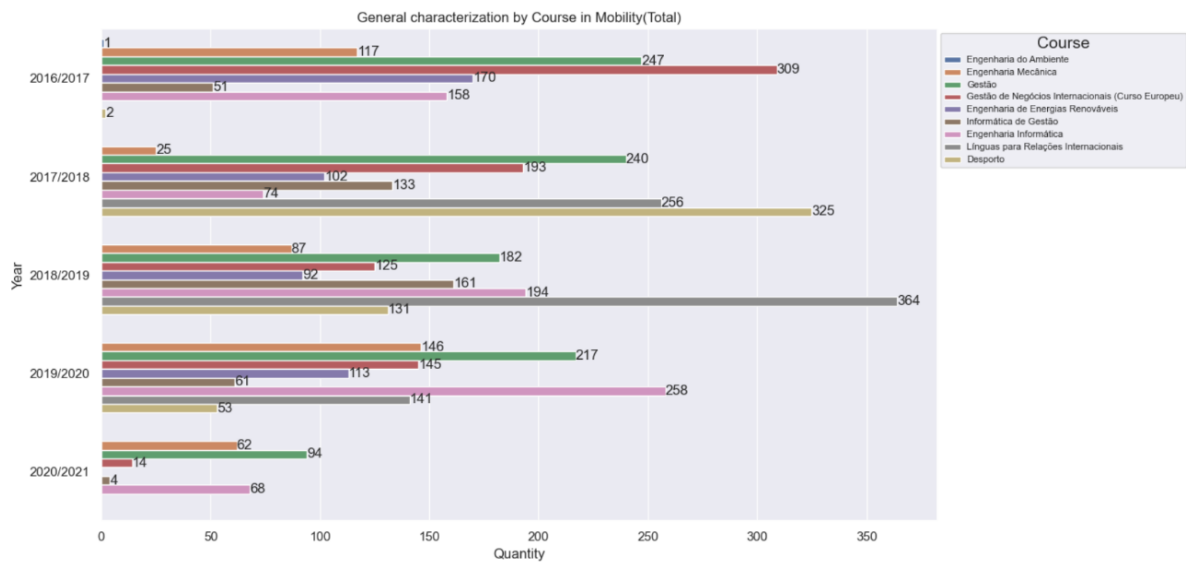

Figure 134: General characterization by Course in Mobility(Total)

The bar chart below shows the count of students in Mobility. The Y-axis represents years, and the X-axis represents the count of students.

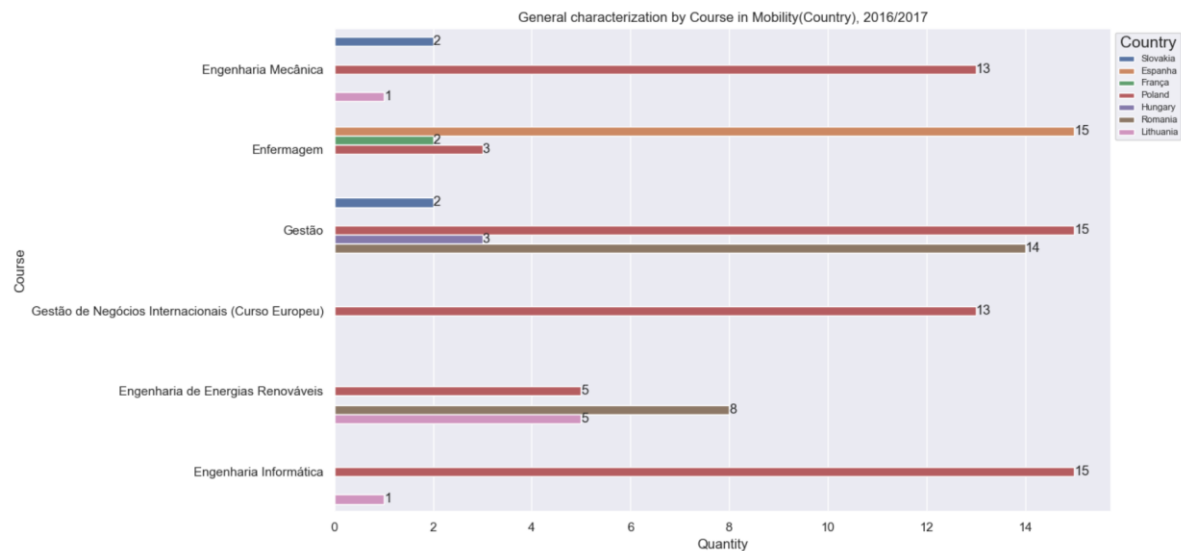

Figure 135: General characterization by Course in Mobility(Country), 2016/2017

The bar chart below shows the variables with the maximum number of students are shown in Mobility. The Y-axis represents courses, and the X-axis represents the count of students.

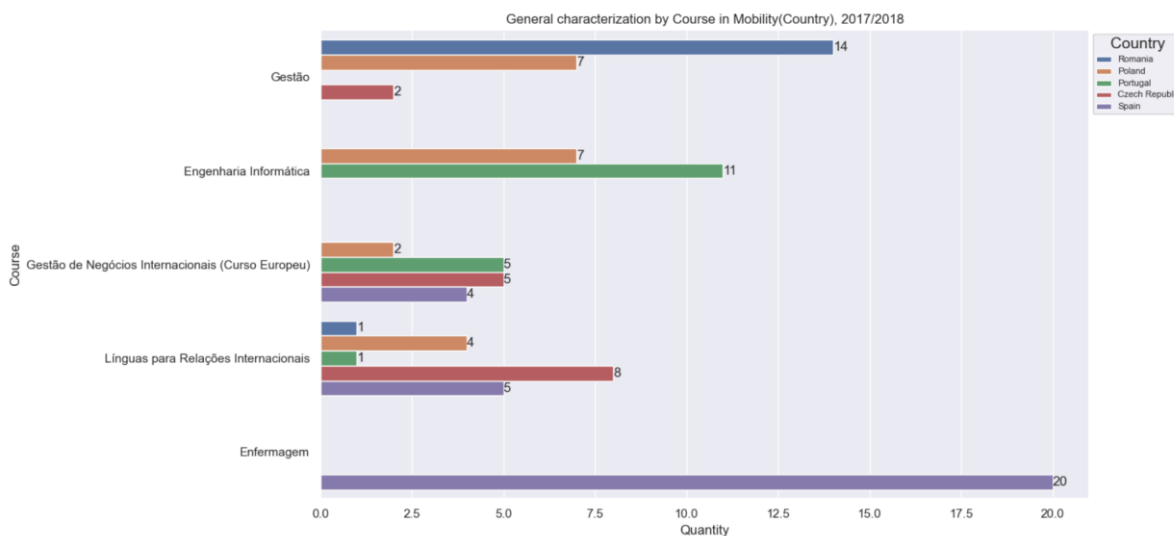

Figure 136: General characterization by Course in Mobility(Country), 2017/2018

The bar chart below shows the variables with the maximum number of students are shown in Mobility. The Y-axis represents courses, and the X-axis represents the count of students.

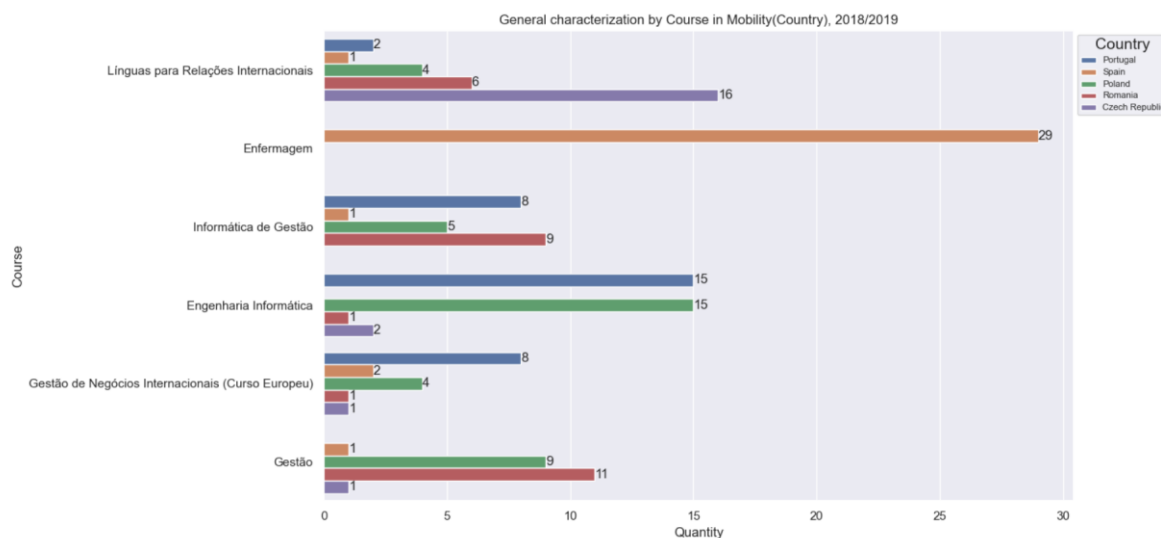

Figure 137: General characterization by Course in Mobility(Country), 2018/2019

The bar chart below shows the variables with the maximum number of students are shown in Mobility. The Y-axis represents courses, and the X-axis represents the count of students.

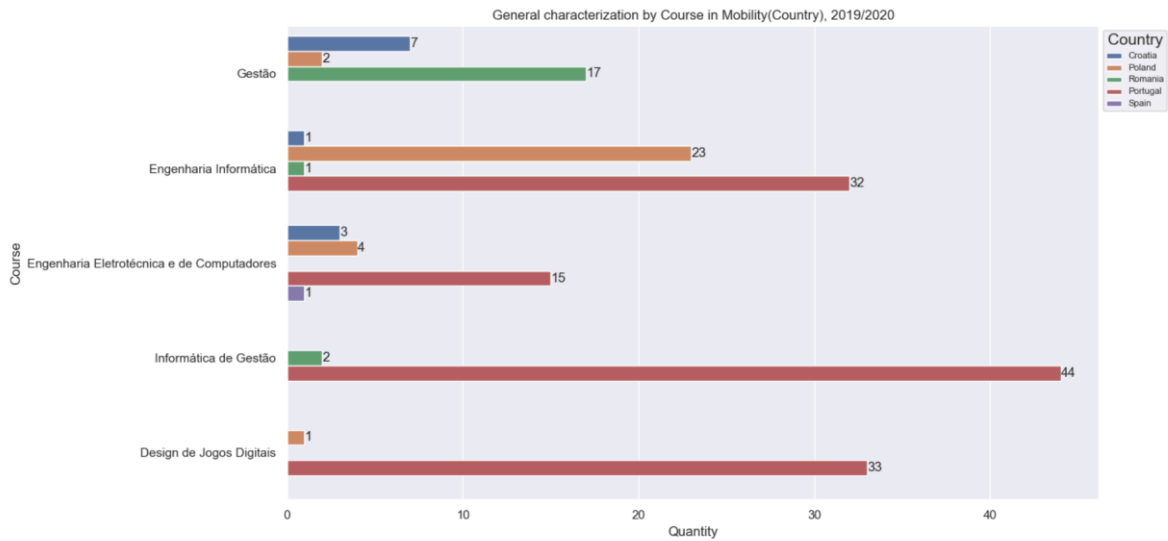

Figure 138: General characterization by Course in Mobility(Country), 2019/2020

The bar chart below shows the variables with the maximum number of students are shown in Mobility. The Y-axis represents courses, and the X-axis represents the count of students.

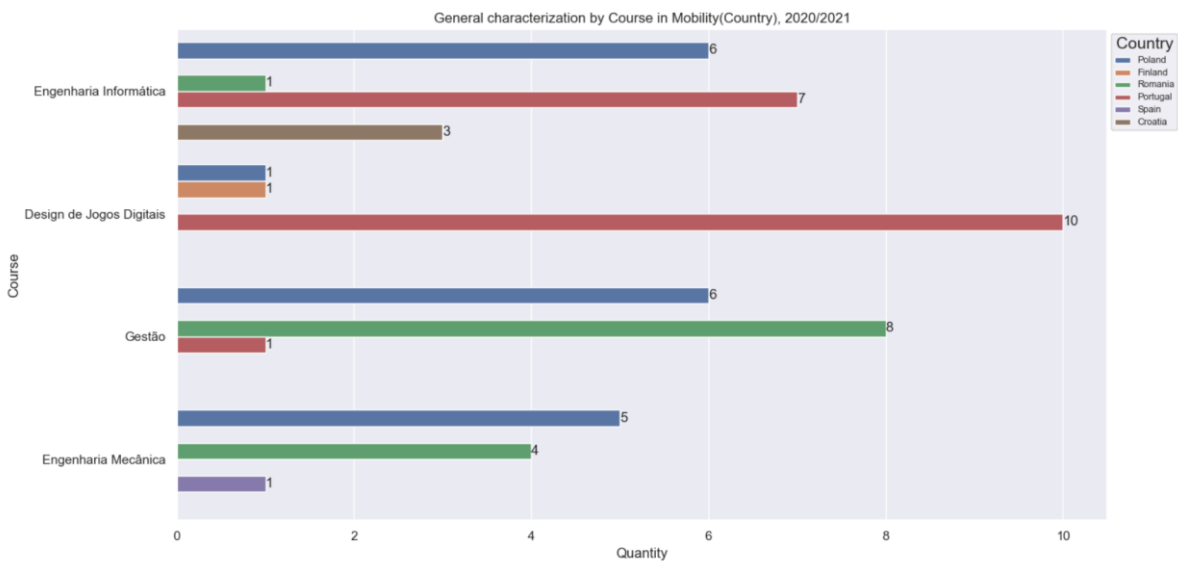

Figure 139: General characterization by Course in Mobility(Country), 2020/2021

The bar chart below shows the variables with the maximum number of students are shown in Mobility. The Y-axis represents courses, and the X-axis represents the count of students.

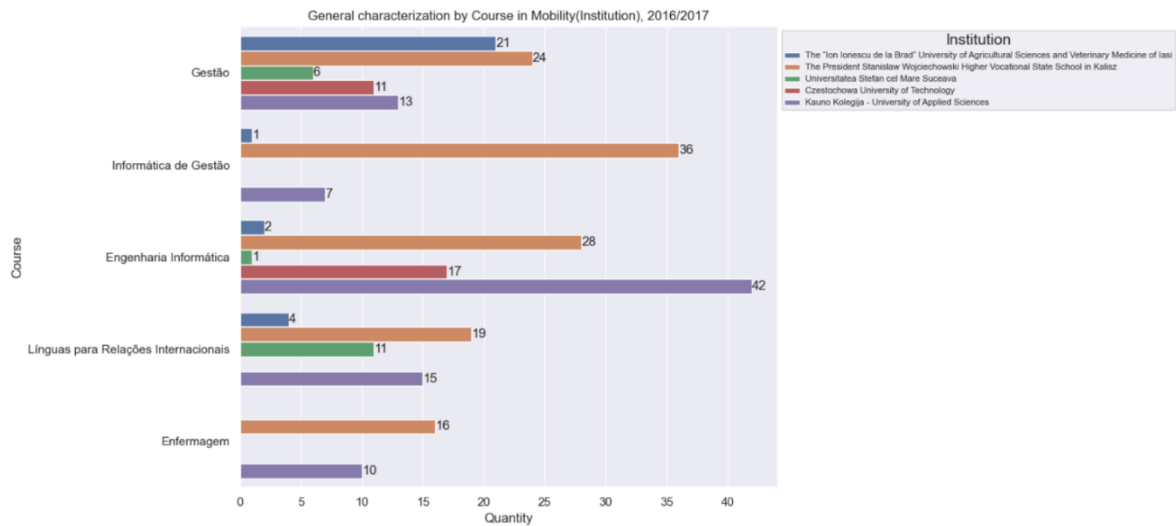

Figure 140: General characterization by Course in Mobility(Institution), 2016/2017

The bar chart below shows the variables with the maximum number of students are shown in Mobility. The Y-axis represents courses, and the X-axis represents the count of students.

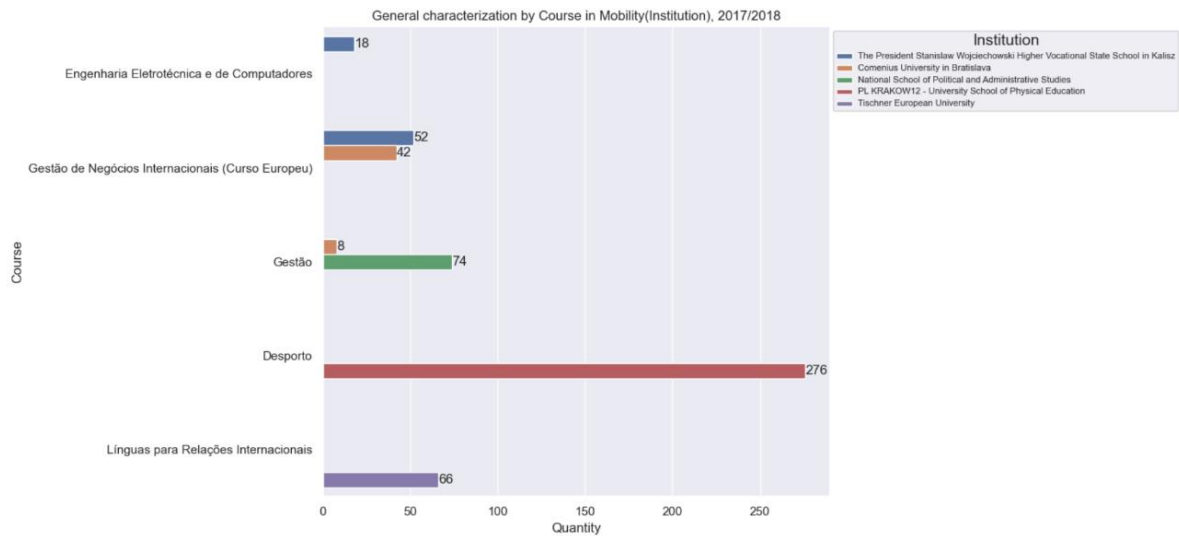

Figure 141: General characterization by Course in Mobility(Institution), 2017/2018

The bar chart below shows the variables with the maximum number of students are shown in Mobility. The Y-axis represents courses, and the X-axis represents the count of students.

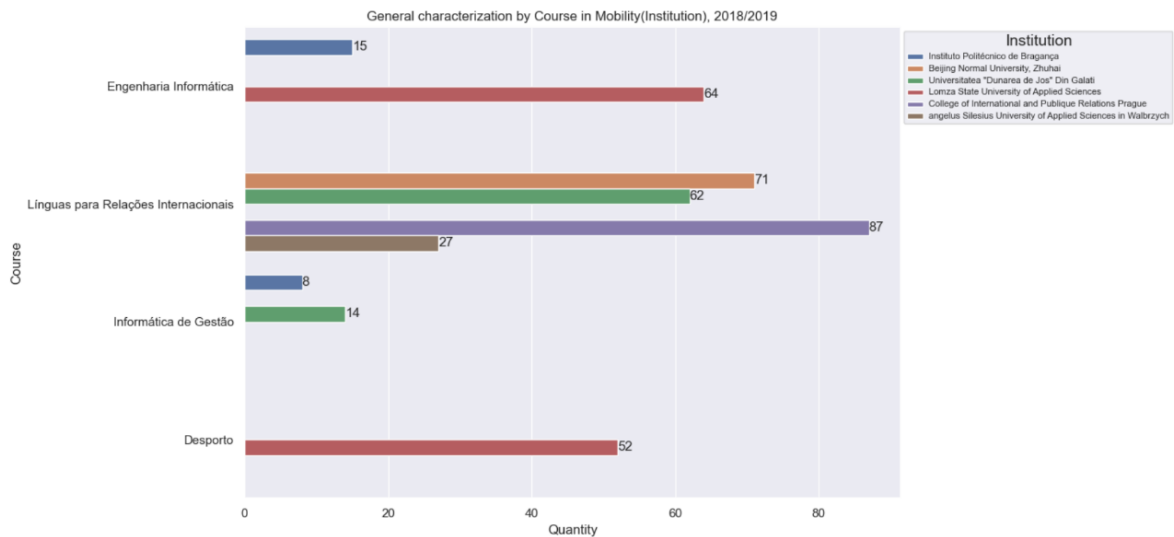

Figure 142: General characterization by Course in Mobility(Institution), 2018/2019

The bar chart below shows the variables with the maximum number of students are shown in Mobility. The Y-axis represents courses, and the X-axis represents the count of students.

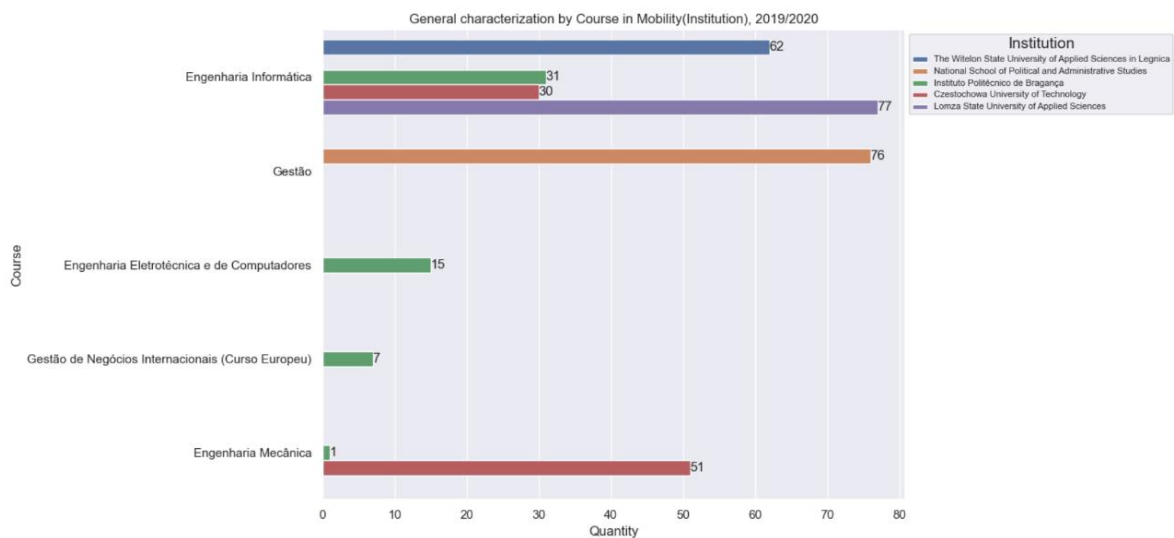

Figure 143: General characterization by Course in Mobility(Institution), 2019/2020

The bar chart below shows the variables with the maximum number of students are shown in Mobility. The Y-axis represents courses, and the X-axis represents the count of students.

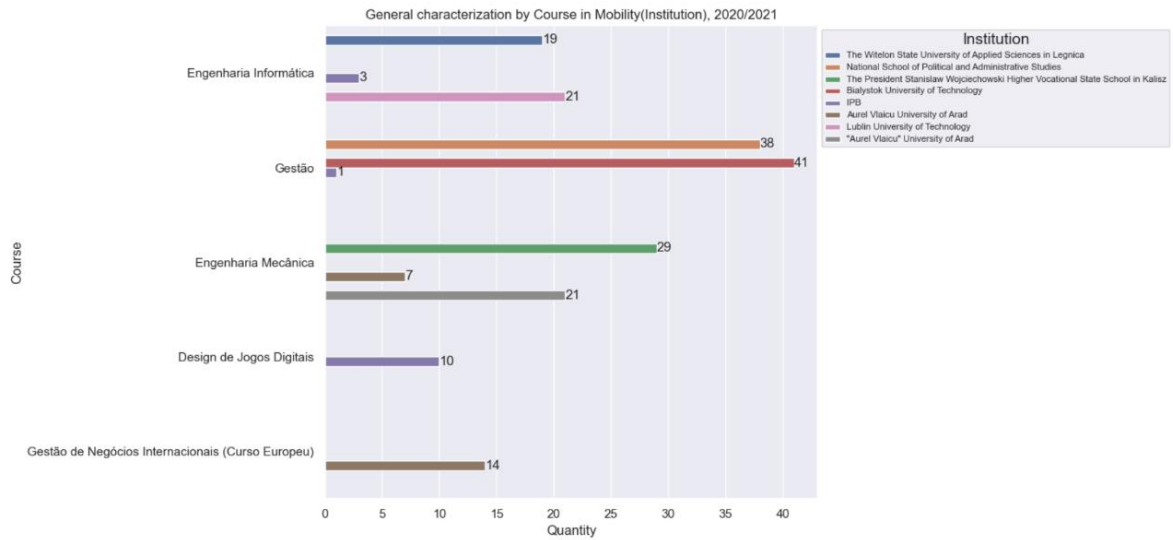

Figure 144: General characterization by Course in Mobility(Institution), 2020/2021

The bar chart below shows the variables with the maximum number of students are shown in Mobility. The Y-axis represents courses, and the X-axis represents the count of students.

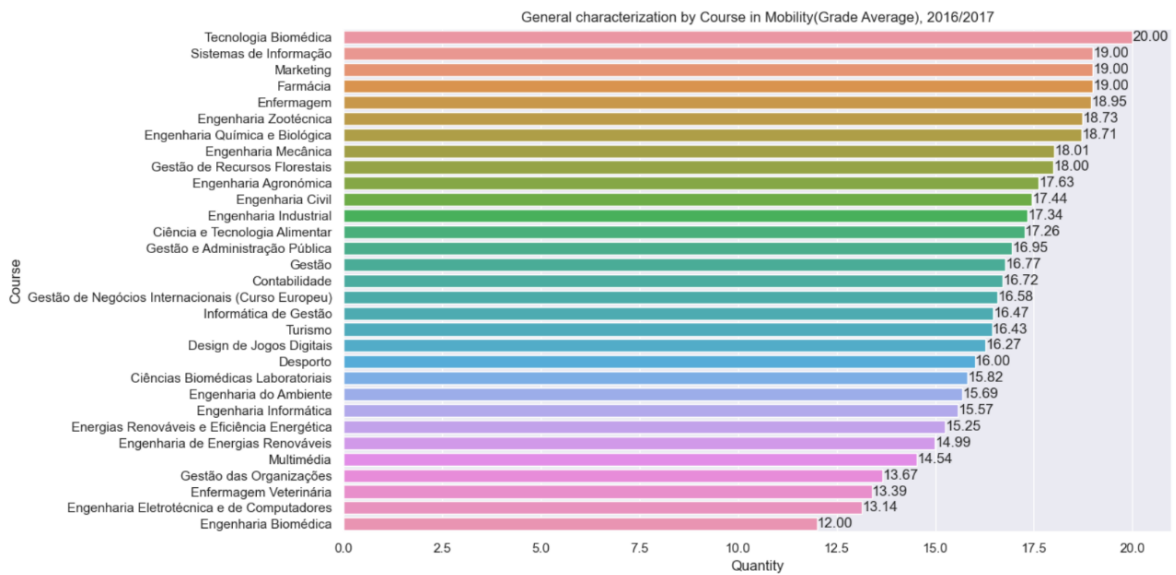

Figure 145: General characterization by Course in Mobility (Average Grade), 2016/2017

The bar chart below shows the average in different courses. The Y-axis represents courses, and the X-axis represents the average value. The highest average score was in Tecnologia Biomédica at 20.00, and the lowest average score was in Engenharia Biomédica at 12.00.

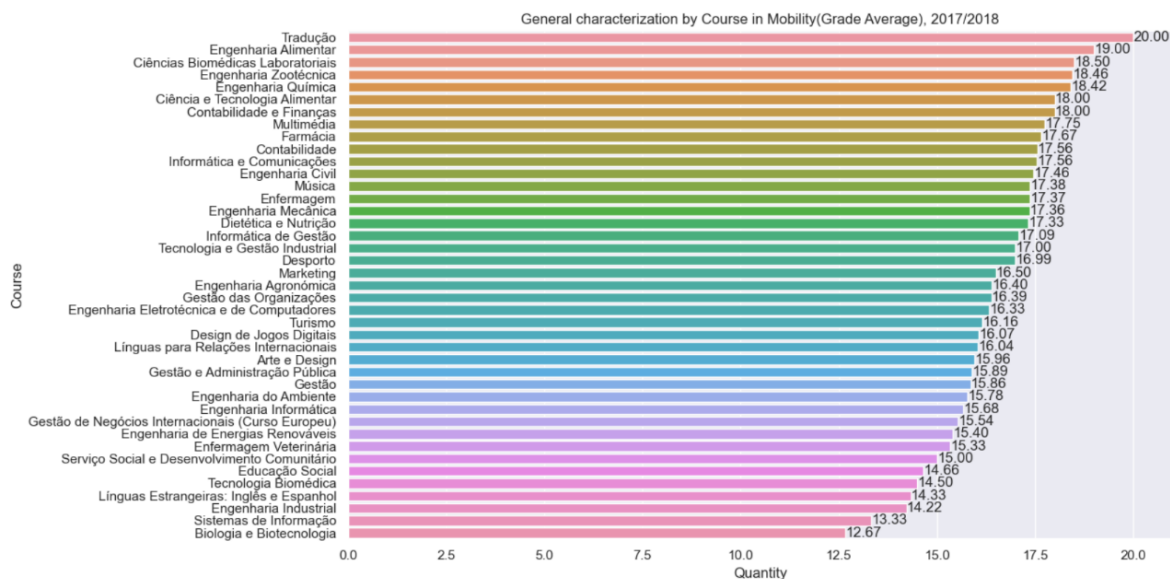

Figure 146: General characterization by Course in Mobility (Average Grade), 2017/2018

The bar chart below shows the average in different courses. The Y-axis represents courses, and the X-axis represents the average value. The highest average score was in Tradução at 20.00, and the lowest average score was in Biologia e Biotecnologia at 12.67.

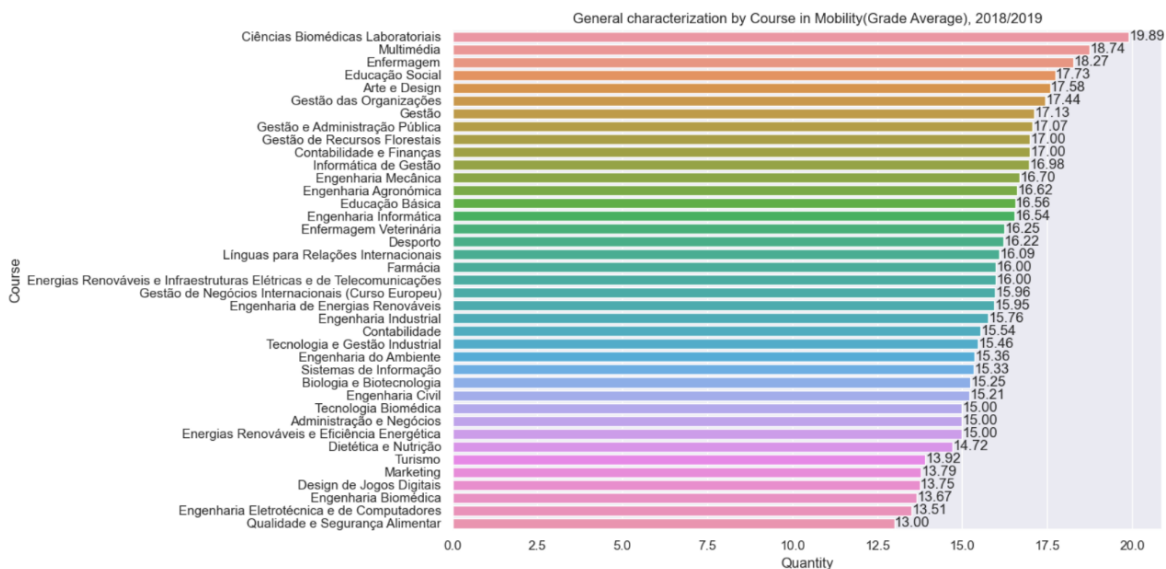

Figure 147: General characterization by Course in Mobility (Average Grade), 2018/2019

The bar chart below shows the average in different courses. The Y-axis represents courses, and the X-axis represents the average value. The highest average score was in Ciências Biomédicas Laboratoriais at 19.89, and the lowest average score was in Qualidade e Segurança Alimentar at 13.00.

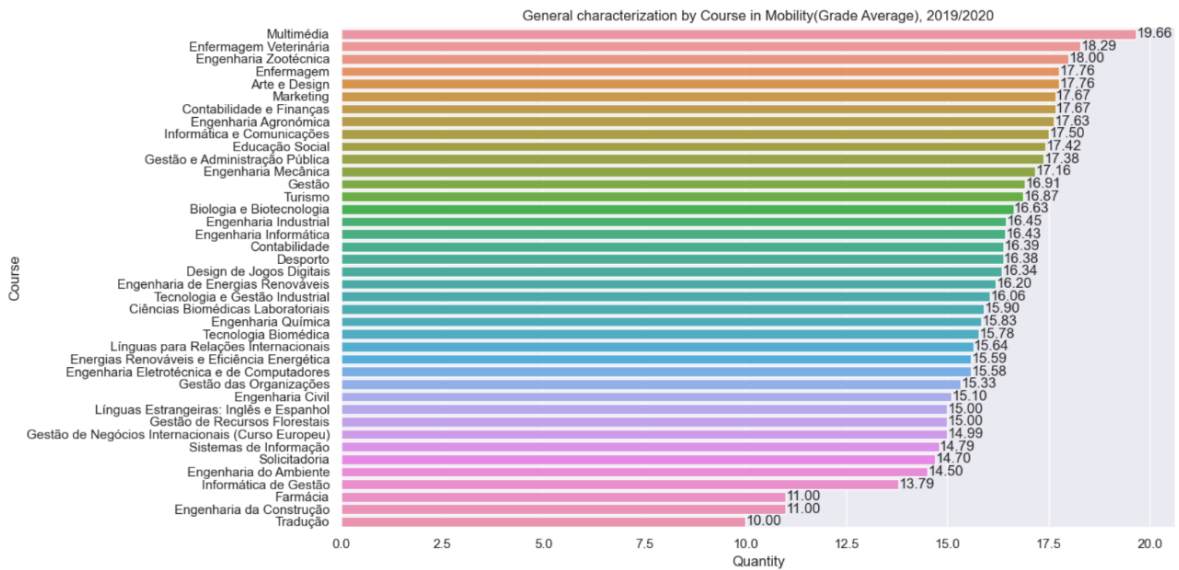

Figure 148: General characterization by Course in Mobility (Average Grade), 2019/2020

The bar chart below shows the average in different courses. The Y-axis represents courses, and the X-axis represents the average value. The highest average score was in Multimédia at 19.66, and the lowest average score was in Tradução at 10.00.

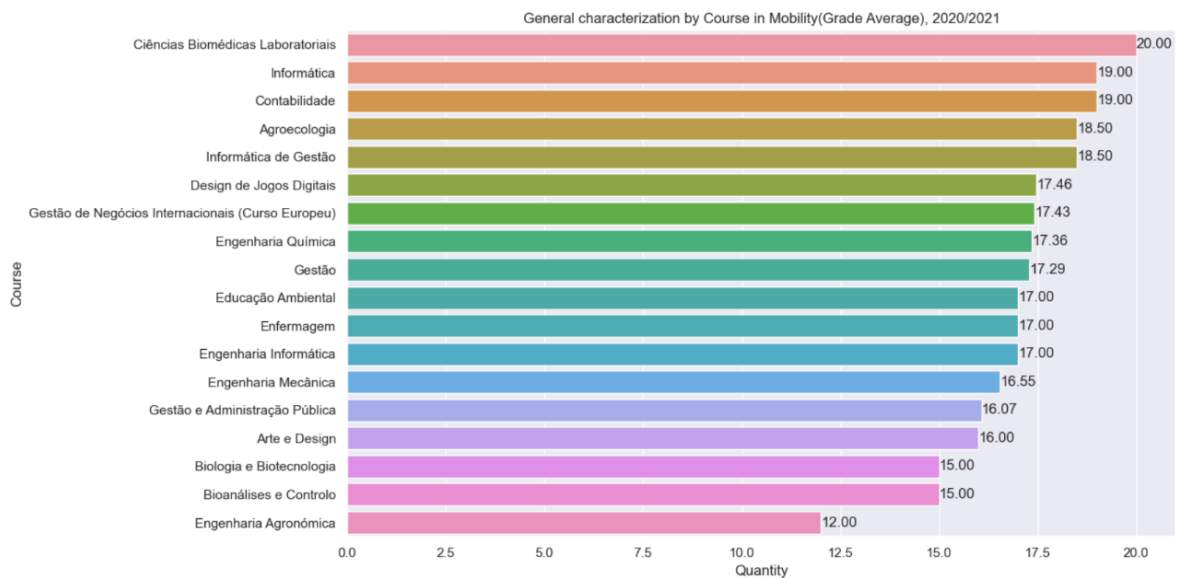

Figure 149: General characterization by Course in Mobility (Average Grade), 2020/2021

The bar chart below shows the average in different courses. The Y-axis represents courses, and the X-axis represents the average value. The highest average score was in Ciências Biomédicas Laboratoriais at 20.00, and the lowest average score was in Engenharia Agronómica at 12.00.

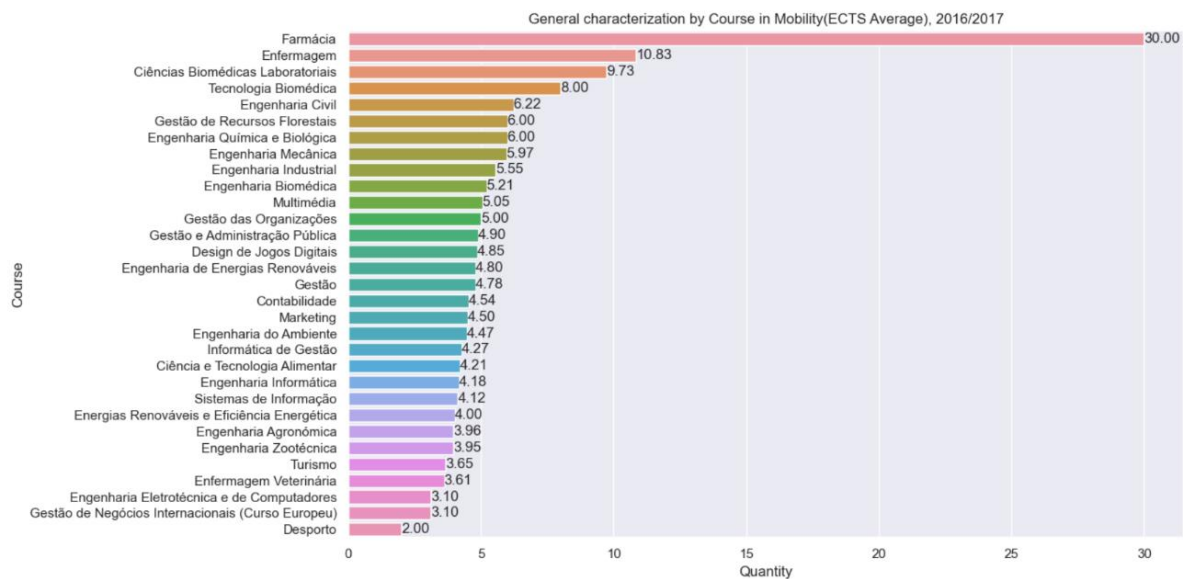

Figure 150: General characterization by Course in Mobility (ECTS Average), 2016/2017

The bar chart below shows the ECTS average in different courses. The Y-axis represents courses, and the X-axis represents the average value. The highest average score was in Farmácia at 30.00, and the lowest average score was in Desporto at 2.00.

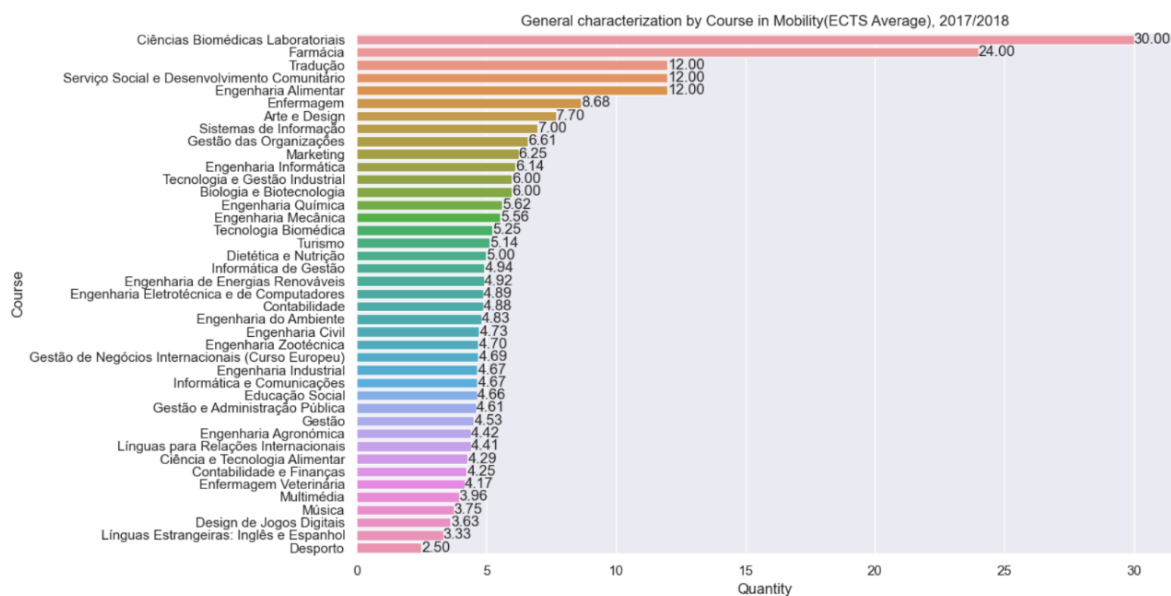

Figure 151: General characterization by Course in Mobility (ECTS Average), 2017/2018

The bar chart below shows the ECTS average in different courses. The Y-axis represents courses, and the X-axis represents the average value. The highest average score was in Ciências Biomédicas Laboratoriais at 30.00, and the lowest average score was in Desporto at 2.50.

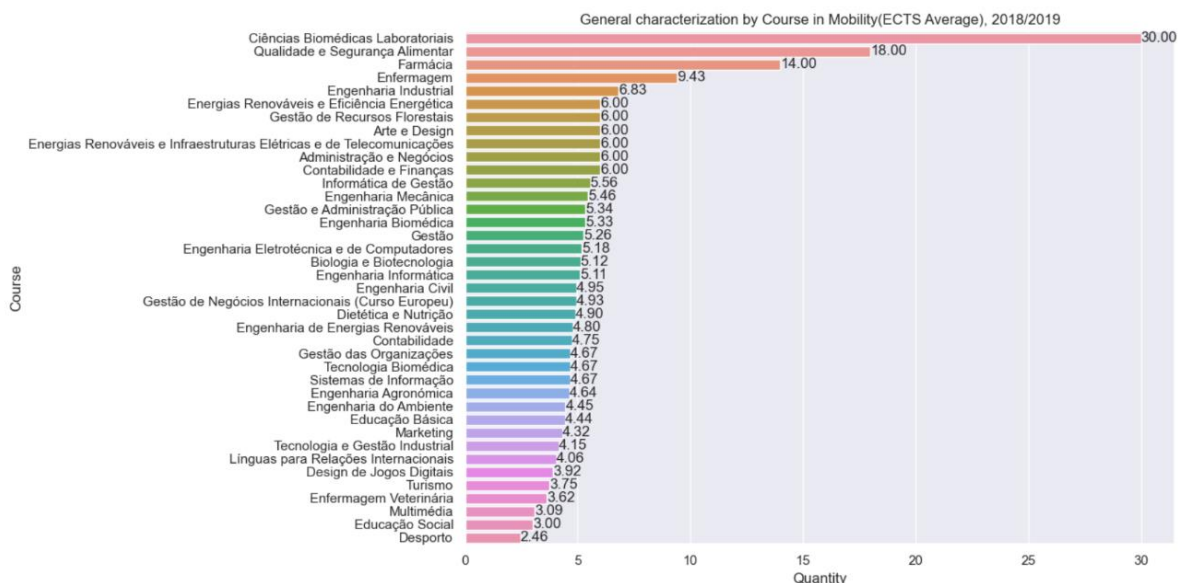

Figure 152: General characterization by Course in Mobility (ECTS Average), 2018/2019

The bar chart below shows the ECTS average in different courses. The Y-axis represents courses, and the X-axis represents the average value. The highest average score was in Ciências Biomédicas Laboratoriais at 30.00, and the lowest average score was in Desporto at 2.46.

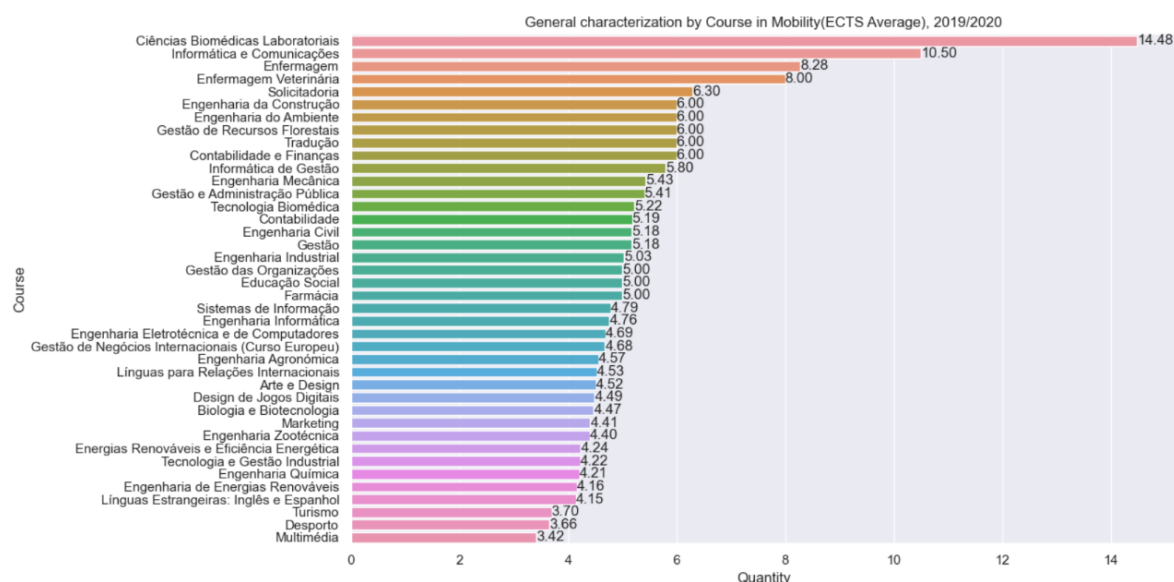

Figure 153: General characterization by Course in Mobility (ECTS Average), 2019/2020

The bar chart below shows the ECTS average in different courses. The Y-axis represents courses, and the X-axis represents the average value. The highest average score was in Ciências Biomédicas Laboratoriais at 14.48, and the lowest average score was in Multimédia at 3.42.

Ciências Biomédicas Laboratoriais at 14.48, and the lowest average score was in Multimédia at 3.42.

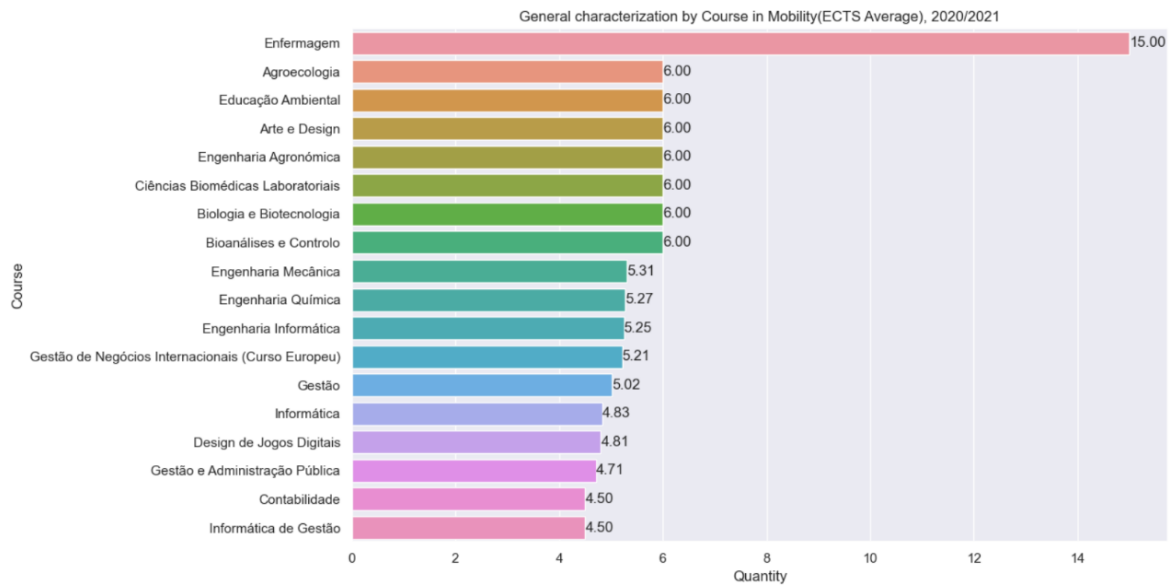

Figure 154: General characterization by Course in Mobility (ECTS Average), 2020/2021

The bar chart below shows the ECTS average in different courses. The Y-axis represents courses, and the X-axis represents the average value. The highest average score was in Enfermagem at 15.00, and the lowest average score was in Informática de Gestão at 4.50.

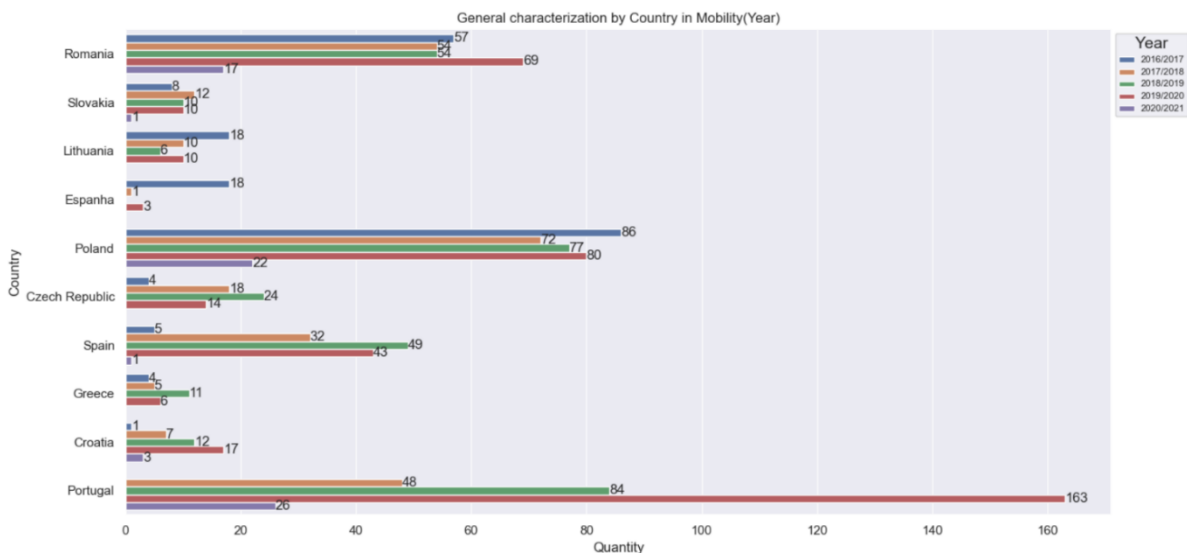

Figure 155: General characterization by Country in Mobility(Total)

The bar chart below shows the count of students in Mobility. The Y-axis represents years, and the X-axis represents the count of students.

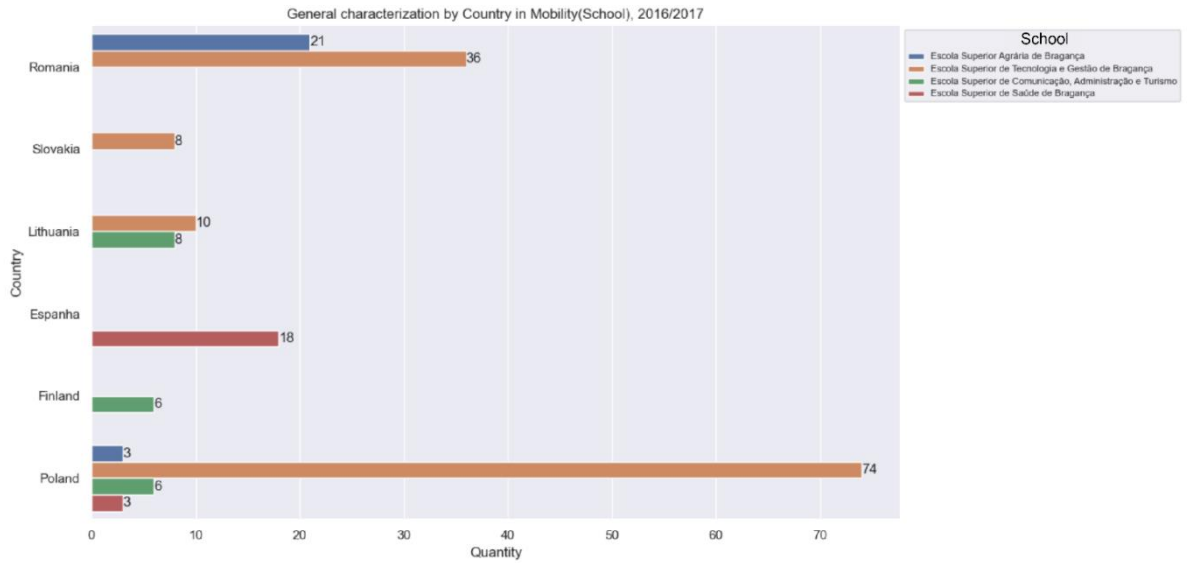

Figure 156: General characterization by Country in Mobility(School), 2016/2017

The bar chart below shows the count of students in Mobility. The Y-axis represents countries, and the X-axis represents the count of students.

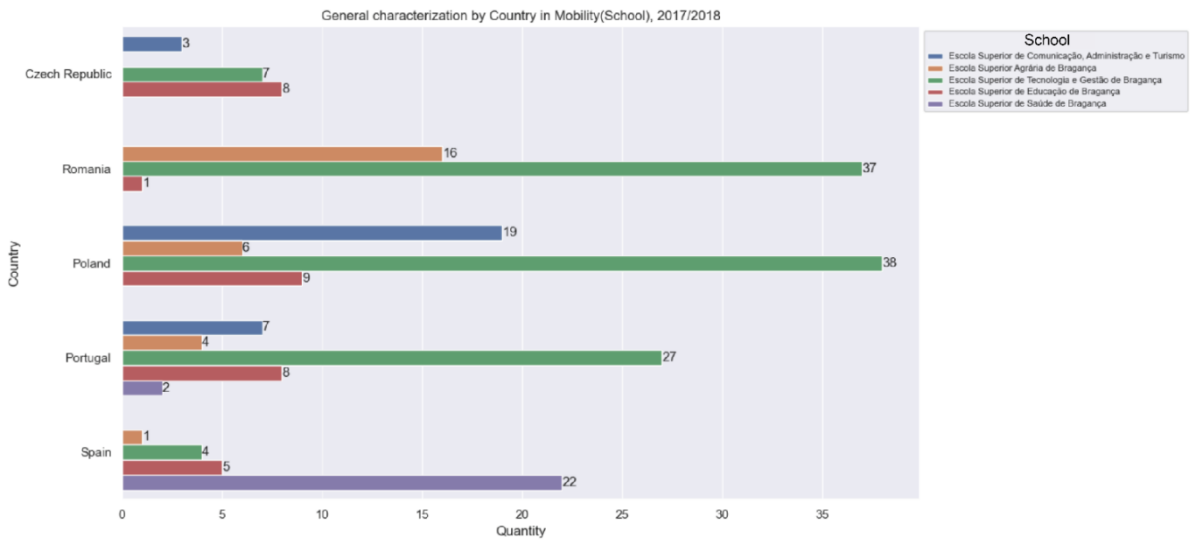

Figure 157: General characterization by Country in Mobility(School), 2017/2018

The bar chart below shows the count of students in Mobility. The Y-axis represents countries, and the X-axis represents the count of students.

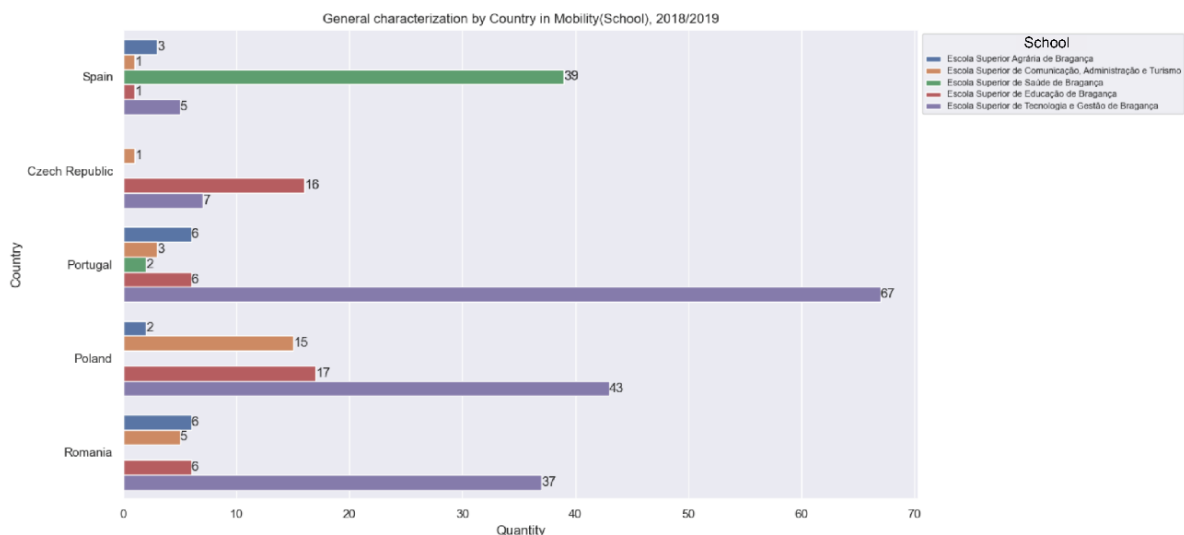

Figure 158: General characterization by Country in Mobility(School), 2018/2019

The bar chart below shows the count of students in Mobility. The Y-axis represents countries, and the X-axis represents the count of students.

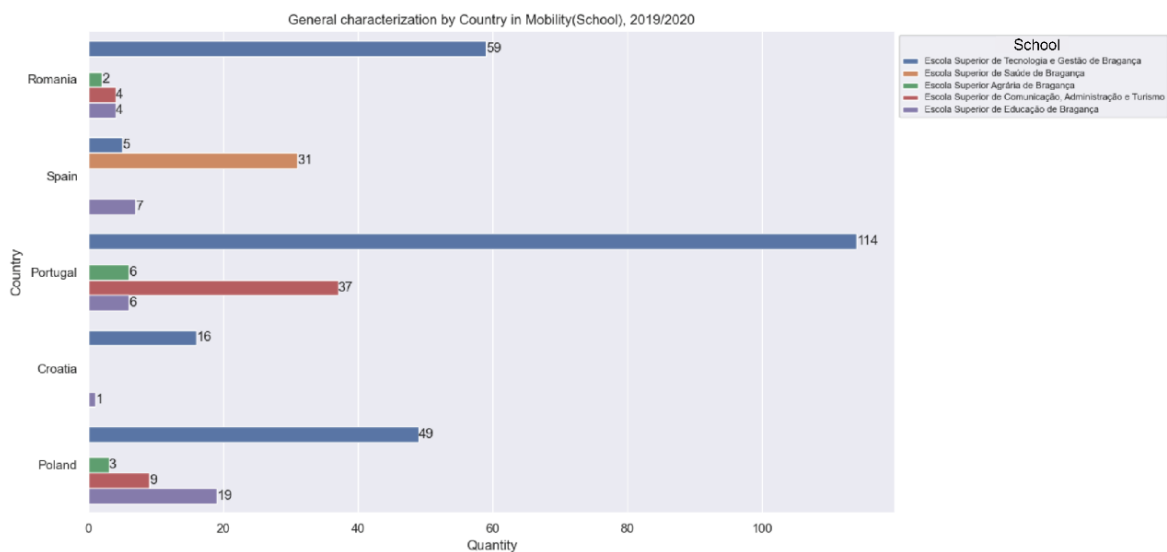

Figure 159: General characterization by Country in Mobility(School), 2019/2020

The bar chart below shows the count of students in Mobility. The Y-axis represents countries, and the X-axis represents the count of students.

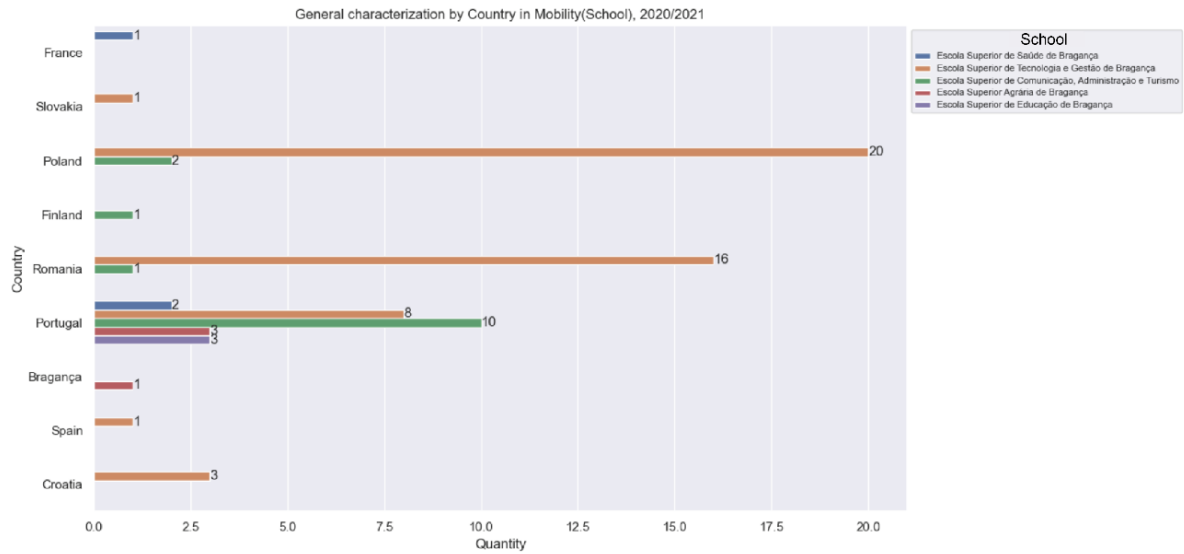

Figure 160: General characterization by Country in Mobility(School), 2020/2021

The bar chart below shows the count of students in Mobility. The Y-axis represents countries, and the X-axis represents the count of students.

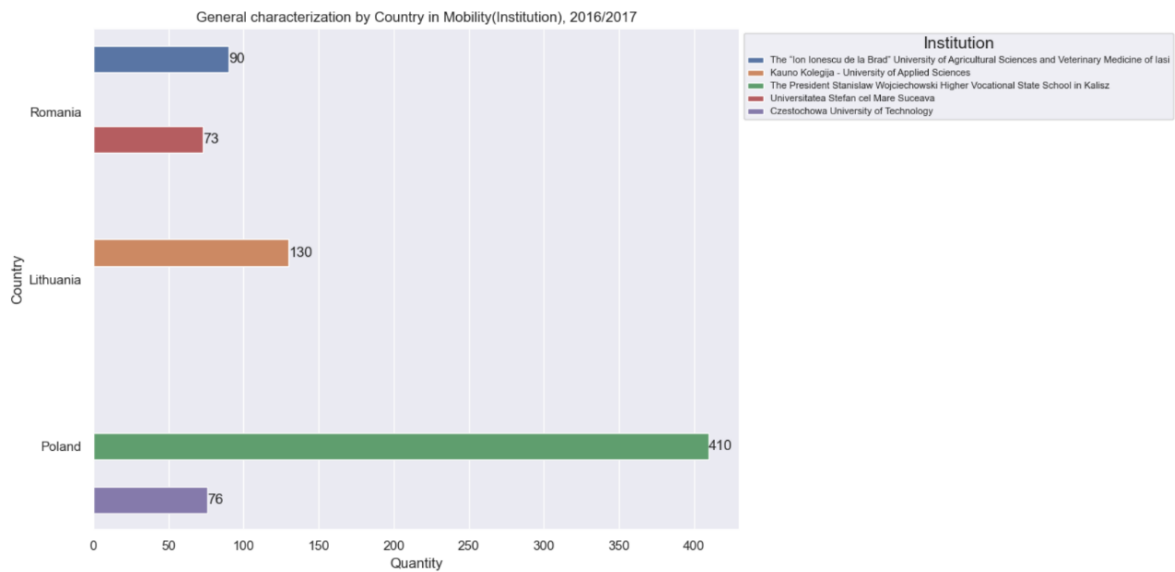

Figure 161: General characterization by Country in Mobility(Institution), 2016/2017

The bar chart below shows the count of students in Mobility. The Y-axis represents countries, and the X-axis represents the count of students.

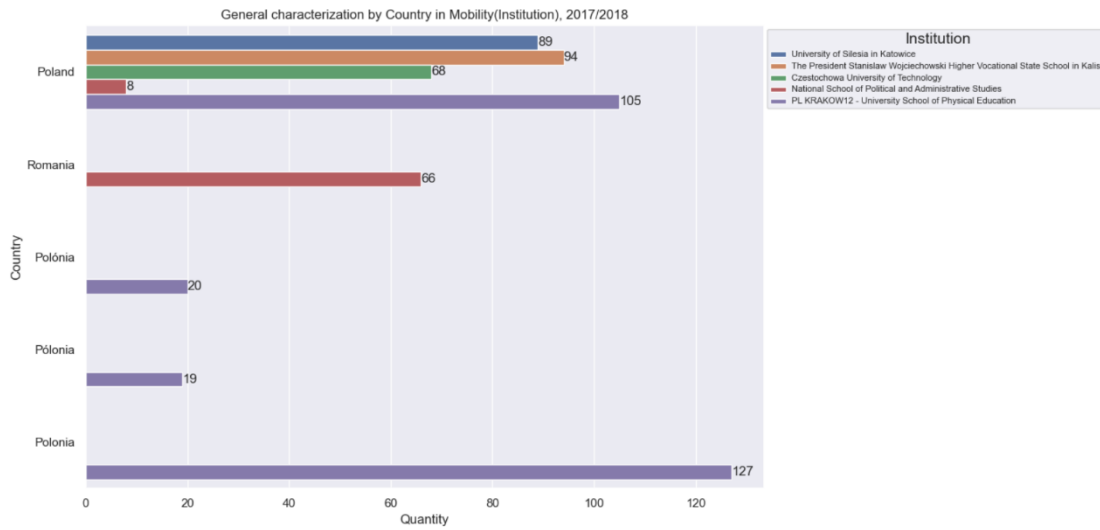

Figure 162: General characterization by Country in Mobility(Institution), 2017/2018

The bar chart below shows the count of students in Mobility. The Y-axis represents countries, and the X-axis represents the count of students.

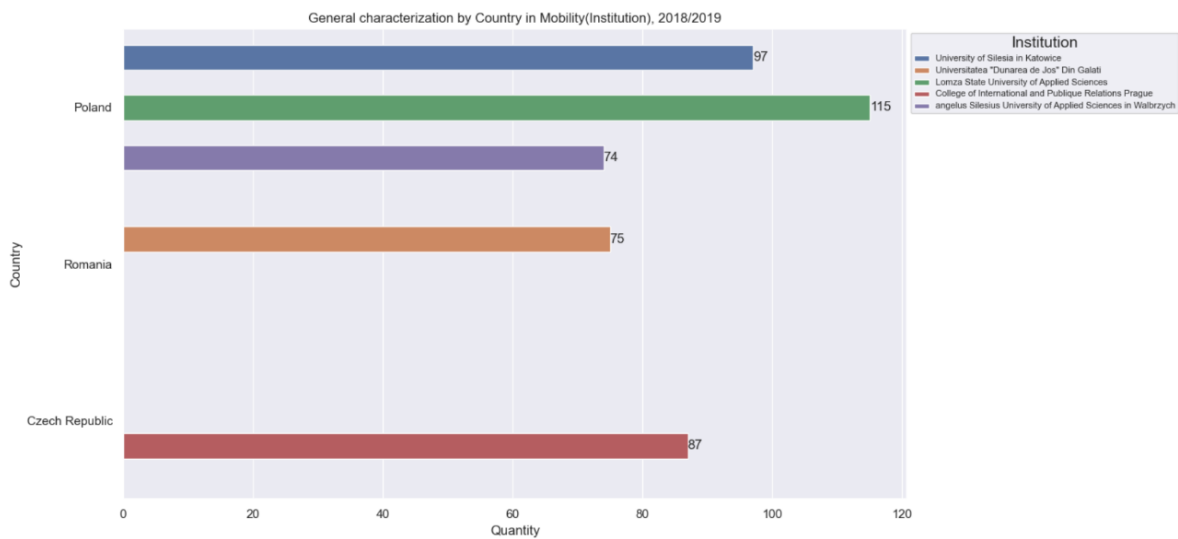

Figure 163: General characterization by Country in Mobility(Institution), 2018/2019

The bar chart below shows the count of students in Mobility. The Y-axis represents countries, and the X-axis represents the count of students.

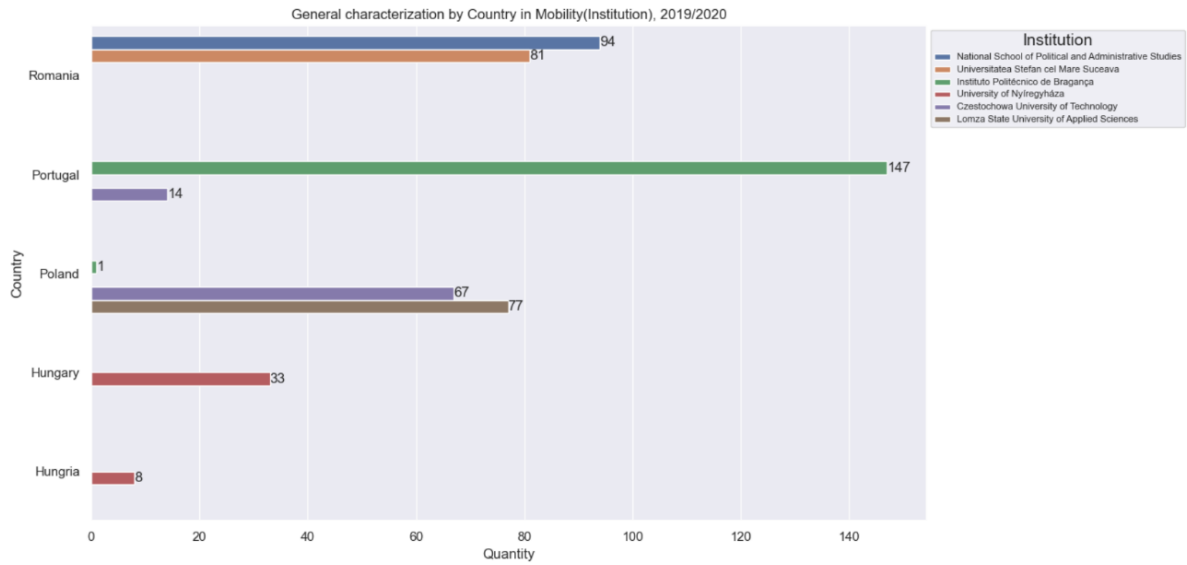

Figure 164: General characterization by Country in Mobility(Institution), 2019/2020

The bar chart below shows the count of students in Mobility. The Y-axis represents countries, and the X-axis represents the count of students.

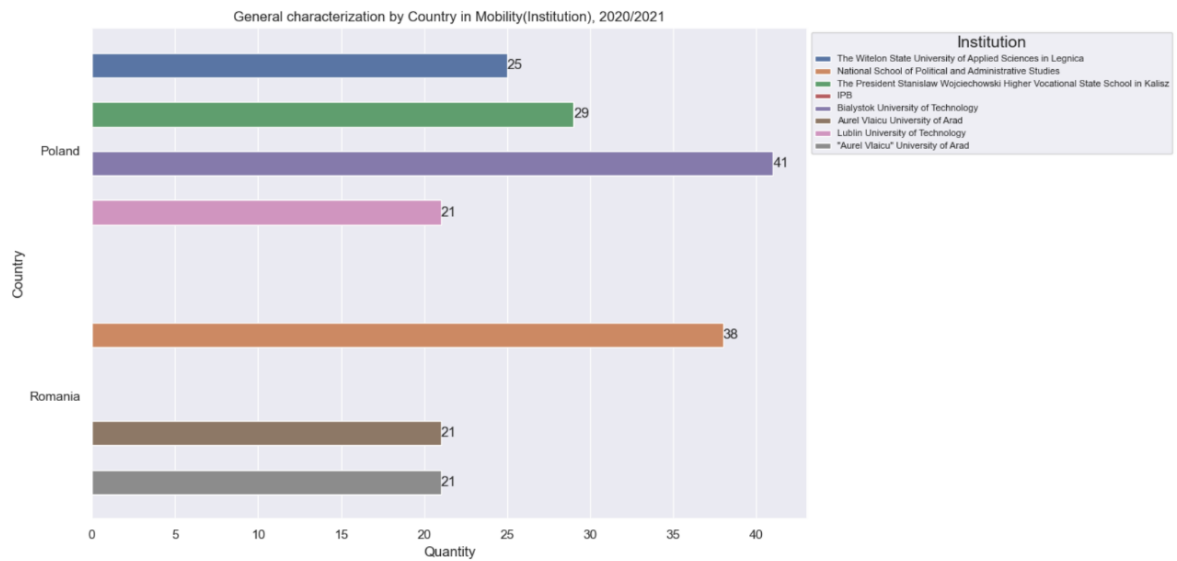

Figure 165: General characterization by Country in Mobility(Institution), 2020/2021

The bar chart below shows the count of students in Mobility. The Y-axis represents countries, and the X-axis represents the count of students.

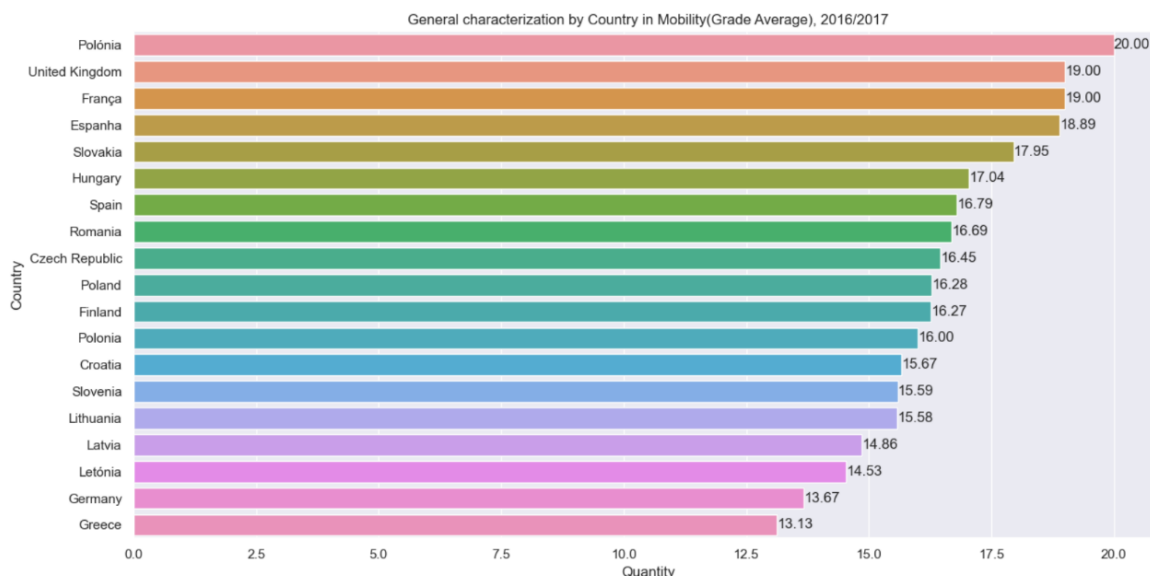

Figure 166: General characterization by Country in Mobility (Average Grade), 2016/2017

The bar chart below shows the average in different countries. The Y-axis represents countries, and the X-axis represents the average value. The highest average score was in Polonia at 20.00, and the lowest average score was in Greece at 13.13.

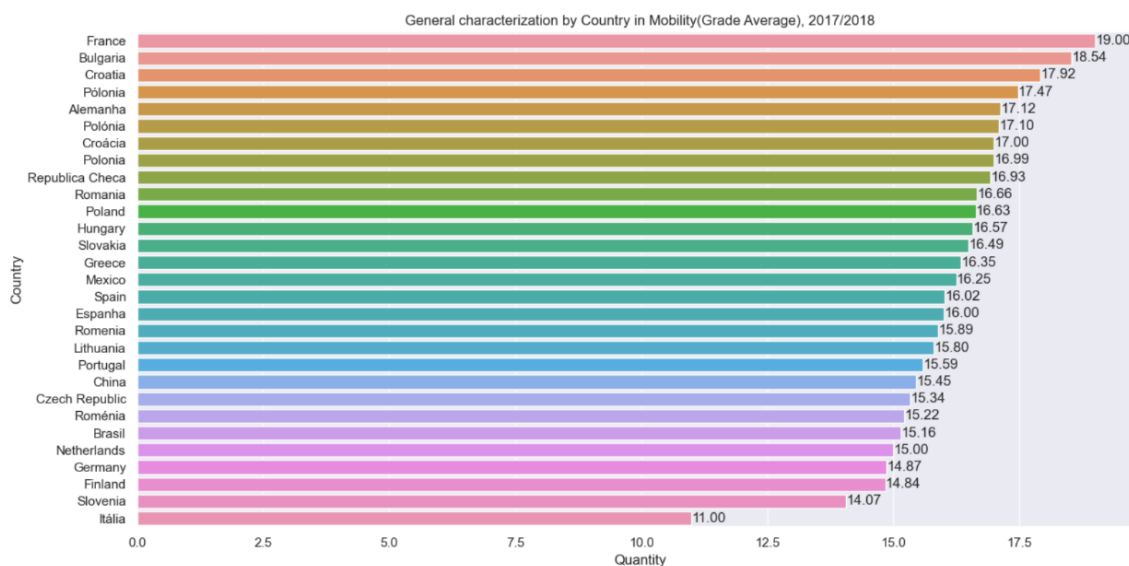

Figure 167: General characterization by Country in Mobility (Average Grade), 2017/2018

The bar chart below shows the average in different countries. The Y-axis represents countries, and the X-axis represents the average value. The highest average score was in France at 19.00, and the lowest average score was in Italia at 11.00

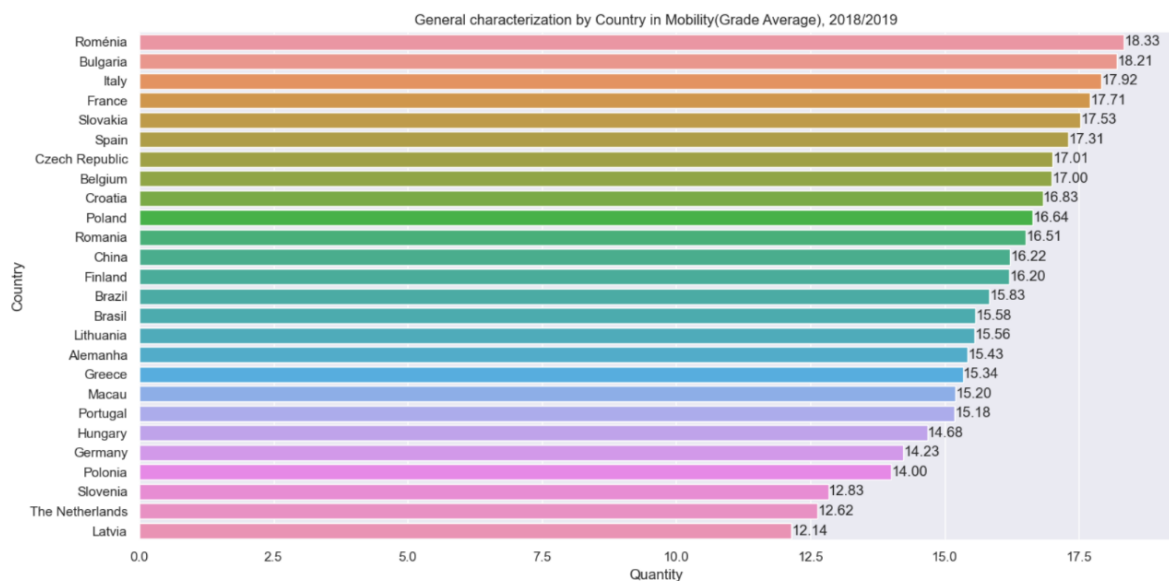

Figure 168: General characterization by Country in Mobility (Average Grade), 2018/2019

The bar chart below shows the average in different countries. The Y-axis represents countries, and the X-axis represents the average value. The highest average score was in Romania at 18.33, and the lowest average score was in Latvia at 12.14.

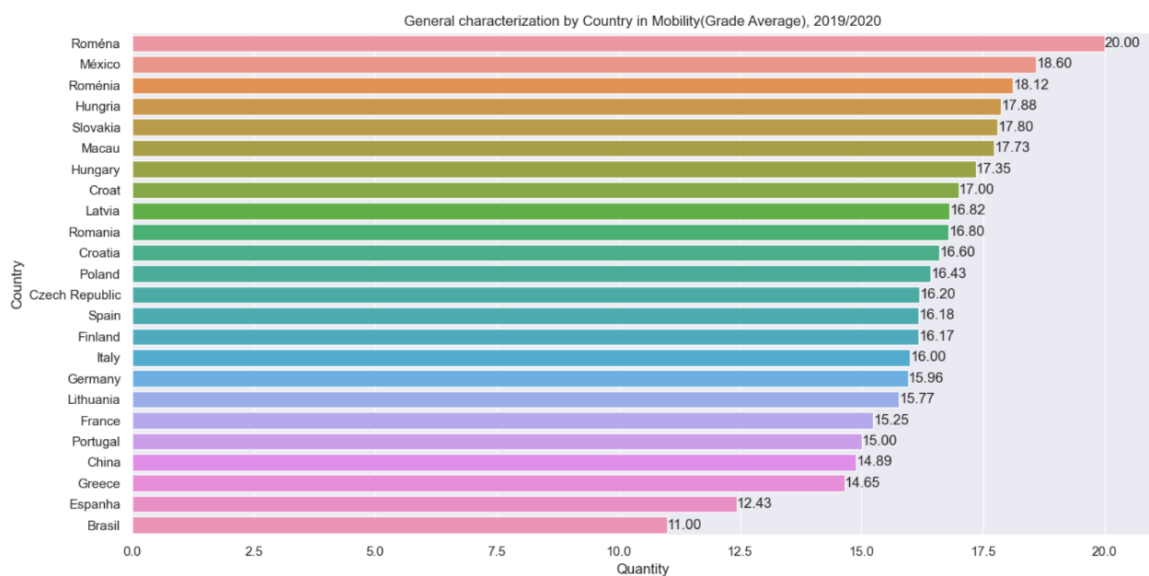

Figure 169: General characterization by Country in Mobility (Average Grade), 2019/2020

The bar chart below shows the average in different countries. The Y-axis represents countries, and the X-axis represents the average value. The highest average score was in Romania at 20.00, and the lowest average score was in Brasil at 11.00.

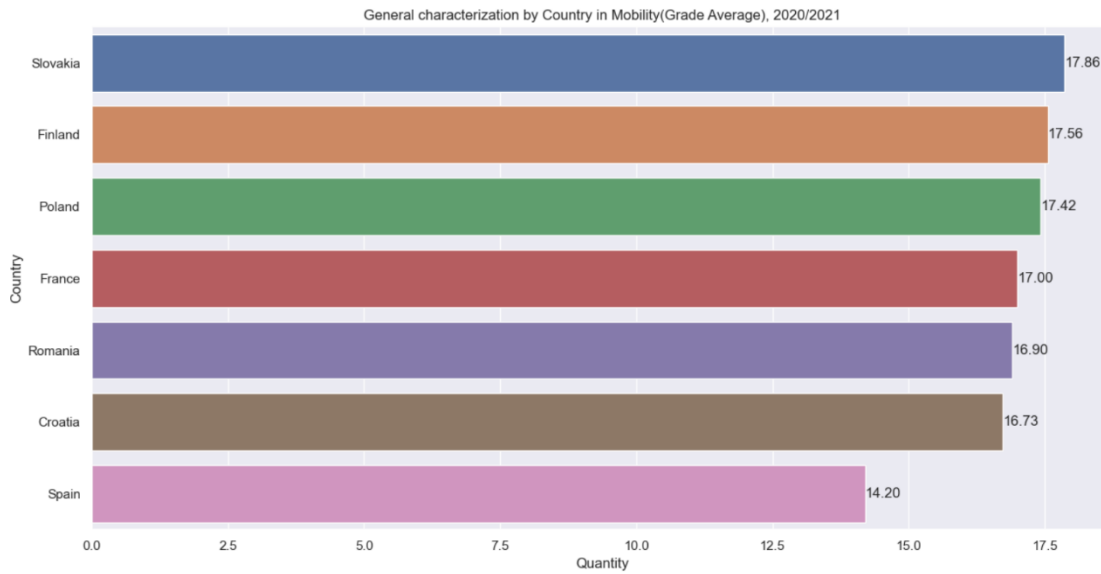

Figure 170: General characterization by Country in Mobility (Average Grade), 2020/2021

The bar chart below shows the average in different countries. The Y-axis represents countries, and the X-axis represents the average value. The highest average score was in Slovakia at 17.86, and the lowest average score was in Spain at 14.20.

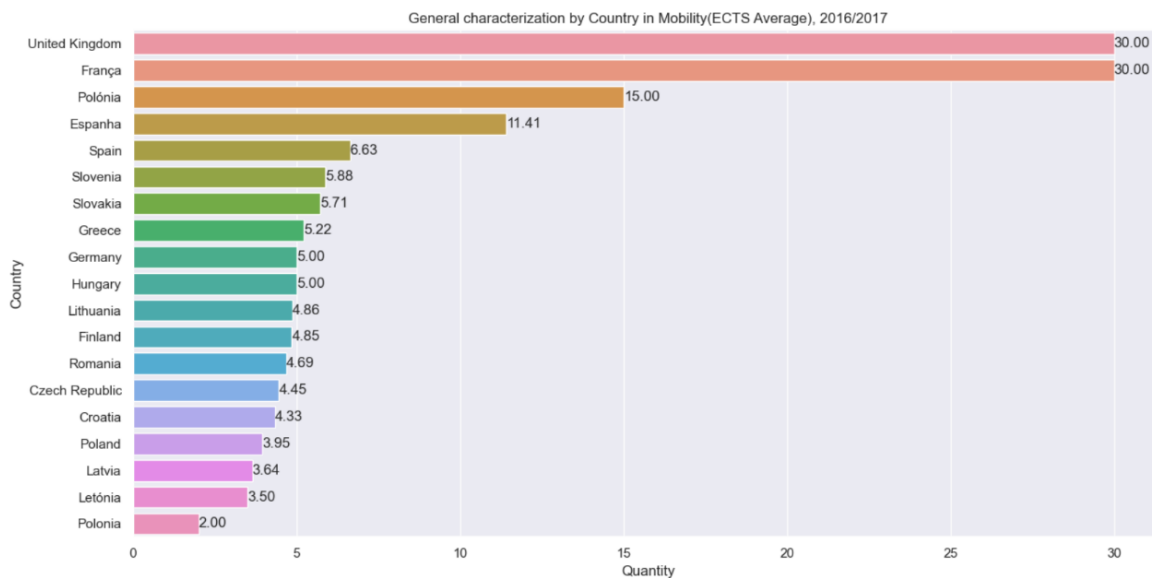

Figure 171: General characterization by Country in Mobility (ECTS Average), 2016/2017

The bar chart below shows the ECTS average in different countries. The Y-axis represents countries, and the X-axis represents the average value. The highest average score was in United Kingdom at 30.00 and in Franca at 30.00, and the lowest average score was in Polonia at 2.00.

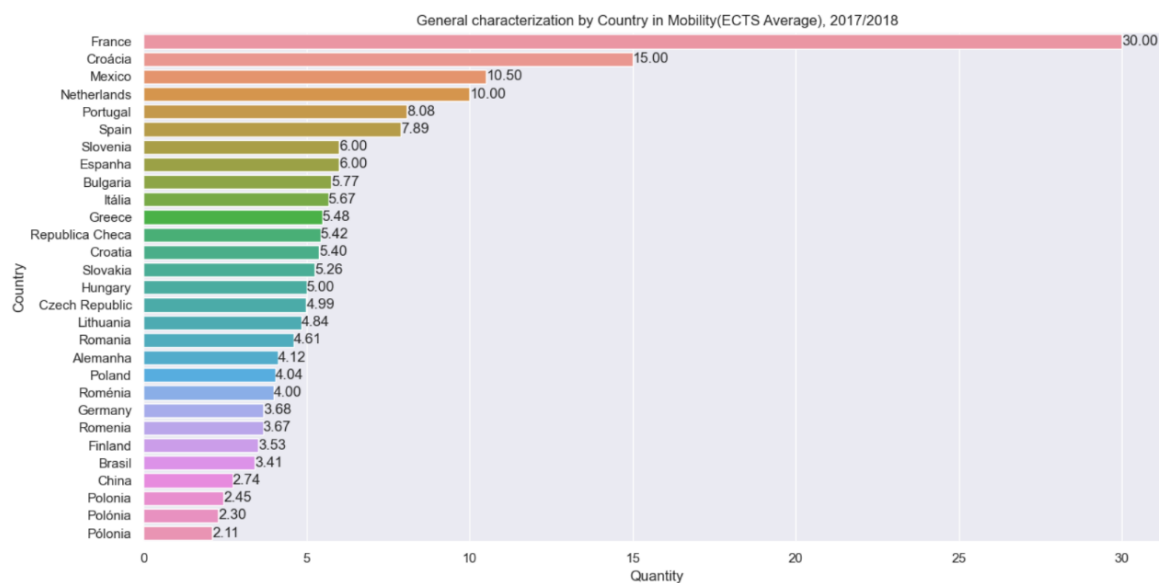

Figure 172: General characterization by Country in Mobility (ECTS Average), 2017/2018

The bar chart below shows the ECTS average in different countries. The Y-axis represents countries, and the X-axis represents the average value. The highest average score was in Francia at 30.00, and the lowest average score was in Polonia at 2.11.

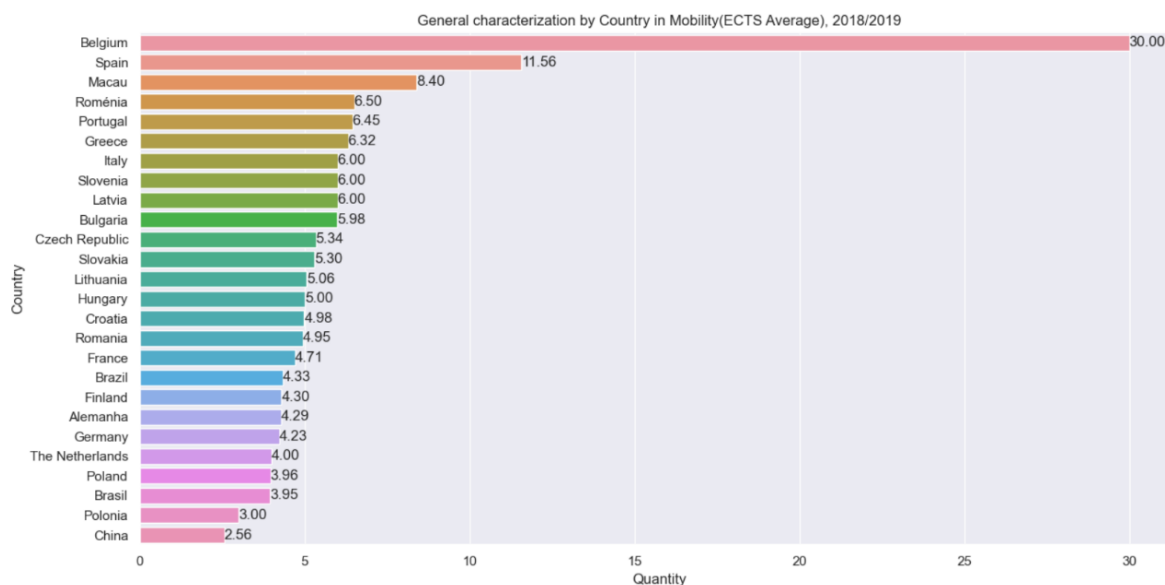

Figure 173: General characterization by Country in Mobility (ECTS Average), 2018/2019

The bar chart below shows the ECTS average in different countries. The Y-axis represents countries, and the X-axis represents the average value. The highest average score was in Belgium at 30.00, and the lowest average score was in China at 2.56.

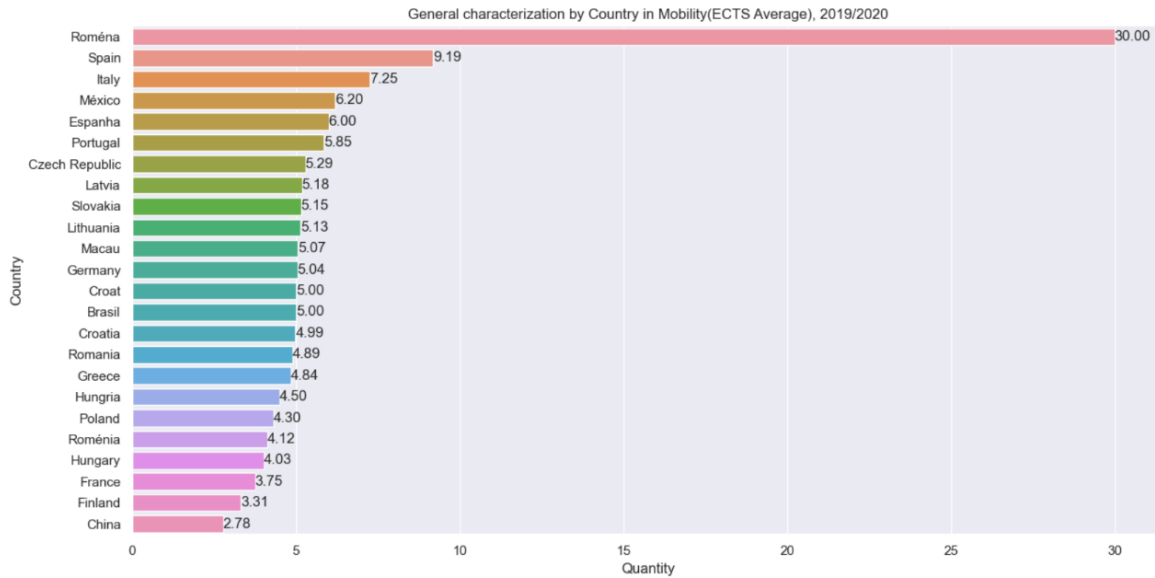

Figure 174: General characterization by Country in Mobility (ECTS Average), 2019/2020

The bar chart below shows the ECTS average in different countries. The Y-axis represents countries, and the X-axis represents the average value. The highest average score was in Romania at 30.00, and the lowest average score was in China at 2.78.

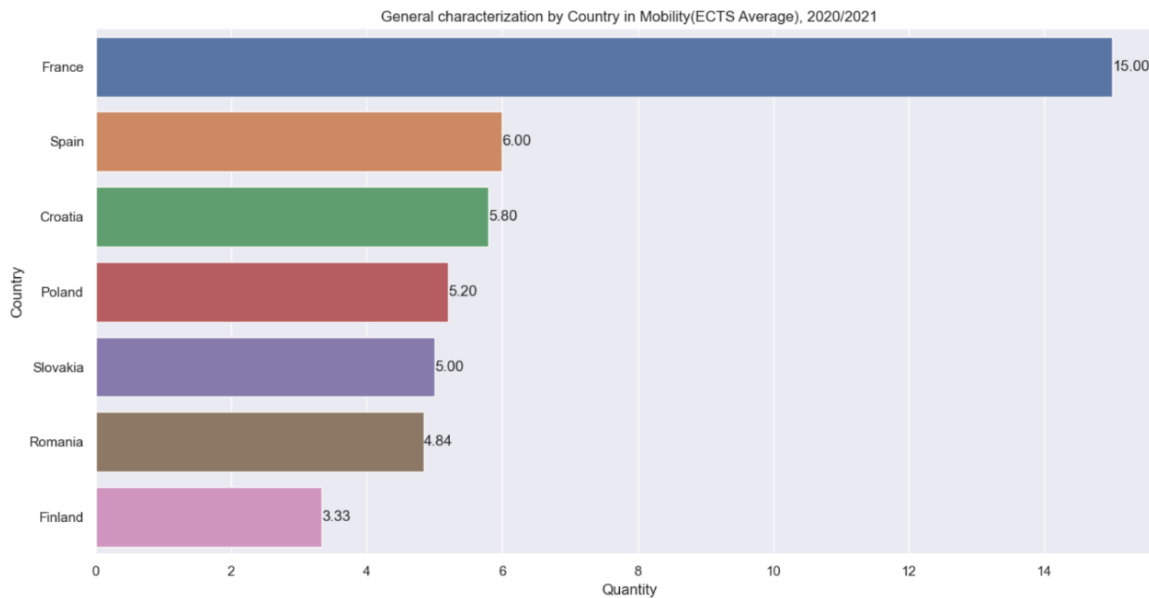

Figure 175: General characterization by Country in Mobility (ECTS Average), 2020/2021

The bar chart below shows the ECTS average in different countries. The Y-axis represents countries, and the X-axis represents the average value. The highest average score was in France at 15.00, and the lowest average score was in Finland at 3.33.

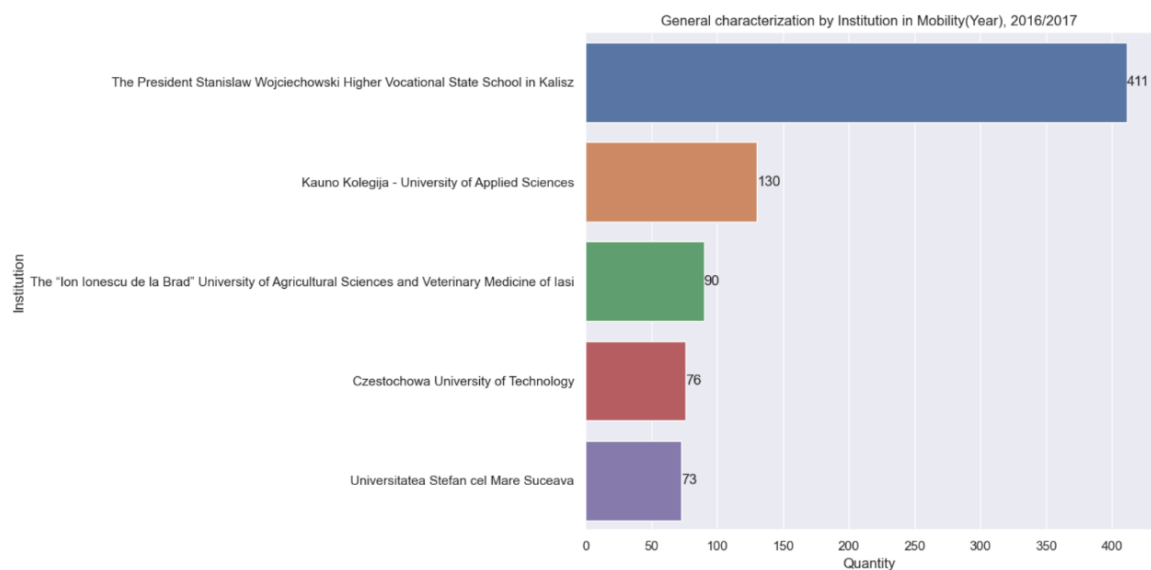

Figure 176: General characterization by Institution in Mobility(Year), 2016/2017

The bar chart below shows the count of students in Mobility. The Y-axis represents institutions, and the X-axis represents the count of students.

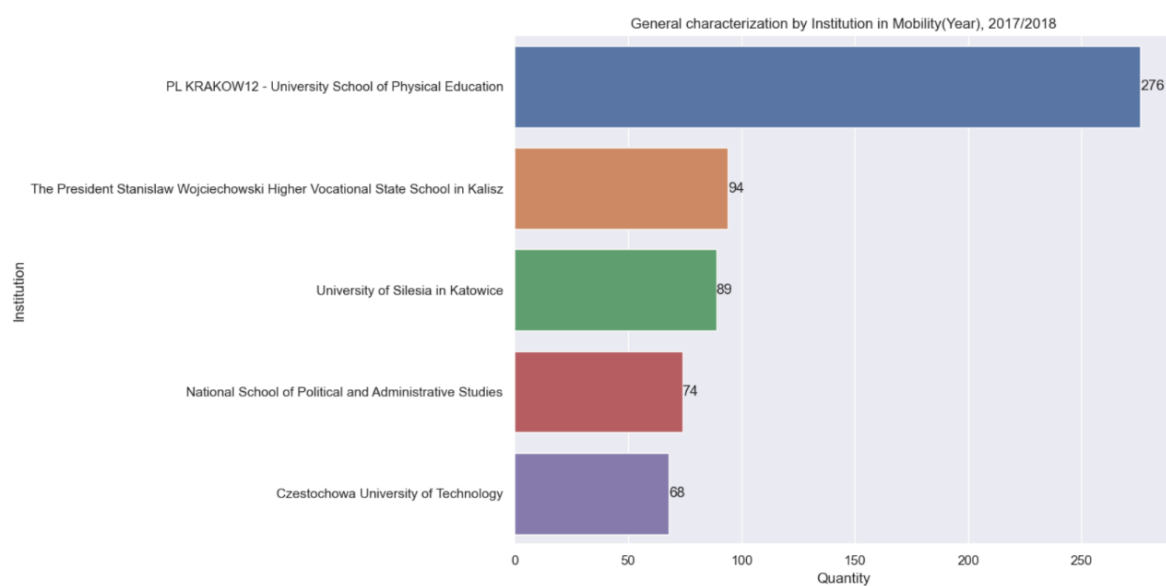

Figure 177: General characterization by Institution in Mobility(Year), 2017/2018

The bar chart below shows the count of students in Mobility. The Y-axis represents institutions, and the X-axis represents the count of students.

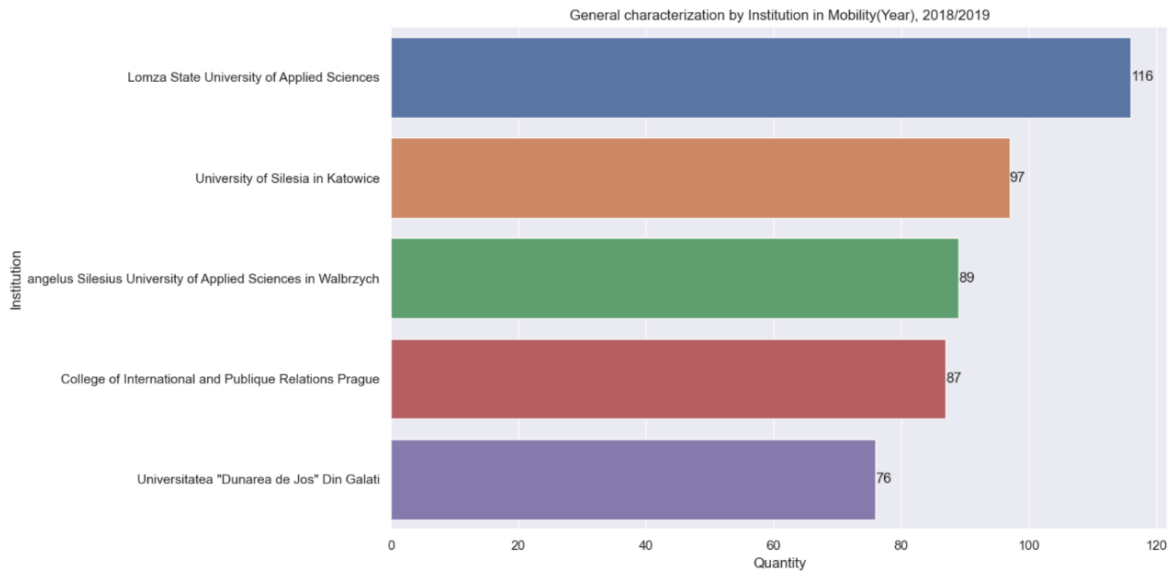

Figure 178: General characterization by Institution in Mobility(Year), 2018/2019

The bar chart below shows the count of students in Mobility. The Y-axis represents institutions, and the X-axis represents the count of students.

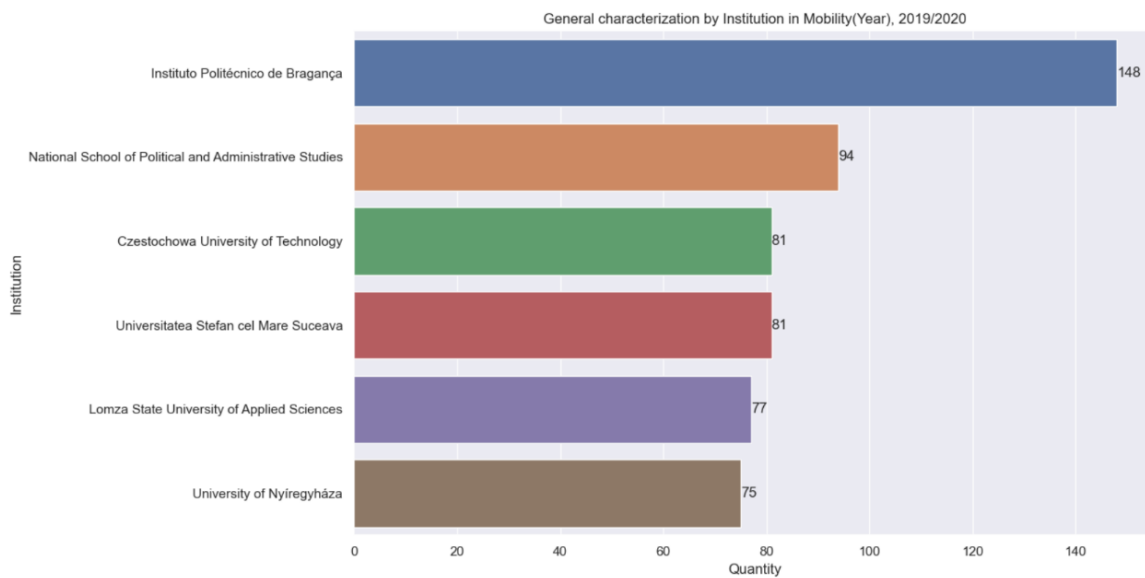

Figure 179: General characterization by Institution in Mobility(Year), 2019/2020

The bar chart below shows the count of students in Mobility. The Y-axis represents institutions, and the X-axis represents the count of students.

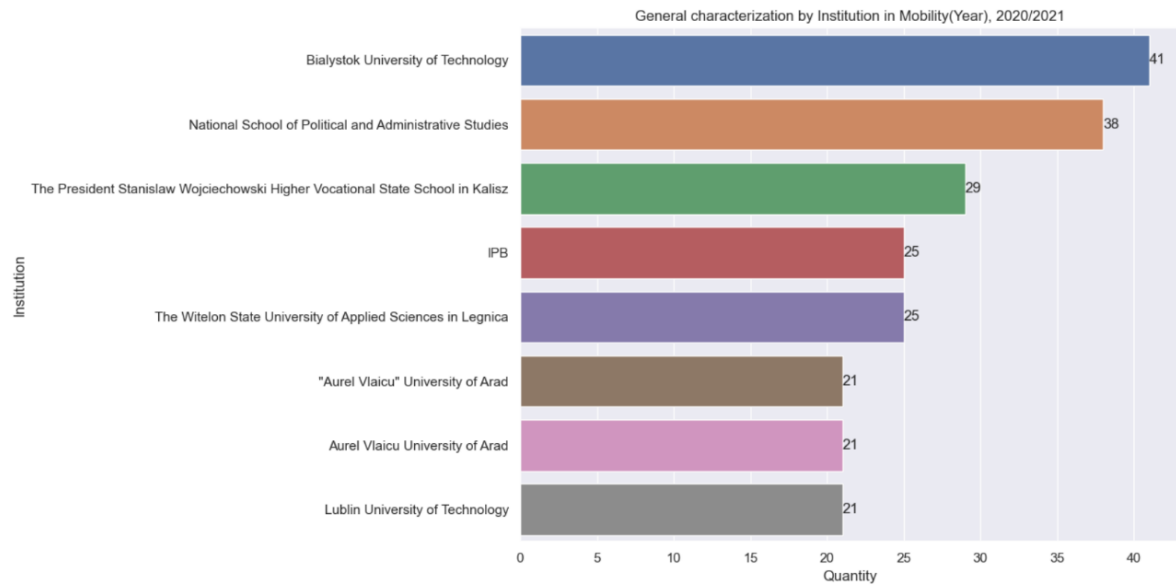

Figure 180: General characterization by Institution in Mobility(Year), 2020/2021

The bar chart below shows the count of students in Mobility. The Y-axis represents institutions, and the X-axis represents the count of students.

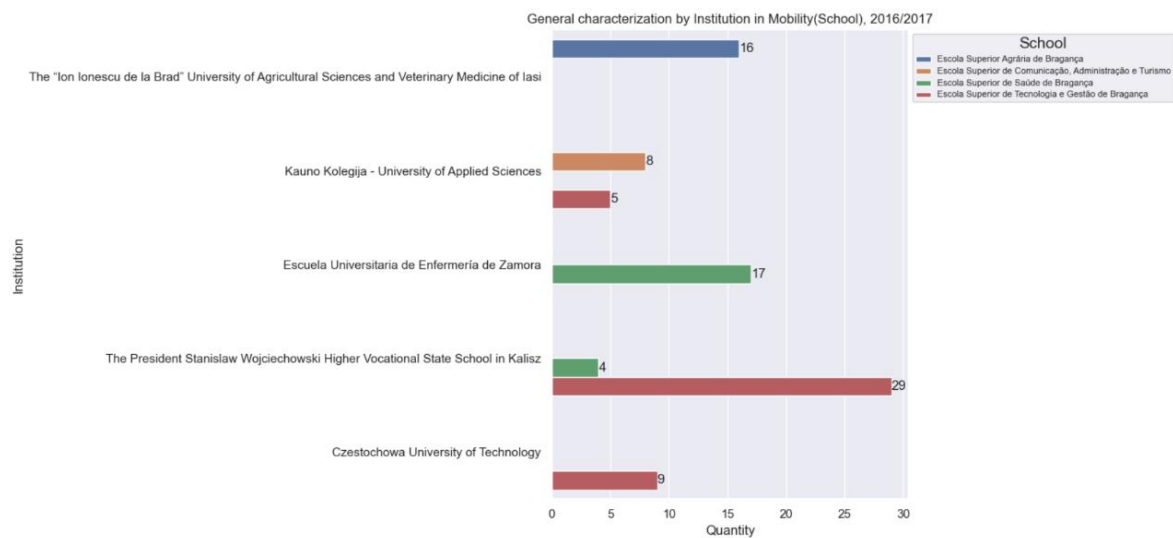

Figure 181: General characterization by Institution in Mobility(School), 2016/2017

The bar chart below shows the count of students in Mobility. The Y-axis represents institutions, and the X-axis represents the count of students.

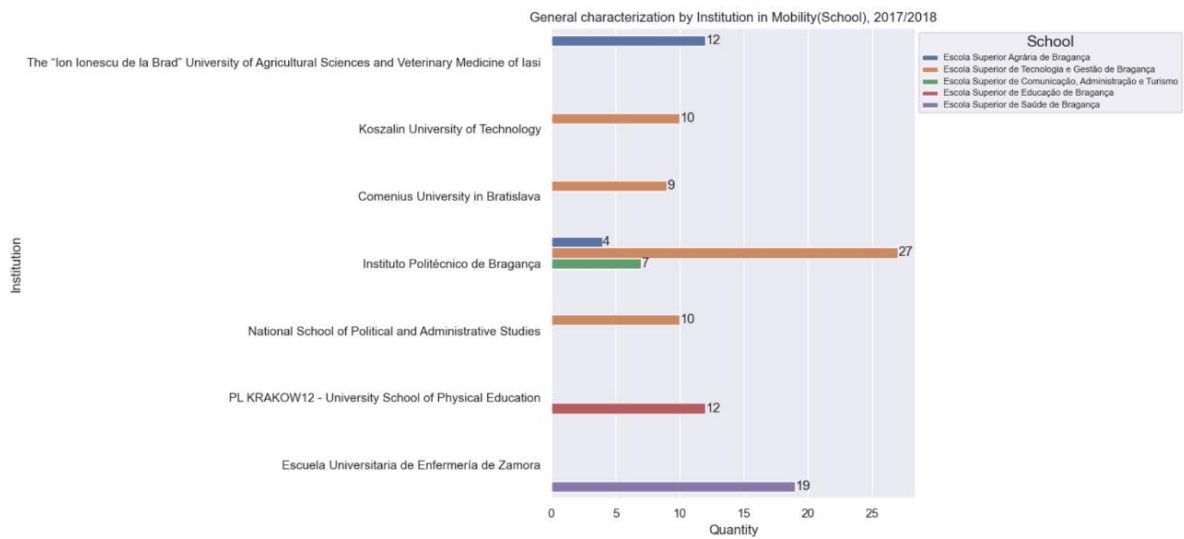

Figure 182: General characterization by Institution in Mobility(School), 2017/2018

The bar chart below shows the count of students in Mobility. The Y-axis represents institutions, and the X-axis represents the count of students.

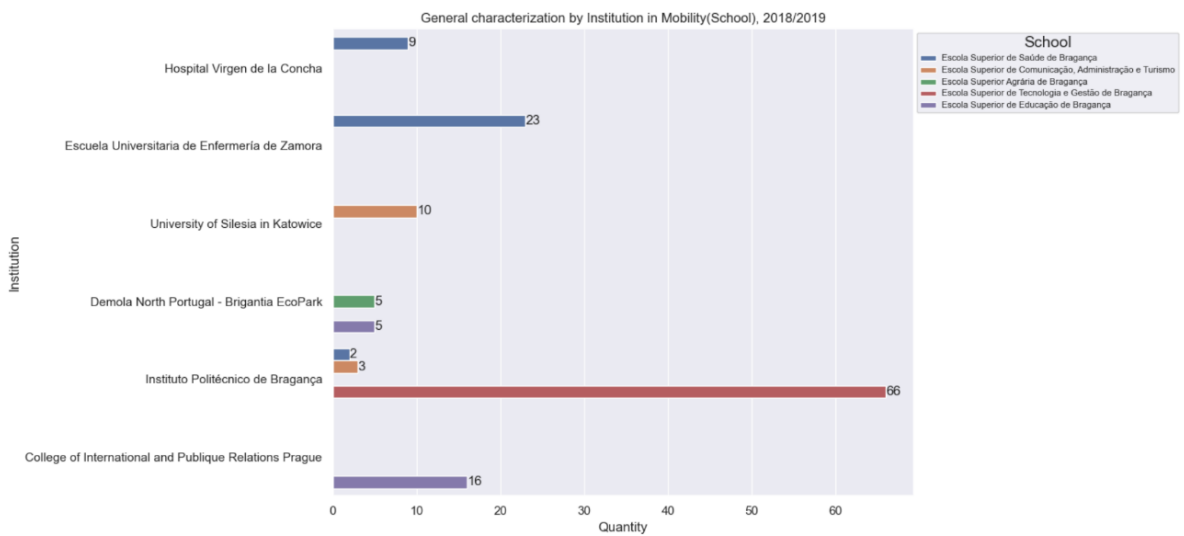

Figure 183: General characterization by Institution in Mobility(School), 2018/2019

The bar chart below shows the count of students in Mobility. The Y-axis represents institutions, and the X-axis represents the count of students.

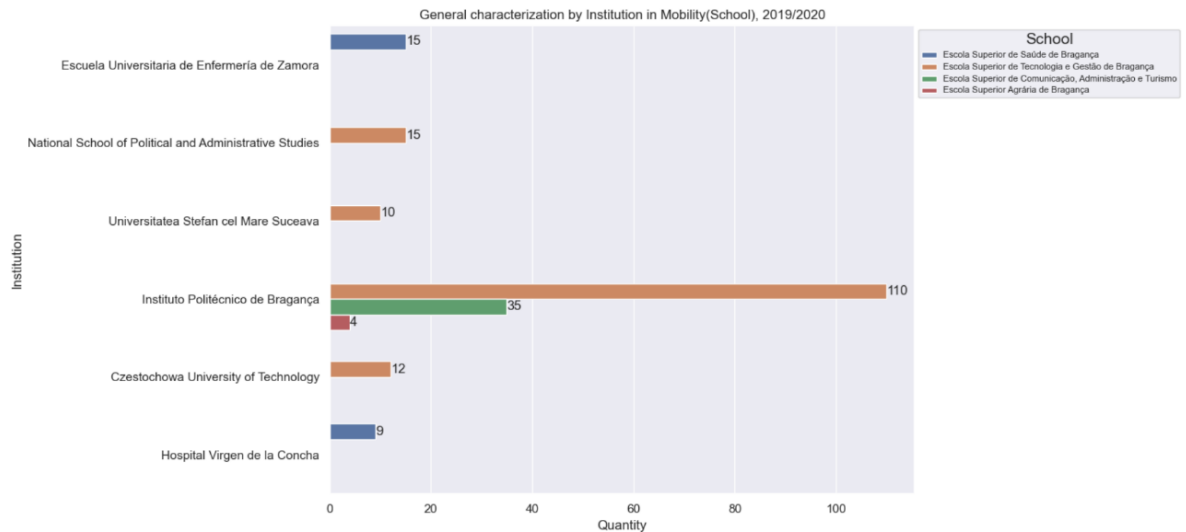

Figure 184: General characterization by Institution in Mobility(School), 2019/2020

The bar chart below shows the count of students in Mobility. The Y-axis represents institutions, and the X-axis represents the count of students.

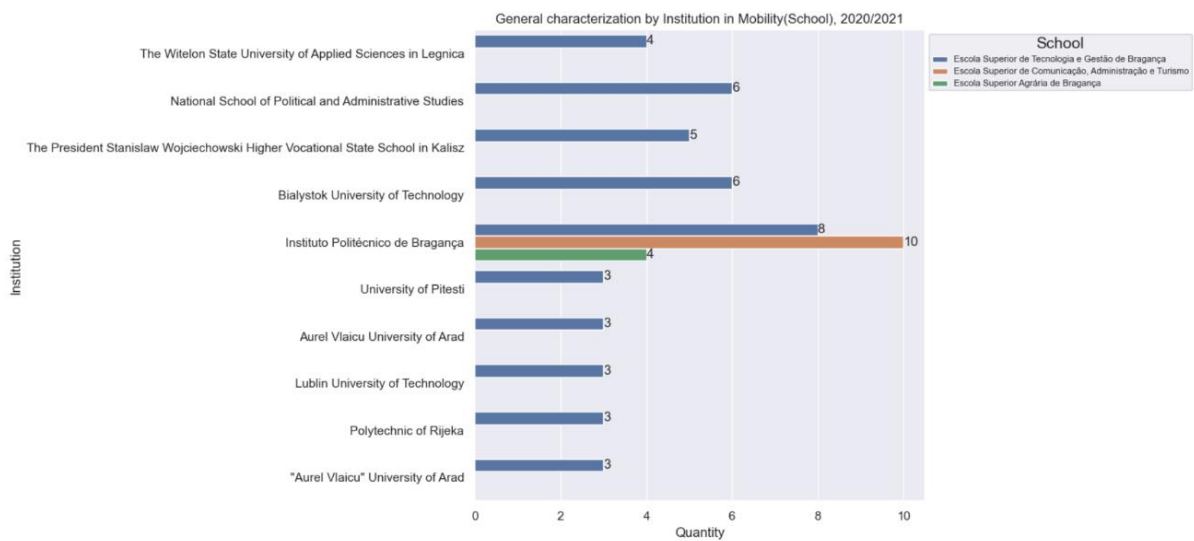

Figure 185: General characterization by Institution in Mobility(School), 2020/2021

The bar chart below shows the count of students in Mobility. The Y-axis represents institutions, and the X-axis represents the count of students.

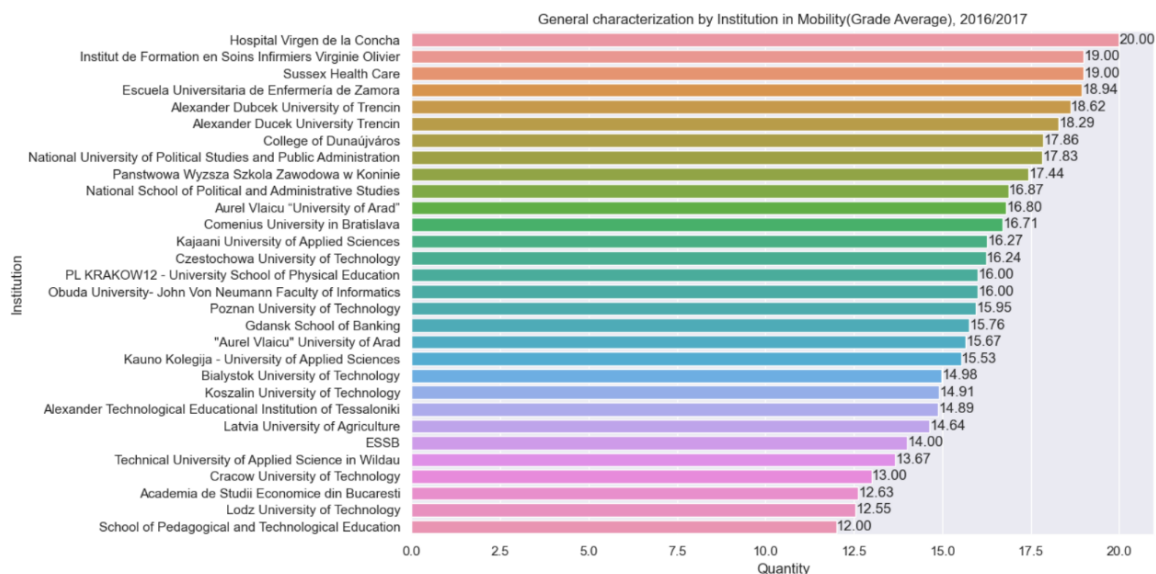

Figure 186: General characterization by Institution in Mobility (Average Grade), 2016/2017, (1st part)

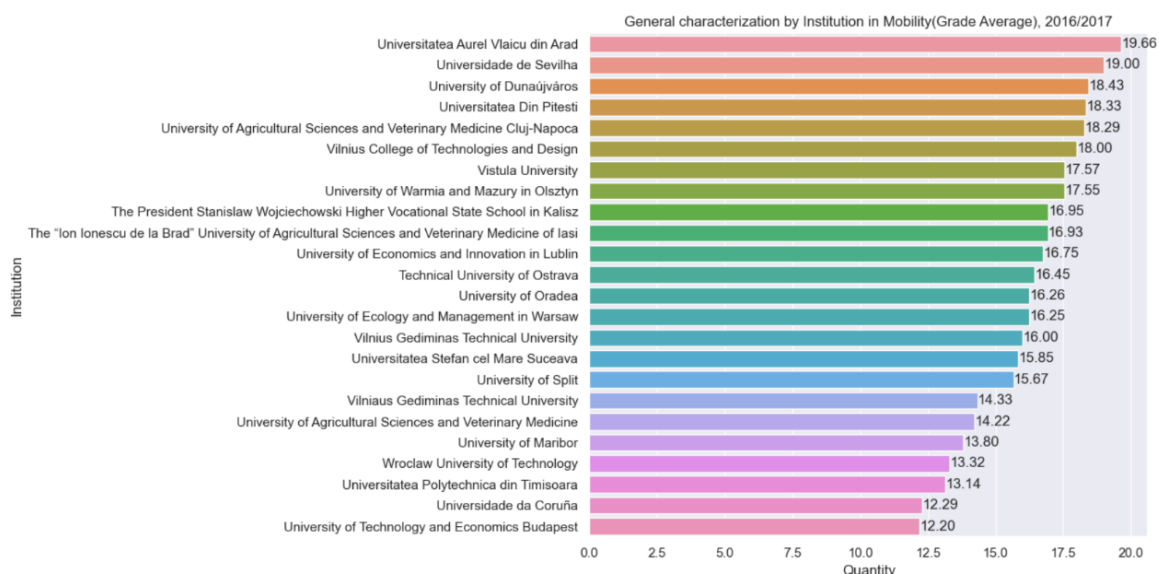

Figure 187: General characterization by Institution in Mobility (Average Grade), 2016/2017 (2nd part)

The bar chart below shows the average in different institutions. The Y-axis represents institutions, and the X-axis represents the average value. The highest average score was in Universitatea Aurel Vlaicu din Arad at 20.00, and the lowest average score was in School of Pedagogical and Technological Education at 12.00.

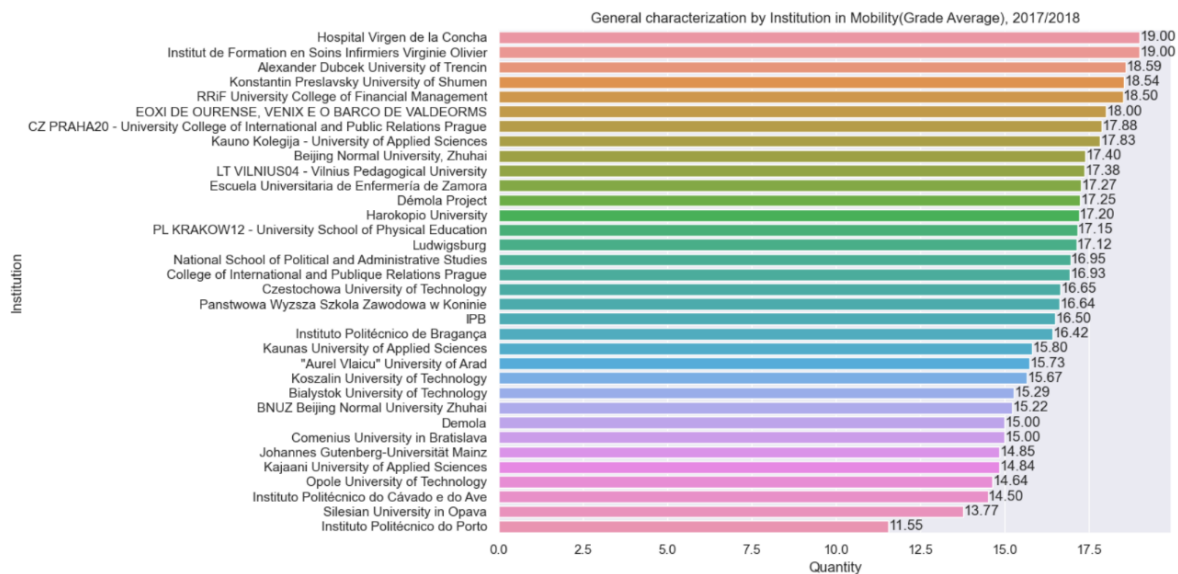

Figure 188: General characterization by Institution in Mobility (Average Grade), 2017/2018, (1st part)

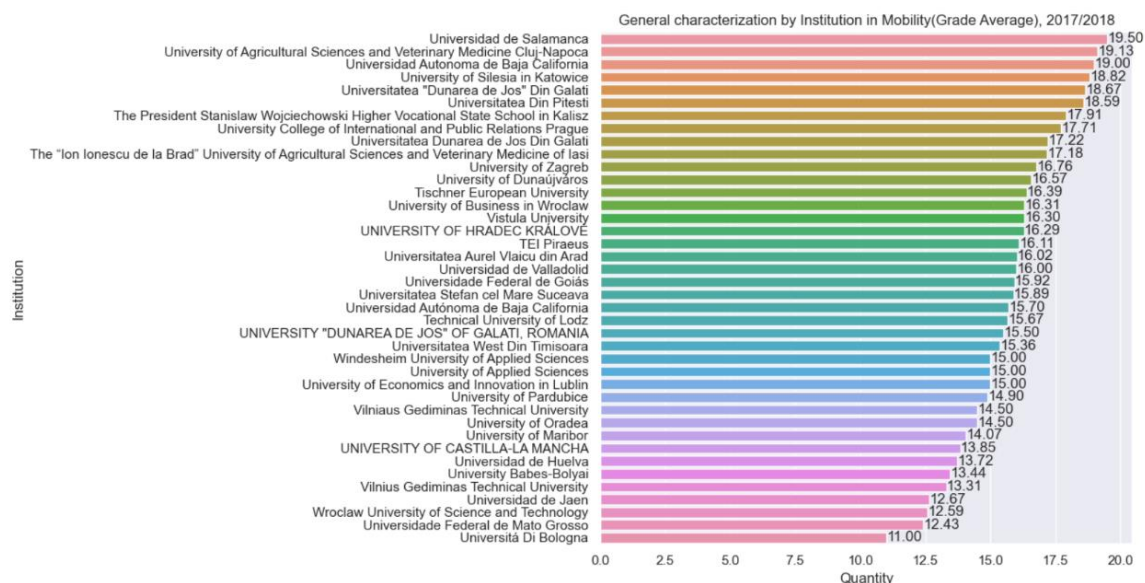

Figure 189: General characterization by Institution in Mobility (Average Grade), 2017/2018 (2nd part)

The bar chart below shows the average in different institutions. The Y-axis represents institutions, and the X-axis represents the average value. The highest average score was in Universidad de Salamanca at 19.50, and the lowest average score was in Università Di Bologna at 11.00.

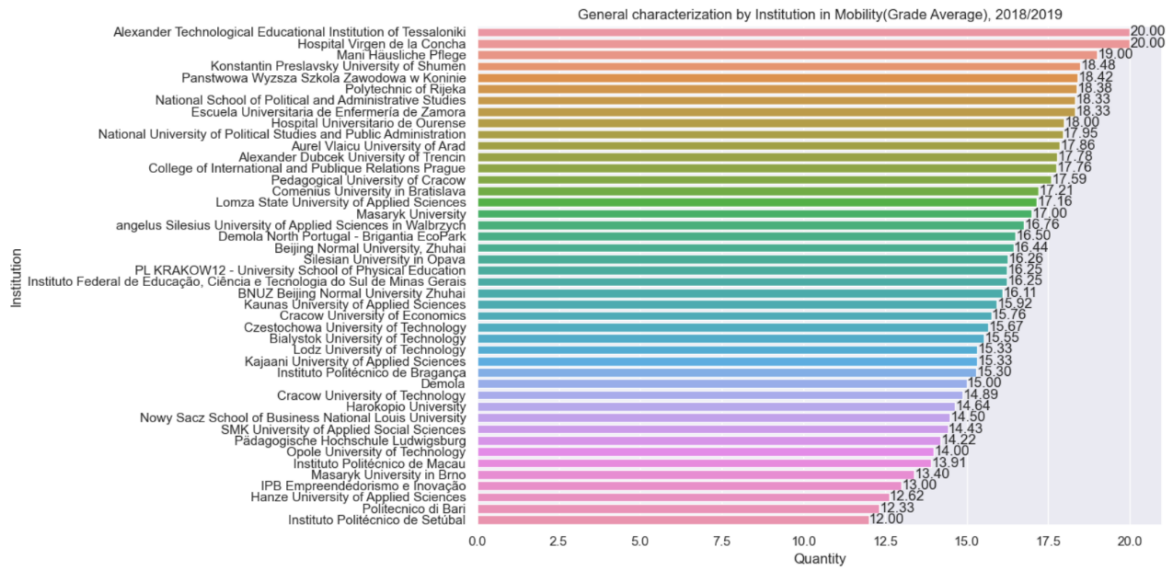

Figure 190: General characterization by Institution in Mobility (Average Grade), 2018/2019, (1st part)

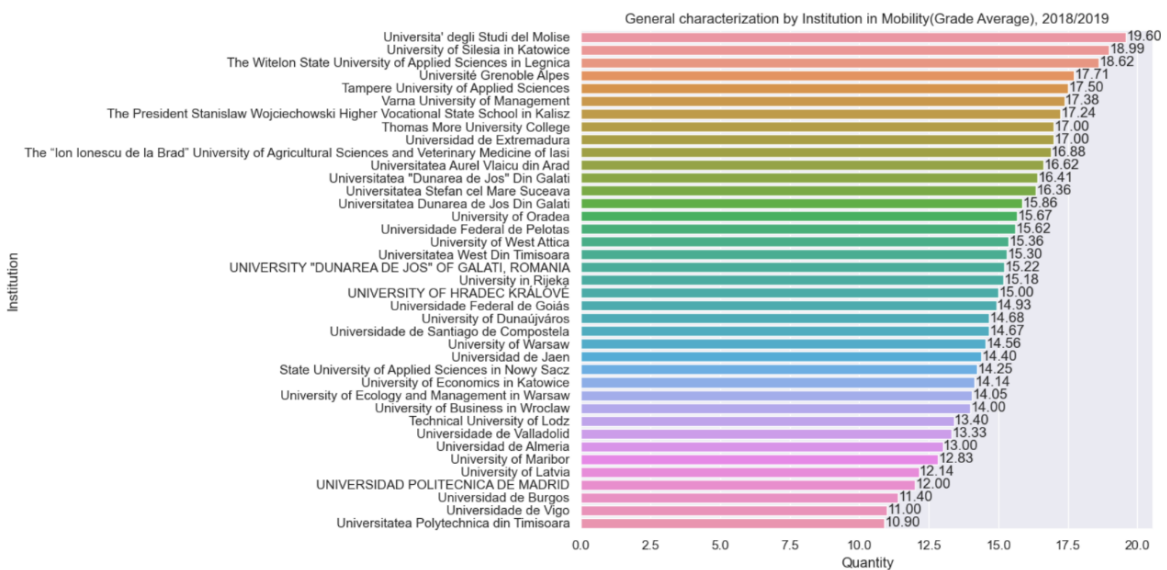

Figure 191: General characterization by Institution in Mobility (Average Grade), 2017/2018 (2nd part)

The bar chart below shows the average in different institutions. The Y-axis represents institutions, and the X-axis represents the average value. The highest average score was in Alexander Technological Educational Institution of Tesseloniki at 20.00 and in Hospital Virgen de la Concha at 20.00, and the lowest average score was in Universitatea Polytechnica din Timisoara at 10.90.

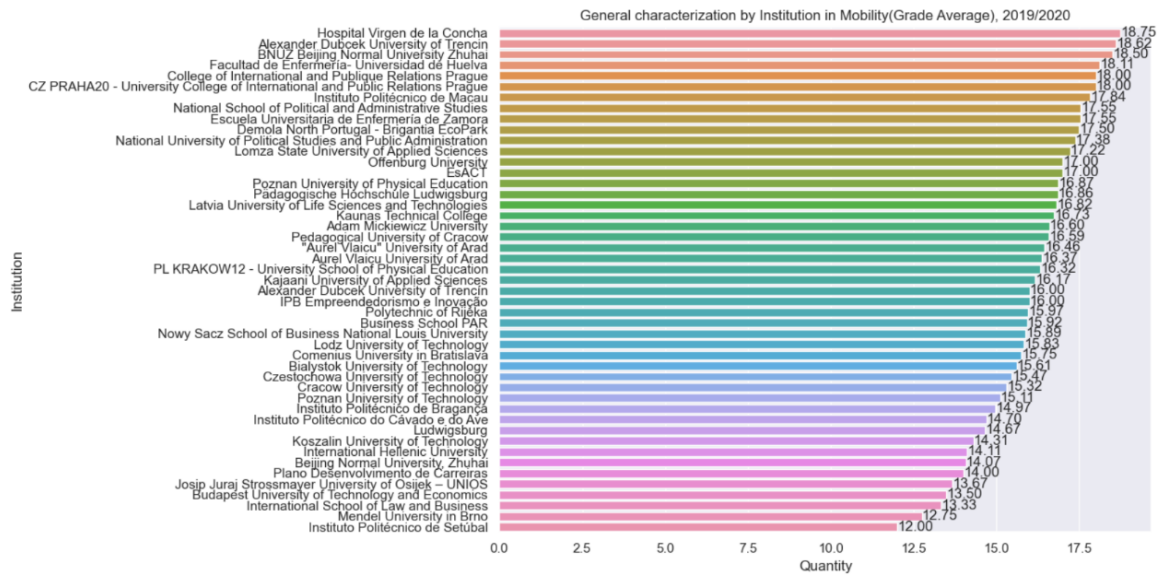

Figure 192: General characterization by Institution in Mobility (Average Grade), 2019/2020, (1st part)

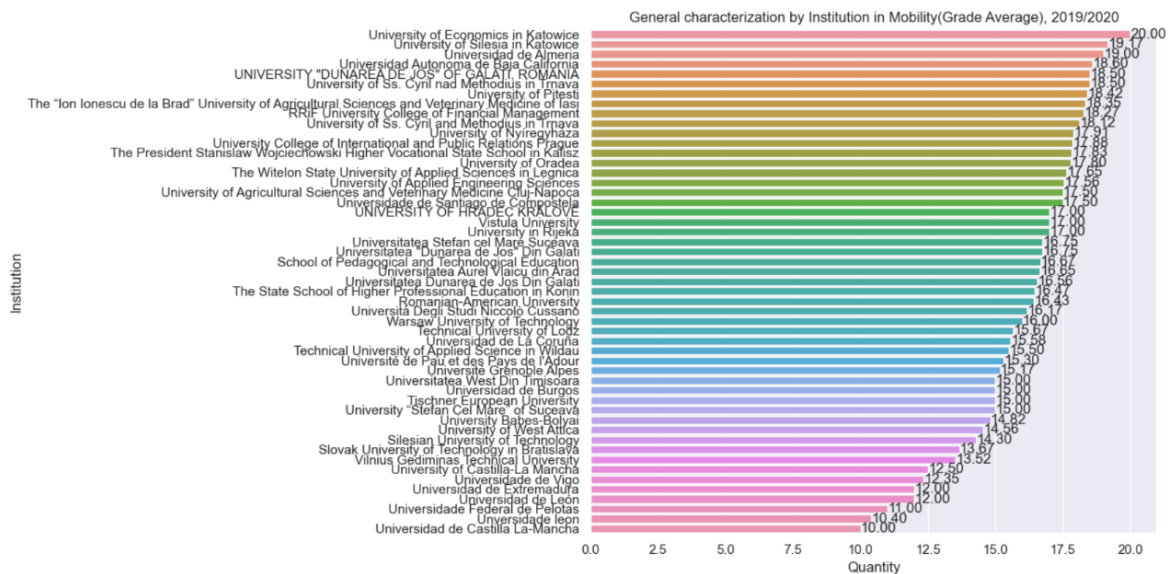

Figure 193: General characterization by Institution in Mobility (Average Grade), 2019/2020 (2nd part)

The bar chart below shows the average in different institutions. The Y-axis represents institutions, and the X-axis represents the average value. The highest average score was in University of Silesia in Katowice at 20.00, and the lowest average score was in Universidad de Castilla La-Mancha at 10.00.

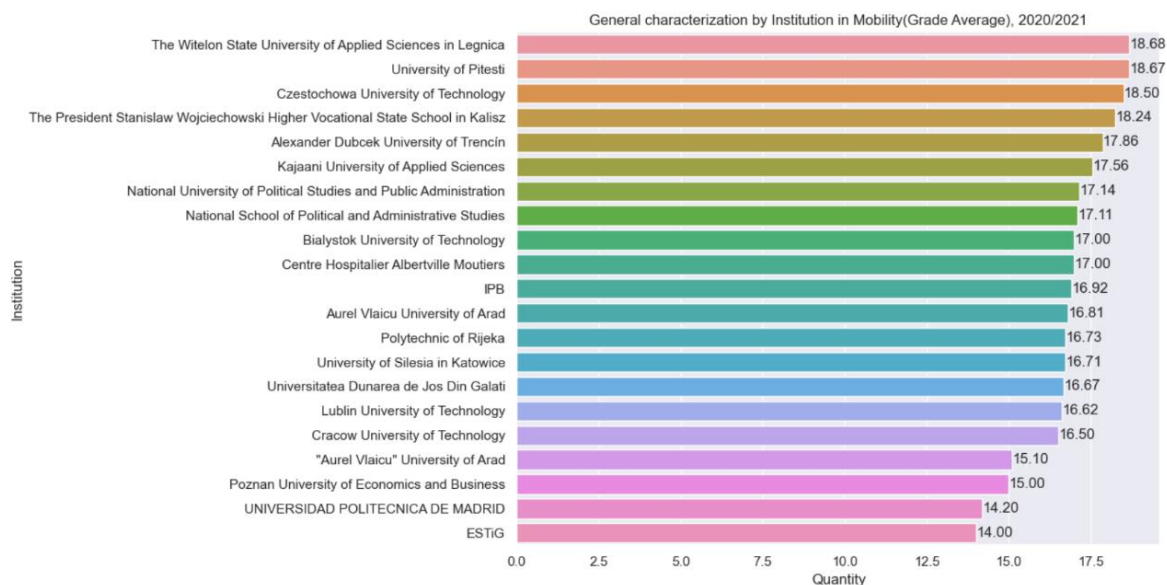

Figure 194: General characterization by Institution in Mobility (Average Grade), 2020/2021

The bar chart below shows the average in different institutions. The Y-axis represents institutions, and the X-axis represents the average value. The highest average score was in The Witelon State University of Applied Sciences in Legnica at 18.68, and the lowest average score was in ESTiG at 14.00.

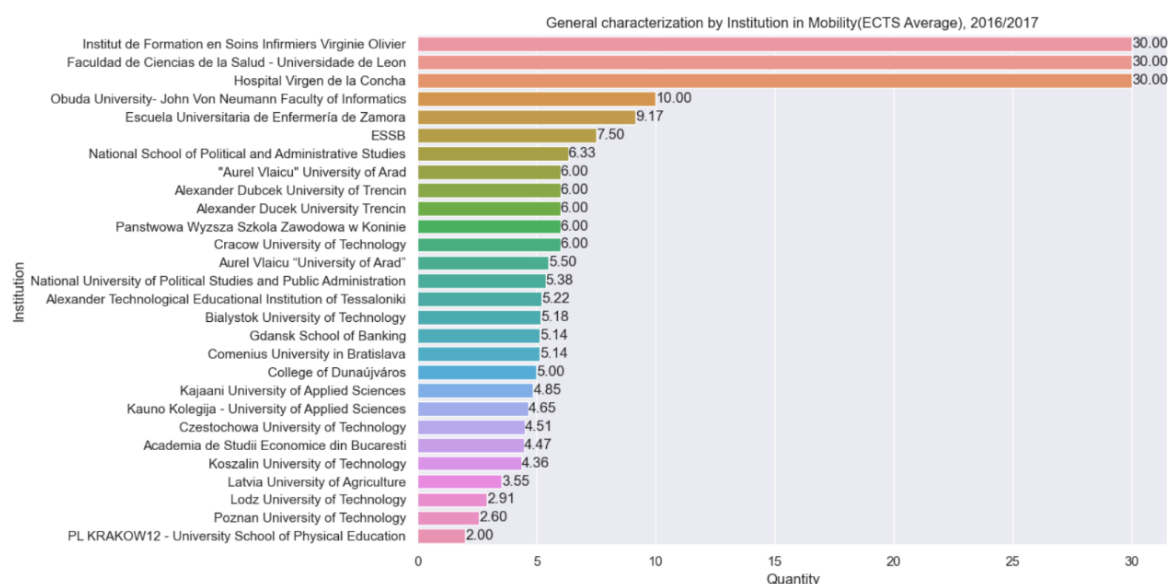

Figure 195: General characterization by Institution in Mobility (Average ECTS), 2016/2017, (1st part)

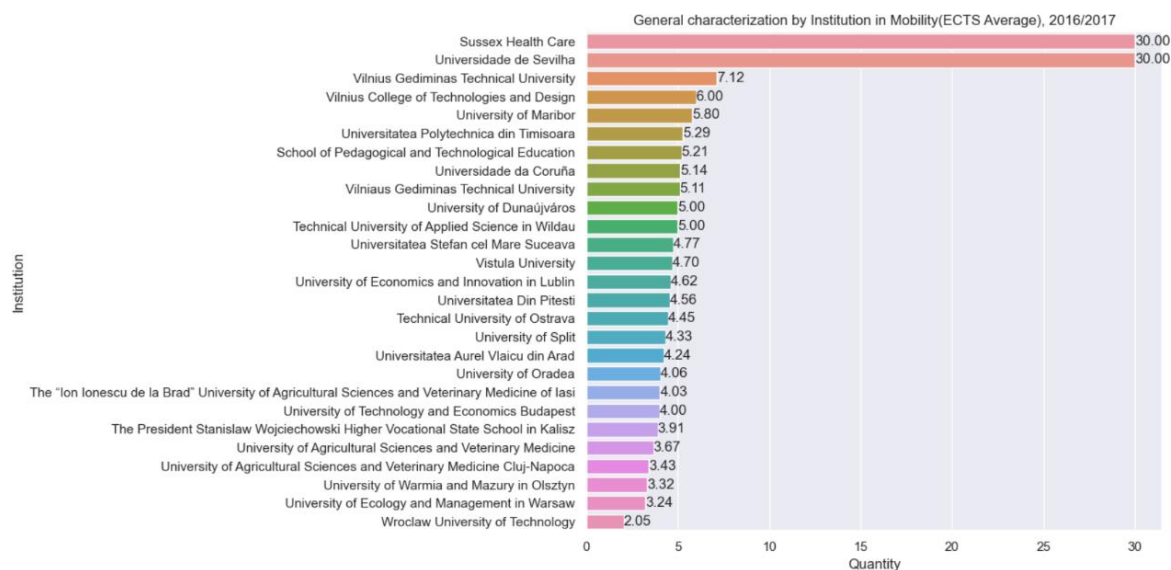

Figure 196: General characterization by Institution in Mobility (Average ECTS), 2016/2017, (2nd part)

The bar chart below shows the average in different institutions. The Y-axis represents institutions, and the X-axis represents the average value. The highest ECTS score was in Institut de Formation en Soins Infirmiers Virginie Olivier at 30.00, Facultad de Ciencias de la Salud - Universidade de Leon at 30.00, Hospital Virgen de la Concha at 30.00, Sussex Health Care at 30.00, Universidade de Sevilha at 30.00; the ECTS average score was in Wrocław University of Technology at 2.05.

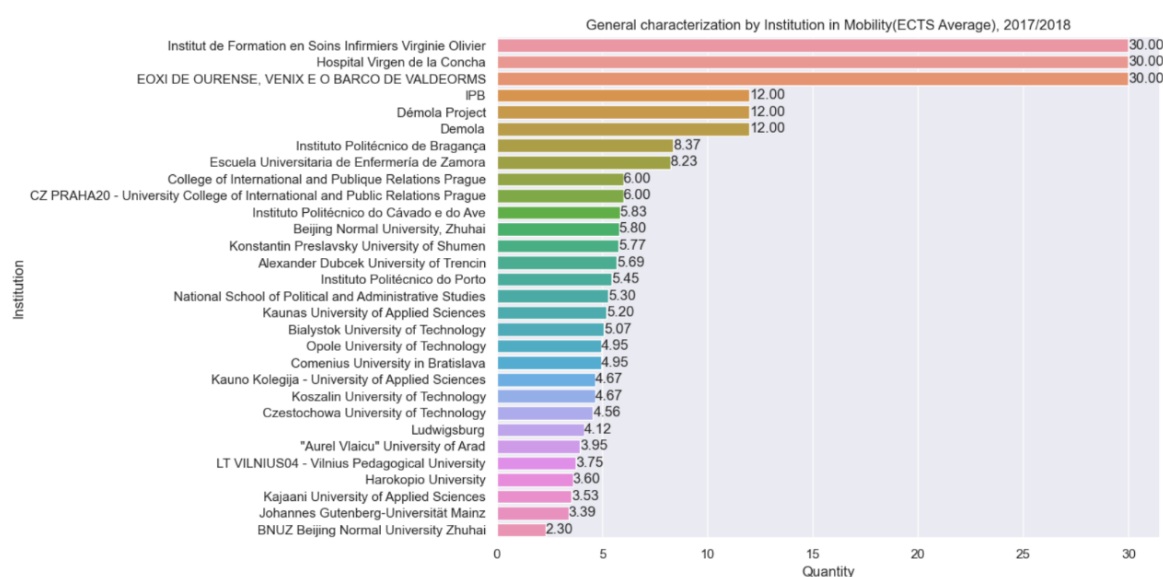

Figure 197: General characterization by Institution in Mobility (Average ECTS), 2017/2018, (1st part)

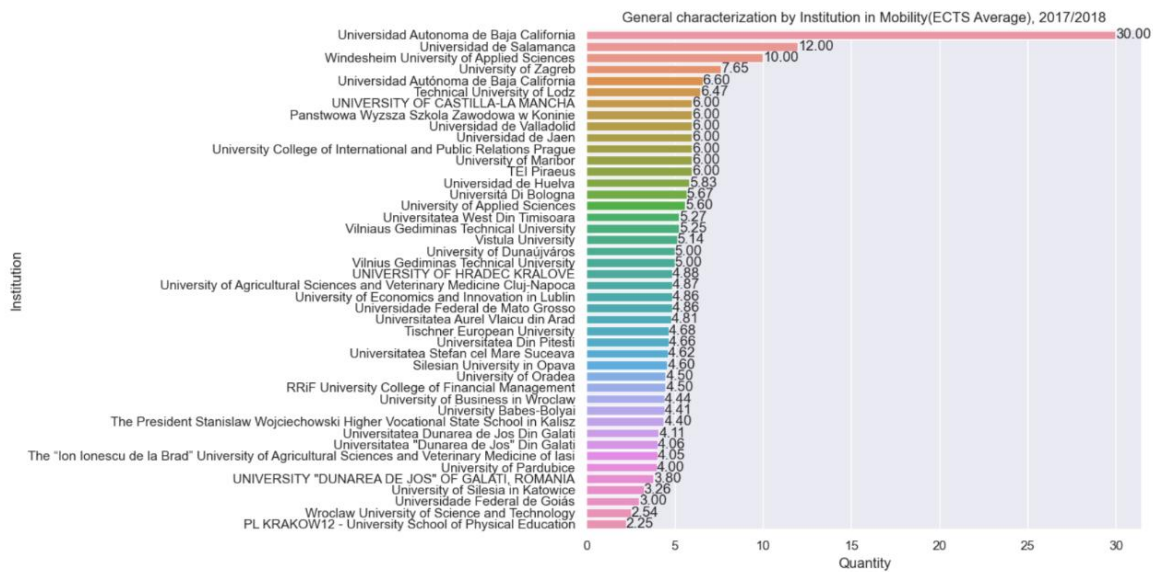

Figure 198: General characterization by Institution in Mobility (Average ECTS), 2017/2018, (2nd part)

The bar chart below shows the average in different institutions. The Y-axis represents institutions, and the X-axis represents the average value. The highest ECTS score was in Institut de Formation en Soins Infirmiers Virginie Olivier at 30.00, EOXI DE OURENSE, VENIX E O BARCO DE VALDEORMS at 30.00, Universidad Autonoma de Baja California at 30.00, Hospital Virgen de la Concha at 30.00; the ECTS average score was in PL KRAKOW12 - University School of Physical Education at 2.25.

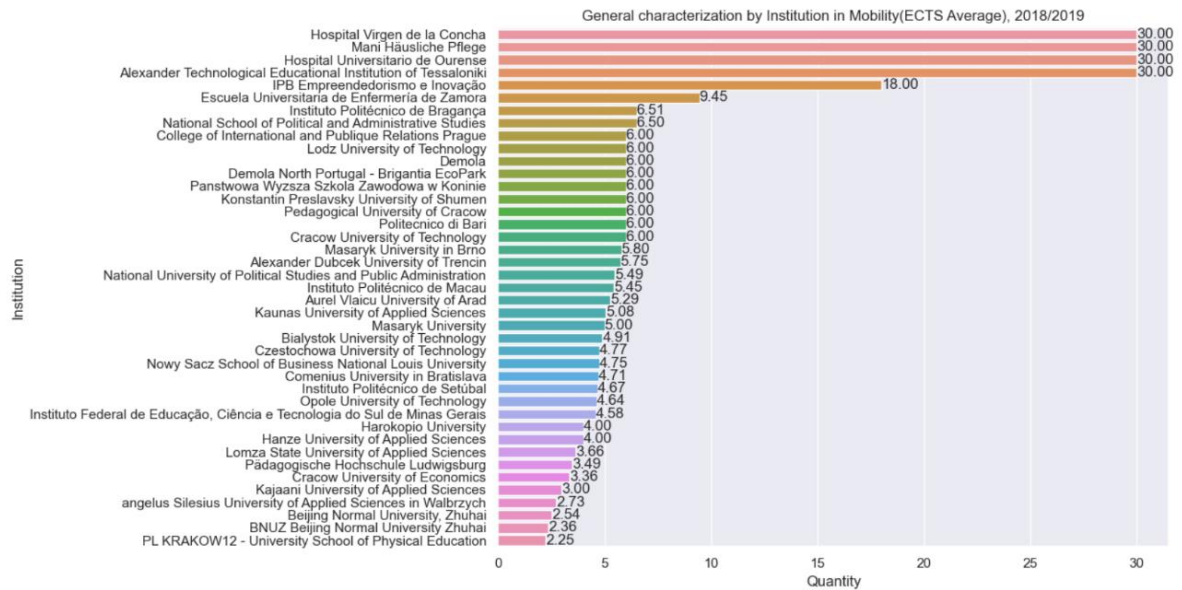

Figure 199: General characterization by Institution in Mobility (Average ECTS), 2018/2019, (1st part)

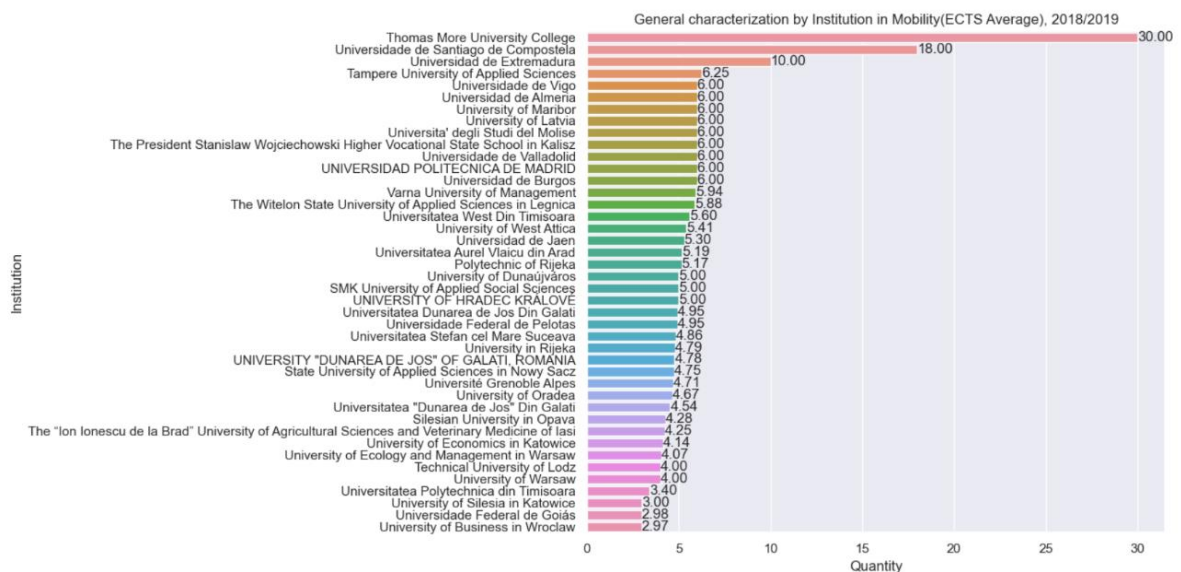

Figure 200: General characterization by Institution in Mobility (Average ECTS), 2018/2019, (2nd part)

The bar chart below shows the average in different institutions. The Y-axis represents institutions, and the X-axis represents the average value. The highest ECTS score was in Hospital Virgen de la Concha at 30.00, Mani Häusliche Pflege at 30.00, Hospital Universitario de Ourense at 30.00, Alexander Technological Educational Institution of Tessaloniki at 30.00,

Thomas More University College at 30.00; the ECTS average score was in PL KRAKOW12 - University School of Physical Education at 2.25.

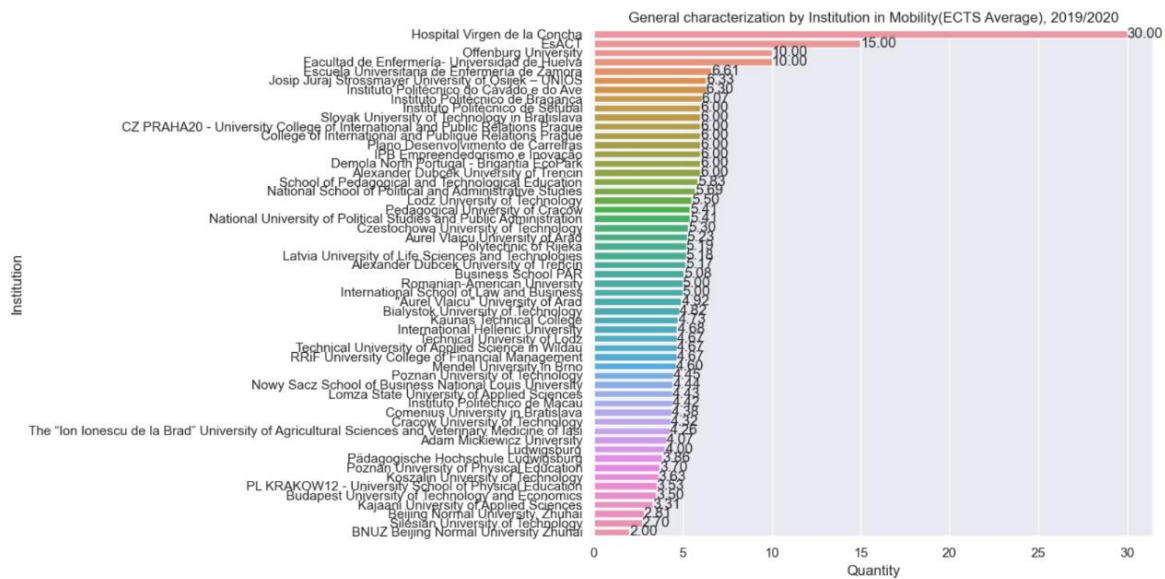

Figure 201: General characterization by Institution in Mobility (Average ECTS), 2019/2020, (1st part)

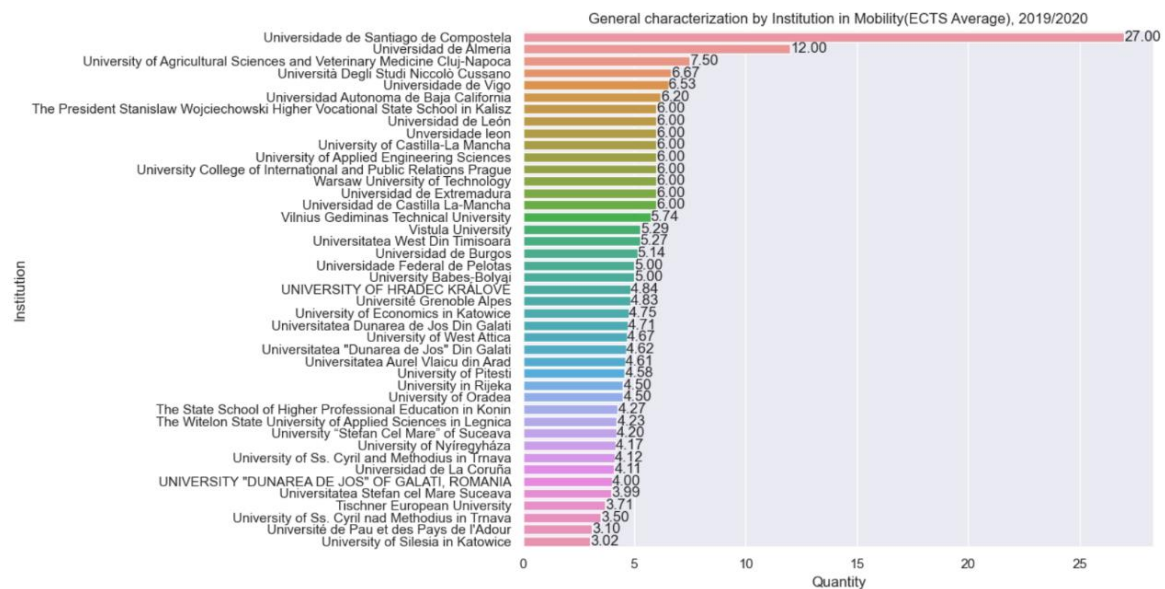

Figure 202: General characterization by Institution in Mobility (Average ECTS), 2019/2020, (2nd part)

The bar chart below shows the average in different institutions. The Y-axis represents institutions, and the X-axis represents the average value. The highest ECTS score was in

Hospital Virgen de la Concha at 30.0; the ECTS average score was in BNUZ Beijing Normal University Zhuhai at 2.00.

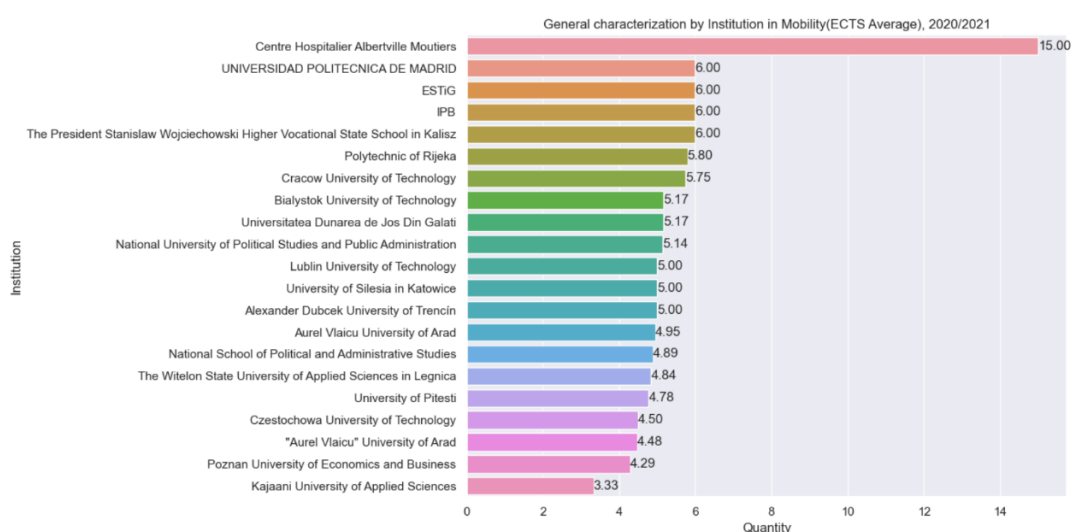

Figure 203: General characterization by Institution in Mobility (Average ECTS), 2020/2021

The bar chart below shows the average in different institutions. The Y-axis represents institutions, and the X-axis represents the average value. The highest ECTS score was in Centre Hospitalier Albertville Moutiers at 15.0; the ECTS average score was in Kajaani University of Applied Sciences at 3.33.

8.2 Tables

Table 1: Number of students by course at ESA in General characterization by Year (Course)

Course	ESA				
	Year				
	2016/2017	2017/2018	2018/2019	2019/2020	2020/2021
Engenharia do Ambiente	19	15	1	6	2
Ciência e Tecnologia Alimentar	3	2	1		
Engenharia Agronómica	17	17	17	13	6
Engenharia Zootécnica	8	7	3	2	1
Enfermagem Veterinária	10	11	8	4	
Viticultura e Enologia	4	2			
Produção Agrícola	4	3			
Tecnologia Alimentar	1	1			
Biologia e Biotecnologia	2	7	8	8	5

Cuidados Veterinários	3				
Gestão de Recursos Florestais		1	4	3	
Engenharia Alimentar				1	
Qualidade e Segurança Alimentar		1	1	1	2
Tecnologias da Ciência Animal				1	2
Agroecologia					2
Engenharia Biotecnológica					3

Table 2: Number of students by course at EsACT in General characterization by Year (Course)

EsACT					
Course	Year				
	2016/2017	2017/2018	2018/2019	2019/2020	2020/2021
Multimédia	19	25	22	12	8
Design de Jogos Digitais	20	33	39	38	25
Marketing	12	15	17	17	10
Gestão e Administração Pública	19	20	16	12	7
Turismo	13	13	8	4	1
Informática e Comunicações	3	5	2	2	
Administração e Negócios	1	1	1		
Informática	2	1			
Comunicação Digital	1	1			
Solicitadoria		2	2	2	
Marketing Turístico				1	1

Table 3: Number of students by course at ESE in General characterization by Year (Course)

ESE					
Course	Year				
	2016/2017	2017/2018	2018/2019	2019/2020	2020/2021
Línguas para Relações Internacionais	63	84	74	52	23
Desporto	25	27	25	12	6
Serviço Social e Desenvolvimento Comunitário	1	1			
Música	2	1			
Arte e Design	7	20	20	17	10
Educação Social	5	9	12	10	4
Línguas Estrangeiras: Inglês e Espanhol	1	3	7	6	5
Desenvolvimento de Produtos Multimédia	6				
Educação Ambiental	1			1	1
Acompanhamento de Crianças e Jovens	1				
Ilustração e Arte Gráfica	1				
Tradução		2	3	3	3
Educação Básica		1	1		
Animação e Produção Artística		1			
TIC na Educação e Formação				1	1
Exercício e Saúde				1	4

Table 4: Number of students by course at ESSa in General characterization by Year (Course)

ESSa					
Course	Year				
	2016/2017	2017/2018	2018/2019	2019/2020	2020/2021
Farmácia	7	6	5	4	2
Enfermagem	67	73	58	36	14
Ciências Biomédicas Laboratoriais	22	24	22	13	7
Dietética e Nutrição	5	5	5	3	1
Gerontologia	2	1			
Bioanálises e Controlo	2	1	1	1	1
Enfermagem Médico-Cirúrgica			1	2	4
Ciências Aplicadas à Saúde			1	2	2

Table 5: Number of students by course at ESTiG

ESTiG					
Course	Year				
	2016/2017	2017/2018	2018/2019	2019/2020	2020/2021
Engenharia Mecânica	38	36	40	36	22
Engenharia Civil	10	13	17	18	14
Engenharia Química e Biológica	8				
Engenharia Industrial	5	14	16	18	17
Engenharia Eletrotécnica e de Computadores	35	44	42	38	23
Gestão	89	97	77	54	40
Gestão de Negócios Internacionais (Curso Europeu)	59	57	58	41	24
Engenharia de Energias Renováveis	41	44	40	31	24
Contabilidade	36	35	20	17	10
Informática de Gestão	37	50	47	38	26
Engenharia Informática	66	94	97	89	60
Sistemas de Informação	1	3	6	3	
Gestão das Organizações	4	11	18	20	18
Engenharia Biomédica	4	3	3	1	1
Tecnologia Biomédica	3	4	3	3	2
Energias Renováveis e Eficiência Energética	1		5	6	5
Tecnologia Mecânica e Veículos	7	10	5		
Energias Renováveis e Instalações Elétricas	8	5			
Planeamento e Condução de Obra	4	2			
Desenvolvimento de Software e Administração de Sistemas	5	2			
Automação, Robótica e Eletrónica Industrial	7	1			
Gestão de Operações e Logística	1				
Análises Químicas e Biológicas	2	2	1		
Engenharia Química		8	8	7	6
Contabilidade e Finanças		1	4	6	8
Tecnologia e Gestão Industrial		7	7	7	3

Desenvolvimento de Software		5	7	3	
Empreendedorismo e Inovação		2	3	3	4
Energias Renováveis e Infraestruturas Elétricas e de Telecomunicações			1	1	
Engenharia da Construção			1	1	1
Inovação de Produtos e Processos					6
Informática					12

Table 6: Number of students by Concelho in Bragança in General characterization by Year (Concelho)

Braganca					
Concelho	Year				
	2016/2017	2017/2018	2018/2019	2019/2020	2020/2021
Mogadouro	8	8	4	3	3
Bragança	182	218	233	210	157
Vila Flor	4	3	3	3	2
Alfândega da Fé	5	4	4	1	1
Miranda do Douro	2	2	2	1	
Mirandela	7	7	5	4	2
Vinhais	4	4	4	4	
Vimioso	3	2	2	1	1
Macedo de Cavaleiros	14	15	13	8	6
Torre de Moncorvo	2	4	4	4	4

Table 7: Number of students by Concelho in Lisboa in General characterization by Year (Concelho)

Lisboa					
Concelho	Year				
	2016/2017	2017/2018	2018/2019	2019/2020	2020/2021
Odivelas	2	1	2	2	1
Amadora	2	1	1	1	1
Lisboa	4	7	7	5	3
Alenquer	1				
Sintra	5	8	7	7	5
Arruda dos Vinhos	1	1			
Vila Franca de Xira	1	1	1		
Loures	1	1	2	1	1
Azambuja	1	1	1		
Oeiras		1	1	1	
Sobral de Monte Agraço		1	1	1	
Lourinhã			1	1	1

Table 8: Number of students by Concelho in Porto in General characterization by Year (Concelho)

Porto					
Concelho	Year				
	2016/2017	2017/2018	2018/2019	2019/2020	2020/2021
Vila Nova de Gaia	3	5	6	6	5
Felgueiras	14	18	14	11	7
Paredes	13	15	16	11	6
Trofa	2	2		1	
Marco de Canaveses	20	22	19	14	10
Santo Tirso	3	5	4	4	1
Penafiel	23	27	21	15	11
Baião	6	7	6	5	3
Paços de Ferreira	6	2	4	3	2
Amarante	14	18	17	11	7
Porto	7	8	7	4	2
Matosinhos	5	6	4	3	
Valongo	2	3	2	3	3
Póvoa de Varzim	5	6	5	3	3
Vila do Conde	3	4	4	1	1
Maia	2	6	7	8	7
Gondomar		3	3	3	

Table 9: Number of students by Concelho in Vila Real in General characterization by Year (Concelho)

Vila Real					
Concelho	Year				
	2016/2017	2017/2018	2018/2019	2019/2020	2020/2021
Valpaços	11	10	10	7	5
Chaves	25	26	22	18	14
Alijó	5	8	6	4	2
Santa Marta de Penaguião	4	3	4	4	3
Mondim de Basto	6	6	5	4	3
Ribeira de Pena	3	3	2	1	1
Vila Real	15	17	11	8	5
Boticas	4	4	4	4	4
Vila Pouca de Aguiar	7	8	8	5	4
Peso da Régua	4	4	3	1	1
Montalegre	4	5	5	5	3
Murça	3	3	3	3	2
Sabrosa	2	2	1	1	

Table 10: Number of students by Type Entry in General characterization by Year

Type Entry					
Type	Year				
	2016/2017	2017/2018	2018/2019	2019/2020	2020/2021
DET	232	181	125	70	37
Maiores 23	10	9	12	8	6
Concurso Nacional de Acesso	314	409	362	270	145
Candidaturas Especiais	10	11	7	7	4
Mudança de Curso	32	40	45	38	23
Transferencia	3	1	1		
Concurso Local	12	35	63	76	98
Estudantes Internacionais	158	205	204	179	120
Regime Geral	5	5	9		5
Mud. Curso Estrangeiros	1				
CTeSP (Titulares ES)	57	28	13	3	

Regime Especial	8	9	2	9	4
CTeSP (Provas de ingresso)	8	8	1	1	1
DTeSP (Titulares CTeSP)		41		69	49

Table 11: Number of students by Nationality in General characterization by Year

Type	Nationality				
	Year				
	2016/2017	2017/2018	2018/2019	2019/2020	2020/2021
Portugal	667	754	662	497	321
Cabo Verde	124	143	141	128	84
Angola	3	4	5	5	5
China	1				
Brasil	10	26	38	38	28
Camarões	1	1	1		
Paquistão	4	6	7	7	4
Nigéria	2		1	1	1
Etiópia	1	1	1		
Síria	2	1	1	1	1
Gana	1	1	1		
Nepal	3	4	4	3	4
Serra Leoa	1	1	1		
Turquia	1	1	1	1	1
São Tomé e Príncipe	17	30	30	29	24
Arménia	1	1	1	1	
Espanha	3	3	3	2	2
Moçambique	2	4	5	5	3
Índia	1	1	1	1	1
Coreia do Sul	1	1	1		
Ucrânia	1	1	1	1	
Timor Leste	1	1	1	1	
Guiné-Bissau	1	2	2	2	1
Guiné Equatorial	1	1	1	1	1
Bielorússia		1			
Gâmbia		1	1	1	1
Bangladesh			7	7	7

Table 12: Number of students by course at ESA in General characterization by Year (Course)

ESA					
Course	Year				
	2016/2017	2017/2018	2018/2019	2019/2020	2020/2021
Engenharia do Ambiente	19	15	1	6	2
Ciência e Tecnologia Alimentar	3	2	1		
Engenharia Agrónómica	17	17	17	13	6
Engenharia Zootécnica	8	7	3	2	1
Enfermagem Veterinária	10	11	8	4	
Viticultura e Enologia	4	2			
Produção Agrícola	4	3			
Tecnologia Alimentar	1	1			
Biologia e Biotecnologia	2	7	8	8	5
Cuidados Veterinários	3				
Gestão de Recursos Florestais		1	4	3	
Engenharia Alimentar				1	
Qualidade e Segurança Alimentar		1	1	1	2
Tecnologias da Ciência Animal				1	2
Agroecologia					2
Engenharia Biotecnológica					3

Table 13: Number of students by course at EsACT in General characterization by Year (Course)

EsACT					
Course	Year				
	2016/2017	2017/2018	2018/2019	2019/2020	2020/2021
Multimédia	19	25	22	12	8
Design de Jogos Digitais	20	33	39	38	25
Marketing	12	15	17	17	10
Gestão e Administração Pública	19	20	16	12	7
Turismo	13	13	8	4	1
Informática e Comunicações	3	5	2	2	
Administração e Negócios	1	1	1		
Informática	2	1			
Comunicação Digital	1	1			
Solicitadoria		2	2	2	
Marketing Turístico				1	1

Table 14: Number of students by course at ESE in General characterization by Year (Course)

Course	ESE				
	Year				
	2016/2017	2017/2018	2018/2019	2019/2020	2020/2021
Línguas para Relações Internacionais	63	84	74	52	23
Desporto	25	27	25	12	6
Serviço Social e Desenvolvimento Comunitário	1	1			
Música	2	1			
Arte e Design	7	20	20	17	10
Educação Social	5	9	12	10	4
Línguas Estrangeiras: Inglês e Espanhol	1	3	7	6	5
Desenvolvimento de Produtos Multimédia	6				
Educação Ambiental	1			1	1
Acompanhamento de Crianças e Jovens	1				
Ilustração e Arte Gráfica	1				
Tradução		2	3	3	3
Educação Básica		1	1		
Animação e Produção Artística		1			
TIC na Educação e Formação				1	1
Exercício e Saúde				1	4

Table 15: Number of students by course at ESSa in General characterization by Year (Course)

Course	ESSa				
	Year				
	2016/2017	2017/2018	2018/2019	2019/2020	2020/2021
Farmácia	7	6	5	4	2
Enfermagem	67	73	58	36	14
Ciências Biomédicas Laboratoriais	22	24	22	13	7
Dietética e Nutrição	5	5	5	3	1
Gerontologia	2	1			
Bioanálises e Controlo	2	1	1	1	1
Enfermagem Médico-Cirúrgica			1	2	4
Ciências Aplicadas à Saúde			1	2	2

Table 16: Number of students by course at ESTiG in General characterization by Year (Course)

ESTiG					
Course	Year				
	2016/2017	2017/2018	2018/2019	2019/2020	2020/2021
Engenharia Mecânica	38	36	40	36	22
Engenharia Civil	10	13	17	18	14
Engenharia Química e Biológica	8				
Engenharia Industrial	5	14	16	18	17
Engenharia Eletrotécnica e de Computadores	35	44	42	38	23
Gestão	89	97	77	54	40
Gestão de Negócios Internacionais (Curso Europeu)	59	57	58	41	24
Engenharia de Energias Renováveis	41	44	40	31	24
Contabilidade	36	35	20	17	10
Informática de Gestão	37	50	47	38	26
Engenharia Informática	66	94	97	89	60
Sistemas de Informação	1	3	6	3	
Gestão das Organizações	4	11	18	20	18
Engenharia Biomédica	4	3	3	1	1
Tecnologia Biomédica	3	4	3	3	2
Energias Renováveis e Eficiência Energética	1		5	6	5
Tecnologia Mecânica e Veículos	7	10	5		
Energias Renováveis e Instalações Elétricas	8	5			
Planeamento e Condução de Obra	4	2			
Desenvolvimento de Software e Administração de Sistemas	5	2			
Automação, Robótica e Eletrónica Industrial	7	1			
Gestão de Operações e Logística	1				
Análises Químicas e Biológicas	2	2	1		
Engenharia Química		8	8	7	6
Contabilidade e Finanças		1	4	6	8
Tecnologia e Gestão Industrial		7	7	7	3

Desenvolvimento de Software		5	7	3	
Empreendedorismo e Inovação		2	3	3	4
Energias Renováveis e Infraestruturas Elétricas e de Telecomunicações			1	1	
Engenharia da Construção			1	1	1
Inovação de Produtos e Processos					6
Informática					12

Table 17: Number of students by Concelho in Bragança in General characterization by School

Bragança					
Concelho	School				
	ESA	EsACT	ESE	ESSa	ESTiG
Mogadouro	13	2	2		26
Bragança	43	43	135	148	1000
Vila Flor	3	8		7	15
Alfândega da Fé	2		2	1	15
Miranda do Douro	1		3	6	7
Mirandela	9	51	20	11	25
Vinhais	7		8	1	16
Vimioso	3		5	3	9
Macedo de Cavaleiros	2	4	4	6	56
Torre de Moncorvo	3	2	4	2	18

Table 18: Number of students by Concelho in Lisboa in General characterization by School

Lisboa					
Concelho	School				
	ESA	EsACT	ESE	ESSa	ESTiG
Odivelas	1		8		
Amadora					6
Lisboa		3	4		19
Alenquer					1
Sintra			3		29
Arruda dos Vinhos		2			
Vila Franca de Xira			3		
Loures				3	3
Azambuja				3	
Oeiras		3			
Sobral de Monte Agraço		3			
Lourinhã		3			

Table 19: Number of students by Concelho in Porto in General characterization by School

Porto					
Concelho	School				
	ESA	EsACT	ESE	ESSa	ESTiG
Vila Nova de Gaia	1	7	10		7
Felgueiras	3	5	13	4	39
Paredes	4	9	23	7	18
Trofa	2				3
Marco de Canaveses	8	6	10	11	50
Santo Tirso	2				15
Penafiel	6	7	18	3	63
Baião	4		3	9	11
Paços de Ferreira	4		7		9
Amarante		12	7		48
Porto	17	5	3		3
Matosinhos		2	4	4	8
Valongo	2	7			4
Póvoa de Varzim		5	6	6	5
Vila do Conde			3	7	3
Maia	5	13			12
Gondomar		6			3

Table 20: Number of students by Concelho in Vila Real in General characterization by School

Vila Real					
Concelho	School				
	ESA	EsACT	ESE	ESSa	ESTiG
Valpaços	4	3	3	5	28
Chaves	6	17	9		73
Alijó		7	6		8
Santa Marta de Penaguião	10		3		5
Mondim de Basto					24
Ribeira de Pena					10
Vila Real	8	5	4	9	5
Boticas					20
Vila Pouca de Aguiar			9		23
Peso da Régua			2	3	8
Montalegre		4		5	13
Murça			4		10
Sabrosa		2			4

Table 21: Number of students by Type Entry in General characterization by School

Type Entry	School				
	ESA	EsACT	ESE	ESSa	ESTiG
DET	117	62	24	30	412
Maiores 23	6	8	13	8	10
Concurso Nacional de Acesso	11	277	387	219	606
Candidaturas Especiais	1		3	19	16
Mudança de Curso	10	37	25	31	75
Transferencia				3	2
Concurso Local	21	2	18	12	231
Estudantes Internacionais	40	43	69	43	671
Regime Geral				12	
Mud. Curso Estrangeiros					1
CTeSP (Titulares ES)	15	8	1	2	66
Regime Especial		5		9	26
CTeSP (Provas de ingresso)	2			5	12
DTeSP (Titulares CTeSP)	28	11	15	7	165

Table 22: Number of students by Nationality in General characterization by School

Nationality					
Nationality	School				
	ESA	EsACT	ESE	ESSa	ESTiG
Portugal	208	386	471	340	1496
Cabo Verde	19	14	68	39	480
Angola	10				12
China					1
Brasil	14	20	21	2	83
Camarões					3

Paquistão					28
Nigéria					5
Etiópia					3
Síria					6
Gana					3
Nepal					18
Serra Leoa					3
Turquia					5
São Tomé e Príncipe		28		12	90
Arménia					4
Espanha				3	10
Moçambique				4	15
Índia					5
Coreia do Sul					3
Ucrânia			4		
Timor Leste					4
Guiné-Bissau		5			3
Guiné Equatorial					5
Bielorússia					1
Gâmbia					4
Bangladesh					21

Table 23: Number of applications for each Type Entry in General characterization School and Course

Number of applications for each Type Entry	
Type Entry	Quantity
DET	412
Transferencia	2
Concurso Local	231
Mudança de Curso	75
Concurso Nacional de Acesso	606
Estudantes Internacionais	671
Candidaturas Especiais	16
Mud. Curso Estrangeiros	1
Regime Especial	26
Maiores 23	10
CTeSP (Titulares ES)	66
CTeSP (Provas de ingresso)	12
DTeSP (Titulares CTeSP)	165

Table 24: Number of applications from each nationality in General characterization School and Course

Number of applications from each nationality	
Nationality	Quantity
Portugal	1496
Cabo Verde	480
Angola	12
China	1
Camarões	3
Paquistão	28
Nigéria	5
Etiópia	3
Síria	6
Gana	3
Nepal	18
Serra Leoa	3
Turquia	5
São Tomé e Príncipe	90
Arménia	4
Brasil	83
Moçambique	15
Índia	5
Coreia do Sul	3
Timor Leste	4
Espanha	10
Guiné Equatorial	5
Bielorússia	1
Gâmbia	4
Guiné-Bissau	3
Bangladesh	21

Table 25: Number of students by course units from each country in 2016/2017 in General characterization by Course in Mobility

Country	Course Unit	Number
Croatia	Engenharia Eletrotécnica e de Computadores	1
Czech Republic	Engenharia Eletrotécnica e de Computadores	1
	Engenharia Industrial	1
	Engenharia Informática	1
	Engenharia Mecânica	1
Espanha	Ciências Biomédicas Laboratoriais	2
	Enfermagem	15
	Farmácia	1
Finland	Design de Jogos Digitais	6
França	Enfermagem	2
Germany	Gestão das Organizações	1
Greece	Ciências Biomédicas Laboratoriais	2
	Engenharia Biomédica	2
Hungary	Engenharia Eletrotécnica e de Computadores	1

	Gestão	3
	Multimédia	1
Latvia	Engenharia do Ambiente	1
Letónia	Engenharia Agronómica	2
Lithuania	Engenharia Civil	1
	Engenharia de Energias Renováveis	5
	Engenharia Eletrotécnica e de Computadores	1
	Engenharia Industrial	1
	Engenharia Informática	1
	Engenharia Mecânica	1
	Gestão e Administração Pública	1
	Multimédia	4
	Turismo	3
Poland	Enfermagem	3
	Engenharia Civil	1
	Engenharia de Energias Renováveis	5
	Engenharia do Ambiente	3
	Engenharia Eletrotécnica e de Computadores	4
	Engenharia Industrial	3
	Engenharia Informática	15
	Engenharia Mecânica	13
	Gestão de Negócios Internacionais (Curso Europeu)	13
	Gestão e Administração Pública	2
	Gestão	15
	Informática de Gestão	4
	Marketing	4
	Sistemas de Informação	1
Polonia	Desporto	2
	Enfermagem	1
Romania	Ciência e Tecnologia Alimentar	2
	Contabilidade	8
	Energias Renováveis e Eficiência Energética	2
	Enfermagem Veterinária	6
	Engenharia Agronómica	5
	Engenharia de Energias Renováveis	8
	Engenharia do Ambiente	4
	Engenharia Zootécnica	3
	Gestão de Recursos Florestais	1
	Gestão	14
	Informática de Gestão	3
	Tecnologia Biomédica	1
Slovakia	Engenharia Industrial	3
	Engenharia Mecânica	2
	Engenharia Química e Biológica	1
	Gestão	2
Slovenia	Engenharia Mecânica	1

	Multimédia	1
Spain	Energias Renováveis e Eficiência Energética	1
	Enfermagem	3
	Engenharia Eletrotécnica e de Computadores	1
United Kingdom	Enfermagem	1

Table 26: Number of students by course units from each country in 2017/2018 in General characterization by Course in Mobility

Country	Course	Number
Alemanha	Línguas para Relações Internacionais	1
Brasil	Desporto	1
	Engenharia Agronómica	1
Bulgaria	Informática de Gestão	5
China	Línguas para Relações Internacionais	5
Croatia	Arte e Design	2
	Gestão	4
	Línguas Estrangeiras: Inglês e Espanhol	1
Czech Republic	Gestão de Negócios Internacionais (Curso Europeu)	5
	Gestão e Administração Pública	2
	Gestão	2
	Informática e Comunicações	1
	Línguas para Relações Internacionais	8
Espanha	Línguas para Relações Internacionais	1
Finland	Design de Jogos Digitais	5
France	Enfermagem	1
Germany	Gestão das Organizações	1
	Línguas para Relações Internacionais	3
Greece	Dietética e Nutrição	2
	Gestão de Negócios Internacionais (Curso Europeu)	3
Hungary	Contabilidade	1
	Gestão	2
Itália	Línguas para Relações Internacionais	1
Lithuania	Engenharia de Energias Renováveis	6
	Engenharia Eletrotécnica e de Computadores	1
	Multimédia	1
	Música	1
	Tecnologia Biomédica	1
Mexico	Farmácia	2
	Gestão de Negócios Internacionais (Curso Europeu)	2
Netherlands	Engenharia Informática	2
Poland	Design de Jogos Digitais	2

	Desporto	5
	Engenharia Civil	2
	Engenharia do Ambiente	5
	Engenharia Eletrotécnica e de Computadores	12
	Engenharia Industrial	3
	Engenharia Informática	7
	Engenharia Mecânica	2
	Engenharia Zootécnica	1
	Gestão de Negócios Internacionais (Curso Europeu)	2
	Gestão e Administração Pública	1
	Gestão	7
	Informática de Gestão	3
	Línguas para Relações Internacionais	4
	Marketing	1
	Multimédia	8
	Turismo	7
Pólonia	Desporto	1
	Desporto	2
	Desporto	4
	Línguas para Relações Internacionais	2
Portugal	Arte e Design	3
	Design de Jogos Digitais	2
	Dietética e Nutrição	1
	Educação Social	2
	Engenharia Agronómica	3
	Engenharia Alimentar	1
	Engenharia Civil	1
	Engenharia de Energias Renováveis	1
	Engenharia Eletrotécnica e de Computadores	1
	Engenharia Informática	11
	Engenharia Química	2
	Farmácia	1
	Gestão das Organizações	3
	Gestão de Negócios Internacionais (Curso Europeu)	5
	Informática e Comunicações	1
	Línguas para Relações Internacionais	1
	Marketing	1
	Serviço Social e Desenvolvimento Comunitário	1
	Sistemas de Informação	2
	Tecnologia e Gestão Industrial	1
Tradução	1	
Turismo	3	
Republica Checa	Desporto	3
	Línguas para Relações Internacionais	3
Romania	Ciência e Tecnologia Alimentar	1

	Contabilidade e Finanças	1
	Contabilidade	7
	Enfermagem Veterinária	2
	Engenharia Agronómica	4
	Engenharia de Energias Renováveis	4
	Engenharia do Ambiente	3
	Engenharia Eletrotécnica e de Computadores	1
	Engenharia Industrial	1
	Engenharia Mecânica	1
	Engenharia Química	1
	Engenharia Zootécnica	6
	Gestão das Organizações	1
	Gestão	14
	Informática de Gestão	6
	Línguas para Relações Internacionais	1
	Educação Social	1
Roméia	Educação Social	1
Slovakia	Engenharia Química	3
	Gestão das Organizações	1
	Gestão de Negócios Internacionais (Curso Europeu)	6
	Gestão	2
Slovenia	Multimédia	1
	Sistemas de Informação	1
Spain	Biologia e Biotecnologia	1
	Ciências Biomédicas Laboratoriais	2
	Enfermagem	20
	Gestão de Negócios Internacionais (Curso Europeu)	4
	Línguas para Relações Internacionais	5

Table 27: Number of students by course units from each country in 2018/2019 in General characterization by Course in Mobility

Country	Course	Number
Alemanha	Línguas para Relações Internacionais	1
Belgium	Dietética e Nutrição	1
Brasil	Desporto	1
	Educação Básica	1
	Multimédia	1
	Desporto	1
	Educação Social	1
	Enfermagem	1
	Línguas para Relações Internacionais	2
Bulgaria	Gestão de Negócios Internacionais (Curso Europeu)	3
	Informática de Gestão	5
China	Línguas para Relações Internacionais	8

Croatia	Engenharia Civil	5
	Engenharia Informática	5
	Gestão	2
Czech Republic	Contabilidade	3
	Engenharia Informática	2
	Gestão de Negócios Internacionais (Curso Europeu)	1
	Gestão e Administração Pública	1
	Gestão	1
	Línguas para Relações Internacionais	16
Finland	Design de Jogos Digitais	1
	Marketing	1
France	Gestão de Negócios Internacionais (Curso Europeu)	1
Germany	Enfermagem	1
	Línguas para Relações Internacionais	2
Greece	Ciências Biomédicas Laboratoriais	4
	Dietética e Nutrição	2
	Engenharia de Energias Renováveis	1
	Gestão de Negócios Internacionais (Curso Europeu)	4
Hungary	Engenharia Industrial	2
	Engenharia Mecânica	4
Italy	Enfermagem	2
	Engenharia Eletrotécnica e de Computadores	1
Latvia	Marketing	2
Lithuania	Engenharia de Energias Renováveis	3
	Gestão e Administração Pública	3
Macau	Farmácia	1
Poland	Arte e Design	3
	Desporto	5
	Educação Social	5
	Engenharia Biomédica	1
	Engenharia de Energias Renováveis	1
	Engenharia do Ambiente	2
	Engenharia Eletrotécnica e de Computadores	2
	Engenharia Informática	15
	Engenharia Mecânica	3
	Gestão das Organizações	1
	Gestão de Negócios Internacionais (Curso Europeu)	4
	Gestão	9
	Informática de Gestão	5
	Línguas para Relações Internacionais	4
	Marketing	4
	Multimédia	10
	Sistemas de Informação	1
Tecnologia Biomédica	1	
Turismo	1	
Portugal	Administração e Negócios	1

	Arte e Design	4
	Contabilidade e Finanças	2
	Design de Jogos Digitais	2
	Energias Renováveis e Eficiência Energética	1
	Energias Renováveis e Infraestruturas Elétricas e de Telecomunicações	1
	Engenharia Agronómica	4
	Engenharia Biomédica	1
	Engenharia Civil	7
	Engenharia de Energias Renováveis	3
	Engenharia Eletrotécnica e de Computadores	14
	Engenharia Industrial	5
	Engenharia Informática	15
	Engenharia Mecânica	2
	Farmácia	2
	Gestão de Negócios Internacionais (Curso Europeu)	8
	Gestão de Recursos Florestais	1
	Informática de Gestão	8
	Línguas para Relações Internacionais	2
	Qualidade e Segurança Alimentar	1
Romania	Contabilidade	4
	Enfermagem Veterinária	2
	Engenharia Agronómica	4
	Engenharia de Energias Renováveis	4
	Engenharia Eletrotécnica e de Computadores	3
	Engenharia Industrial	2
	Engenharia Informática	1
	Engenharia Mecânica	1
	Gestão de Negócios Internacionais (Curso Europeu)	1
	Gestão e Administração Pública	5
	Gestão	11
	Informática de Gestão	9
	Línguas para Relações Internacionais	6
	Tecnologia e Gestão Industrial	1
Slovakia	Engenharia Mecânica	5
	Gestão das Organizações	1
	Gestão de Negócios Internacionais (Curso Europeu)	2
	Gestão	2
Slovenia	Engenharia Eletrotécnica e de Computadores	3
	Engenharia Informática	1
Spain	Biologia e Biotecnologia	2
	Ciências Biomédicas Laboratoriais	10
	Enfermagem	29
	Engenharia do Ambiente	1
	Gestão de Negócios Internacionais (Curso Europeu)	2
	Gestão	1
Informática de Gestão	1	

	Línguas para Relações Internacionais	1
	Tecnologia e Gestão Industrial	1
	Turismo	1
The Netherlands	Design de Jogos Digitais	3

Table 28: Number of students by course units from each country in 2019/2020 in General characterization by Course in Mobility

Country	Course	Number
Brasil	Farmácia	1
China	Gestão de Negócios Internacionais (Curso Europeu)	2
	Línguas Estrangeiras: Inglês e Espanhol	1
Croat	Engenharia Civil	1
Croatia	Arte e Design	1
	Engenharia Civil	1
	Engenharia Eletrotécnica e de Computadores	3
	Engenharia Informática	1
	Gestão de Negócios Internacionais (Curso Europeu)	4
	Gestão	7
Czech Republic	Gestão de Negócios Internacionais (Curso Europeu)	3
	Línguas para Relações Internacionais	6
	Marketing	5
Espanha	Línguas para Relações Internacionais	3
Finland	Design de Jogos Digitais	3
France	Gestão de Negócios Internacionais (Curso Europeu)	1
	Línguas para Relações Internacionais	2
Germany	Gestão de Negócios Internacionais (Curso Europeu)	1
	Línguas para Relações Internacionais	2
	Multimédia	1
Greece	Ciências Biomédicas Laboratoriais	2
	Engenharia de Energias Renováveis	3
	Engenharia Eletrotécnica e de Computadores	1
Hungary	Arte e Design	6
	Informática de Gestão	1
Hungria	Arte e Design	1
Italy	Educação Social	1
Latvia	Engenharia Agronómica	2
Lithuania	Engenharia Civil	2

	Engenharia Eletrotécnica e de Computadores	4
	Engenharia Mecânica	2
	Gestão de Negócios Internacionais (Curso Europeu)	1
	Marketing	1
Macau	Enfermagem	2
	Línguas Estrangeiras: Inglês e Espanhol	2
México	Línguas para Relações Internacionais	1
	Arte e Design	3
	Biologia e Biotecnologia	2
	Contabilidade	1
	Design de Jogos Digitais	1
	Desporto	6
	Engenharia Civil	2
	Engenharia do Ambiente	1
	Engenharia Eletrotécnica e de Computadores	4
	Engenharia Industrial	2
	Engenharia Informática	23
Poland	Engenharia Mecânica	8
	Engenharia Química	2
	Gestão de Negócios Internacionais (Curso Europeu)	1
	Gestão	2
	Línguas Estrangeiras: Inglês e Espanhol	2
	Línguas para Relações Internacionais	8
	Marketing	1
	Multimédia	5
	Sistemas de Informação	2
	Tecnologia Biomédica	2
	Turismo	2
	Arte e Design	5
	Biologia e Biotecnologia	4
	Design de Jogos Digitais	33
	Desporto	1
	Engenharia Civil	3
	Engenharia de Energias Renováveis	1
	Engenharia do Ambiente	1
Portugal	Engenharia Eletrotécnica e de Computadores	15
	Engenharia Industrial	5
	Engenharia Informática	32
	Engenharia Mecânica	2
	Gestão de Negócios Internacionais (Curso Europeu)	8
	Gestão de Recursos Florestais	1

	Informática de Gestão	44
	Informática e Comunicações	2
	Sistemas de Informação	1
	Solicitadoria	2
	Tecnologia e Gestão Industrial	3
Romania	Contabilidade e Finanças	3
	Contabilidade	9
	Desporto	2
	Educação Social	2
	Energias Renováveis e Eficiência Energética	1
	Engenharia Agronómica	1
	Engenharia de Energias Renováveis	10
	Engenharia Industrial	2
	Engenharia Informática	1
	Engenharia Mecânica	5
	Engenharia Zootécnica	1
	Gestão das Organizações	1
	Gestão de Negócios Internacionais (Curso Europeu)	5
	Gestão e Administração Pública	4
	Gestão	17
	Informática de Gestão	2
	Tecnologia e Gestão Industrial	3
Roména	Enfermagem Veterinária	1
Roménia	Enfermagem Veterinária	2
	Engenharia Agronómica	2
Slovakia	Engenharia Mecânica	4
	Engenharia Química	1
	Gestão	1
	Marketing	3
	Sistemas de Informação	1
Spain	Ciências Biomédicas Laboratoriais	9
	Energias Renováveis e Eficiência Energética	2
	Enfermagem	22
	Engenharia da Construção	1
	Engenharia de Energias Renováveis	1
	Engenharia Eletrotécnica e de Computadores	1
	Línguas Estrangeiras: Inglês e Espanhol	3
	Línguas para Relações Internacionais	3
	Tradução	1

Table 29: Number of students by course units from each country in 2020/2021 in General characterization by Course in Mobility

Country	Course	Number
Croatia	Engenharia Informática	3
Finland	Design de Jogos Digitais	1
France	Enfermagem	1
Poland	Design de Jogos Digitais	1
	Engenharia Informática	6
	Engenharia Mecânica	5
	Engenharia Química	1
	Gestão e Administração Pública	1
	Gestão	6
	Informática de Gestão	1
	Informática	1
Portugal	Agroecologia	1
	Arte e Design	1
	Bioanálises e Controlo	1
	Biologia e Biotecnologia	1
	Ciências Biomédicas Laboratoriais	1
	Design de Jogos Digitais	10
	Educação Ambiental	2
	Engenharia Agronómica	1
	Engenharia Informática	7
	Gestão	1
Romania	Contabilidade	1
	Engenharia Informática	1
	Engenharia Mecânica	4
	Gestão de Negócios Internacionais (Curso Europeu)	2
	Gestão e Administração Pública	1
	Gestão	8
Slovakia	Engenharia Química	1
Spain	Engenharia Mecânica	1

Table 30: Number of students by course units from each institution in 2016/2017 in General characterization by Course in Mobility(Institution)

Course	Institution	Number
Ciência e Tecnologia Alimentar	The "Ion Ionescu de la Brad" University of Agricultural Sciences and Veterinary Medicine of Iasi	2
Ciências Biomédicas Laboratoriais	Alexander Technological Educational Institution of Tessaloniki	2
	Hospital Virgen de la Concha	2
Contabilidade	Academia de Studii Economice din Bucuresti	3
	Universitatea Din Pitesti	5
Design de Jogos Digitais	Kajaani University of Applied Sciences	6
Desporto	PL KRAKOW12 - University School of Physical Education	2
Energias Renováveis e Eficiência Energética	Universidade da Coruña	1
	Universitatea Stefan cel Mare Suceava	2
Enfermagem Veterinária	The "Ion Ionescu de la Brad" University of Agricultural Sciences and Veterinary Medicine of Iasi	4
	University of Agricultural Sciences and Veterinary Medicine	2
Enfermagem	Escuela Universitaria de Enfermería de Zamora	17
	Facultad de Ciencias de la Salud - Universidade de Leon	1
	Institut de Formation en Soins Infirmiers Virginie Olivier	2
	Sussex Health Care	1
	The President Stanislaw Wojciechowski Higher Vocational State School in Kalisz	4
Engenharia Agronómica	Latvia University of Agriculture	2
	The "Ion Ionescu de la Brad" University of Agricultural Sciences and Veterinary Medicine of Iasi	3
	Universitatea Aurel Vlaicu din Arad	2
Engenharia Biomédica	School of Pedagogical and Technological Education	2
Engenharia Civil	Bialystok University of Technology	1
	Vilnius College of Technologies and Design	1
Engenharia de Energias Renováveis	Cracow University of Technology	2
	Kauno Kolegija - University of Applied Sciences	5

	Lodz University of Technology	3
	Universitatea Polytechnica din Timisoara	2
	Universitatea Stefan cel Mare Suceava	6
Engenharia do Ambiente	Bialystok University of Technology	3
	Latvia University of Agriculture	1
	The "Ion Ionescu de la Brad" University of Agricultural Sciences and Veterinary Medicine of Iasi	4
Engenharia Eletrotécnica e de Computadores	Koszalin University of Technology	3
	Technical University of Ostrava	1
	Universidade da Coruña	1
	University of Split	1
	University of Technology and Economics Budapest	1
	Vilniaus Gediminas Technical University	1
	Wroclaw University of Technology	1
Engenharia Industrial	Alexander Dubcek University of Trencin	2
	Alexander Ducek University Trencin	1
	Technical University of Ostrava	1
	The President Stanislaw Wojciechowski Higher Vocational State School in Kalisz	3
	Vilniaus Gediminas Technical University	1
Engenharia Informática	Bialystok University of Technology	1
	Czestochowa University of Technology	7
	Lodz University of Technology	1
	Poznan University of Technology	4
	Technical University of Ostrava	1
	Vilnius Gediminas Technical University	1
	Vistula University	1
	Wroclaw University of Technology	1
Engenharia Mecânica	Alexander Dubcek University of Trencin	1
	Alexander Ducek University Trencin	2
	Technical University of Ostrava	1

	The President Stanislaw Wojciechowski Higher Vocational State School in Kalisz	13
	Vilnius Gediminas Technical University	1
Engenharia Química e Biológica	Alexander Dubcek University of Trencin	1
Engenharia Zootécnica	The "Ion Ionescu de la Brad" University of Agricultural Sciences and Veterinary Medicine of Iasi	2
	University of Agricultural Sciences and Veterinary Medicine Cluj-Napoca	1
Farmácia	Universidade de Sevilha	1
Gestão das Organizações	Technical University of Applied Science in Wildau	1
Gestão de Negócios Internacionais (Curso Europeu)	The President Stanislaw Wojciechowski Higher Vocational State School in Kalisz	13
Gestão de Recursos Florestais	The "Ion Ionescu de la Brad" University of Agricultural Sciences and Veterinary Medicine of Iasi	1
Gestão e Administração Pública	Kauno Kolegija - University of Applied Sciences	1
	Panstwowa Wyzsza Szkola Zawodowa w Koninie	2
Gestão	Aurel Vlaicu University of Arad	2
	Aurel Vlaicu "University of Arad"	3
	Comenius University in Bratislava	2
	Gdansk School of Banking	3
	National School of Political and Administrative Studies	5
	National University of Political Studies and Public Administration	4
	Panstwowa Wyzsza Szkola Zawodowa w Koninie	4
	University of Dunaújváros	3
	University of Ecology and Management in Warsaw	6
	University of Warmia and Mazury in Olsztyn	1
	Wroclaw University of Technology	1
Informática de Gestão	Czestochowa University of Technology	1
	University of Economics and Innovation in Lublin	2
	University of Oradea	4
Marketing	Vistula University	4
Multimédia	Kauno Kolegija - University of Applied Sciences	4

	Obuda University- John Von Neumann Faculty of Informatics	1
	University of Maribor	1
Sistemas de Informação	Czestochowa University of Technology	1
Tecnologia Biomédica	Universitatea Polytechnica din Timisoara	1
Turismo	Kauno Kolegija - University of Applied Sciences	3

Table 31: Number of students by course units from each institution in 2017/2018 in General characterization by Course in Mobility(Institution)

Course	Institution	Number
Arte e Design	Démola Project	1
	Instituto Politécnico do Cávado e do Ave	1
	Instituto Politécnico do Porto	1
	University of Zagreb	2
Biologia e Biotecnologia	Universidad de Jaen	1
Ciência e Tecnologia Alimentar	The “Ion Ionescu de la Brad” University of Agricultural Sciences and Veterinary Medicine of Iasi	1
Ciências Biomédicas Laboratoriais	EOXI DE OURENSE, VENIX E O BARCO DE VALDEORMS	1
	Hospital Virgen de la Concha	1
Contabilidade e Finanças	Universitatea Din Pitesti	1
Contabilidade	Universitatea Din Pitesti	5
	Universitatea West Din Timisoara	2
	University of Dunaújváros	1
Design de Jogos Digitais	Instituto Politécnico de Bragança	2
	Kajaani University of Applied Sciences	5
	University of Silesia in Katowice	2
Desporto	PL KRAKOW12 - University School of Physical Education	12
	Universidade Federal de Goiás	1
	UNIVERSITY OF HRADEC KRÁLOVÉ	3
Dietética e Nutrição	Harokopio University	2

	IPB	1
Educação Social	Aurel Vlaicu University of Arad	2
	Démola Project	1
	Instituto Politécnico do Porto	1
Enfermagem Veterinária	The “Ion Ionescu de la Brad” University of Agricultural Sciences and Veterinary Medicine of Iasi	2
Enfermagem	Escuela Universitaria de Enfermería de Zamora	19
	Institut de Formation en Soins Infirmiers Virginie Olivier	1
	Universidad de Salamanca	1
Engenharia Agronómica	Instituto Politécnico de Bragança	3
	The “Ion Ionescu de la Brad” University of Agricultural Sciences and Veterinary Medicine of Iasi	4
	Universidade Federal de Mato Grosso	1
Engenharia Alimentar	Instituto Politécnico de Bragança	1
Engenharia Civil	Czestochowa University of Technology	2
	Instituto Politécnico de Bragança	1
Engenharia de Energias Renováveis	Instituto Politécnico de Bragança	1
	Kaunas University of Applied Sciences	4
	Universitatea Aurel Vlaicu din Arad	2
	Universitatea Stefan cel Mare Suceava	2
	Vilnius Gediminas Technical University	2
Engenharia do Ambiente	Opole University of Technology	5
	The “Ion Ionescu de la Brad” University of Agricultural Sciences and Veterinary Medicine of Iasi	3
Engenharia Eletrotécnica e de Computadores	Czestochowa University of Technology	2
	Instituto Politécnico de Bragança	1
	Kaunas University of Applied Sciences	1
	Koszalin University of Technology	5
	Technical University of Lodz	2

	The President Stanislaw Wojciechowski Higher Vocational State School in Kalisz	3
	Universitatea Stefan cel Mare Suceava	1
Engenharia Industrial	Koszalin University of Technology	4
Engenharia Informática	Czestochowa University of Technology	2
	Instituto Politécnico de Bragança	11
	Koszalin University of Technology	1
	Opole University of Technology	2
	The President Stanislaw Wojciechowski Higher Vocational State School in Kalisz	1
	Windsheim University of Applied Sciences	2
	Wroclaw University of Science and Technology	1
Engenharia Mecânica	The President Stanislaw Wojciechowski Higher Vocational State School in Kalisz	2
	Universitatea Aurel Vlaicu din Arad	1
Engenharia Química	Alexander Dubcek University of Trencin	3
	Instituto Politécnico de Bragança	2
	Universitatea Aurel Vlaicu din Arad	1
Engenharia Zootécnica	Bialystok University of Technology	1
	The "Ion Ionescu de la Brad" University of Agricultural Sciences and Veterinary Medicine of Iasi	2
	University of Agricultural Sciences and Veterinary Medicine Cluj-Napoca	4
Farmácia	IPB	1
	Universidad Autonoma de Baja California	2
Gestão das Organizações	Comenius University in Bratislava	1
	Instituto Politécnico de Bragança	3
	Universitatea Aurel Vlaicu din Arad	1
	University of Applied Sciences	1
	Comenius University in Bratislava	6

Gestão de Negócios Internacionais (Curso Europeu)	Instituto Politécnico de Bragança	5
	Silesian University in Opava	5
	TEI Piraeus	3
	The President Stanislaw Wojciechowski Higher Vocational State School in Kalisz	2
	Universidad Autónoma de Baja California	2
	Universidad de Huelva	3
	Universidad de Jaen	1
Gestão e Administração Pública	Silesian University in Opava	2
	University of Business in Wroclaw	1
Gestão	Comenius University in Bratislava	2
	National School of Political and Administrative Studies	10
	Panstwowa Wyzsza Szkola Zawodowa w Koninie	2
	RRiF University College of Financial Management	4
	Universitatea Aurel Vlaicu din Arad	2
	Universitatea Din Pitesti	1
	University Babes-Bolyai	2
	University of Dunaújváros	2
	University of Pardubice	2
Wroclaw University of Science and Technology	4	
Informática de Gestão	Konstantin Preslavsky University of Shumen	5
	Universitatea "Dunarea de Jos" Din Galati	1
	Universitatea Dunarea de Jos Din Galati	2
	University of Economics and Innovation in Lublin	3
	University of Oradea	3
Informática e Comunicações	Instituto Politécnico de Bragança	1
	University of Pardubice	1
Línguas Estrangeiras: Inglês e Espanhol	University of Zagreb	1
	Beijing Normal University, Zhuhai	1

Línguas para Relações Internacionais	BNUZ Beijing Normal University Zhuhai	4
	College of International and Public Relations Prague	3
	CZ PRAHA20 - University College of International and Public Relations Prague	6
	Démola Project	1
	Johannes Gutenberg-Universität Mainz	3
	Ludwigsburg	1
	Tischner European University	6
	Universidad de Valladolid	1
	Università Di Bologna	1
	UNIVERSITY "DUNAREA DE JOS" OF GALATI, ROMANIA	1
	University College of International and Public Relations Prague	2
	UNIVERSITY OF CASTILLA-LA MANCHA	5
	Marketing	Instituto Politécnico de Bragança
Vistula University		1
Multimédia	Bialystok University of Technology	2
	Kauno Kolegija - University of Applied Sciences	1
	University of Maribor	1
	University of Silesia in Katowice	6
Música	LT VILNIUS04 - Vilnius Pedagogical University	1
Serviço Social e Desenvolvimento Comunitário	Demola	1
Sistemas de Informação	Instituto Politécnico de Bragança	2
	University of Maribor	1
Tecnologia Biomédica	Vilniaus Gediminas Technical University	1
Tecnologia e Gestão Industrial	Instituto Politécnico de Bragança	1
Tradução	Démola Project	1
Turismo	Instituto Politécnico de Bragança	3
	University of Business in Wroclaw	2

Table 32: Number of students by course units from each institution in 2018/2019 in General characterization by Course in Mobility(Institution)

Course	Institution	Number
Administração e Negócios	Instituto Politécnico de Bragança	1
Arte e Design	Demola North Portugal - Brigantia EcoPark	4
	Pedagogical University of Cracow	3
Biologia e Biotecnologia	Universidad de Jaen	2
Ciências Biomédicas Laboratoriais	Alexander Technological Educational Institution of Tesseloniki	4
	Hospital Universitario de Ourense	1
	Hospital Virgen de la Concha	9
Contabilidade e Finanças	Instituto Politécnico de Bragança	2
Contabilidade	Silesian University in Opava	3
	Universitatea West Din Timisoara	4
Design de Jogos Digitais	Hanze University of Applied Sciences	3
	Instituto Politécnico de Bragança	2
	Kajaani University of Applied Sciences	1
Desporto	Lomza State University of Applied Sciences	3
	PL KRAKOW12 - University School of Physical Education	2
	Universidade Federal de Goiás	2
Dietética e Nutrição	Harokopio University	2
	Thomas More University College	1
Educação Básica	Universidade Federal de Pelotas	1
Educação Social	angelus Silesius University of Applied Sciences in Walbrzych	5
	Instituto Federal de Educação, Ciência e Tecnologia do Sul de Minas Gerais	1

Energias Renováveis e Eficiência Energética	Instituto Politécnico de Bragança	1
Energias Renováveis e Infraestruturas Elétricas e de Telecomunicações	Instituto Politécnico de Bragança	1
Enfermagem Veterinária	The "Ion Ionescu de la Brad" University of Agricultural Sciences and Veterinary Medicine of Iasi	2
Enfermagem	Escuela Universitaria de Enfermería de Zamora	23
	Mani Häusliche Pflege	1
	Universidad de Extremadura	3
	Universidade de Santiago de Compostela	3
	Universidade Federal de Goiás	1
	Universita' degli Studi del Molise	2
Engenharia Agronómica	Demola North Portugal - Brigantia EcoPark	4
	The "Ion Ionescu de la Brad" University of Agricultural Sciences and Veterinary Medicine of Iasi	4
Engenharia Biomédica	Instituto Politécnico de Setúbal	1
	Lodz University of Technology	1
Engenharia Civil	Instituto Politécnico de Bragança	7
	University in Rijeka	5
Engenharia de Energias Renováveis	Instituto Politécnico de Bragança	3
	Kaunas University of Applied Sciences	3
	Technical University of Lodz	1
	Universitatea Polytechnica din Timisoara	2
	Universitatea Stefan cel Mare Suceava	2
	University of West Attica	1
Engenharia do Ambiente	Opole University of Technology	2
	UNIVERSIDAD POLITECNICA DE MADRID	1
Engenharia Eletrotécnica e de Computadores	Bialystok University of Technology	2
	Instituto Politécnico de Bragança	14
	Politecnico di Bari	1

	Universitatea Polytechnica din Timisoara	2
	Universitatea Stefan cel Mare Suceava	1
	University of Maribor	3
Engenharia Industrial	Instituto Politécnico de Bragança	5
	Universitatea Stefan cel Mare Suceava	2
	University of Dunaújváros	2
Engenharia Informática	Cracow University of Technology	3
	Czestochowa University of Technology	5
	Instituto Politécnico de Bragança	15
	Lomza State University of Applied Sciences	5
	Polytechnic of Rijeka	5
	The Witelon State University of Applied Sciences in Legnica	2
	UNIVERSITY OF HRADEC KRÁLOVÉ	2
	University of Maribor	1
	University of Oradea	1
Engenharia Mecânica	Alexander Dubcek University of Trencin	5
	Instituto Politécnico de Bragança	2
	The President Stanislaw Wojciechowski Higher Vocational State School in Kalisz	3
	Universitatea Aurel Vlaicu din Arad	1
	University of Dunaújváros	4
Farmácia	Instituto Politécnico de Bragança	2
	Instituto Politécnico de Macau	1
Gestão das Organizações	Comenius University in Bratislava	1
	The President Stanislaw Wojciechowski Higher Vocational State School in Kalisz	1
Gestão de Negócios Internacionais (Curso Europeu)	Comenius University in Bratislava	2
	Cracow University of Economics	3
	Instituto Politécnico de Bragança	8

	Masaryk University in Brno	1
	Universidad de Almeria	1
	Universidad de Jaen	1
	Universitatea Dunarea de Jos Din Galati	1
	Université Grenoble Alpes	1
	University of Warsaw	1
	University of West Attica	4
	Varna University of Management	3
Gestão de Recursos Florestais	Demola North Portugal - Brigantia EcoPark	1
Gestão e Administração Pública	Masaryk University	1
	National University of Political Studies and Public Administration	5
	SMK University of Applied Social Sciences	3
Gestão	Alexander Dubcek University of Trencin	1
	Bialystok University of Technology	2
	Comenius University in Bratislava	1
	National School of Political and Administrative Studies	4
	Panstwowa Wyzsza Szkola Zawodowa w Koninie	4
	Polytechnic of Rijeka	2
	Silesian University in Opava	1
	Universidade de Vigo	1
	Universitatea Aurel Vlaicu din Arad	7
	University of Ecology and Management in Warsaw	3
Informática de Gestão	Instituto Politécnico de Bragança	8
	Konstantin Preslavsky University of Shumen	5
	The Witelon State University of Applied Sciences in Legnica	5
	Universidad de Burgos	1
	Universitatea "Dunarea de Jos" Din Galati	1
	Universitatea Dunarea de Jos Din Galati	3

	Universitatea Stefan cel Mare Suceava	1
	University of Oradea	4
Línguas para Relações Internacionais	angelus Silesius University of Applied Sciences in Walbrzych	2
	Beijing Normal University, Zhuhai	5
	BNUZ Beijing Normal University Zhuhai	2
	College of International and Public Relations Prague	16
	Demola North Portugal - Brigantia EcoPark	1
	Demola	1
	Instituto Politécnico de Macau	1
	Nowy Sacz School of Business National Louis University	1
	Pädagogische Hochschule Ludwigsburg	3
	State University of Applied Sciences in Nowy Sacz	1
	Universidade de Santiago de Compostela	1
	Universidade Federal de Pelotas	2
	Universitatea "Dunarea de Jos" Din Galati	5
	UNIVERSITY "DUNAREA DE JOS" OF GALATI, ROMANIA	1
Marketing	Tampere University of Applied Sciences	1
	University of Business in Wroclaw	2
	University of Economics in Katowice	2
	University of Latvia	2
Multimédia	Instituto Federal de Educação, Ciência e Tecnologia do Sul de Minas Gerais	1
	University of Silesia in Katowice	10
Qualidade e Segurança Alimentar	IPB Empreendedorismo e Inovação	1
Sistemas de Informação	Czestochowa University of Technology	1
Tecnologia Biomédica	Technical University of Lodz	1
Tecnologia e Gestão Industrial	Universidad de Burgos	1
	Universitatea Dunarea de Jos Din Galati	1
Turismo	Universidade de Valladolid	1

Table 33: Number of students by course units from each institution in 2019/2020 in General characterization by Course in Mobility(Institution)

Course	Institution	Number
Arte e Design	Demola North Portugal - Brigantia EcoPark	5
	Pedagogical University of Cracow	3
	University in Rijeka	1
	University of Nyíregyháza	7
Biologia e Biotecnologia	Adam Mickiewicz University	2
	Instituto Politécnico de Bragança	3
	IPB Empreendedorismo e Inovação	1
Ciências Biomédicas Laboratoriais	Hospital Virgen de la Concha	9
	International Hellenic University	2
Contabilidade e Finanças	National School of Political and Administrative Studies	3
Contabilidade	The President Stanislaw Wojciechowski Higher Vocational State School in Kalisz	1
	Universitatea West Din Timisoara	6
	University of Pitesti	3
Design de Jogos Digitais	Instituto Politécnico de Bragança	33
	Kajaani University of Applied Sciences	3
	University of Silesia in Katowice	1
Desporto	PL KRAKOW12 - University School of Physical Education	6
	Plano Desenvolvimento de Carreiras	1
	Universitatea "Dunarea de Jos" Din Galati	1
	UNIVERSITY "DUNAREA DE JOS" OF GALATI, ROMANIA	1
Educação Social	Università Degli Studi Niccolò Cussano	1

	University of Oradea	2
Energias Renováveis e Eficiência Energética	Universidad de Burgos	1
	Universidad de La Coruña	1
	Universitatea Stefan cel Mare Suceava	1
Enfermagem Veterinária	The “Ion Ionescu de la Brad” University of Agricultural Sciences and Veterinary Medicine of Iasi	2
	University of Agricultural Sciences and Veterinary Medicine Cluj-Napoca	1
Enfermagem	Escuela Universitaria de Enfermería de Zamora	15
	Facultad de Enfermería- Universidad de Huelva	3
	Instituto Politécnico de Macau	2
	Universidad de Almeria	3
	Universidade de Santiago de Compostela	1
Engenharia Agronómica	Latvia University of Life Sciences and Technologies	2
	The “Ion Ionescu de la Brad” University of Agricultural Sciences and Veterinary Medicine of Iasi	2
	University of Agricultural Sciences and Veterinary Medicine Cluj-Napoca	1
Engenharia Civil	Bialystok University of Technology	2
	Instituto Politécnico de Bragança	3
	University in Rijeka	2
	Vilnius Gediminas Technical University	2
Engenharia da Construção	Universidad de Burgos	1
Engenharia de Energias Renováveis	Instituto Politécnico de Setúbal	1
	Universidad de La Coruña	1
	Universitatea Stefan cel Mare Suceava	9
	University “Stefan Cel Mare” of Suceava	1
	University of West Attica	3
Engenharia do Ambiente	Instituto Politécnico de Bragança	1
	Warsaw University of Technology	1

Engenharia Eletrotécnica e de Computadores	Instituto Politécnico de Bragança	15
	Josip Juraj Strossmayer University of Osijek – UNIOS	3
	Kaunas Technical College	4
	Koszalin University of Technology	3
	School of Pedagogical and Technological Education	1
	The President Stanislaw Wojciechowski Higher Vocational State School in Kalisz	1
	Universidad de Extremadura	1
Engenharia Industrial	Bialystok University of Technology	1
	Instituto Politécnico de Bragança	5
	The President Stanislaw Wojciechowski Higher Vocational State School in Kalisz	1
	Universitatea Aurel Vlaicu din Arad	2
Engenharia Informática	Cracow University of Technology	2
	Czestochowa University of Technology	5
	Instituto Politécnico de Bragança	31
	Lomza State University of Applied Sciences	5
	Polytechnic of Rijeka	1
	Poznan University of Technology	4
	Romanian-American University	1
	The Witelton State University of Applied Sciences in Legnica	7
Vistula University	1	
Engenharia Mecânica	Aurel Vlaicu University of Arad	2
	Alexander Dubcek University of Trencin	4
	Czestochowa University of Technology	7
	Instituto Politécnico de Bragança	1
	The President Stanislaw Wojciechowski Higher Vocational State School in Kalisz	2
	Universitatea "Dunarea de Jos" Din Galati	1
	Universitatea Aurel Vlaicu din Arad	2

	University of Applied Engineering Sciences	2
Engenharia Química	Alexander Dubcek University of Trencín	1
	Cracow University of Technology	1
	Silesian University of Technology	1
Engenharia Zootécnica	University of Agricultural Sciences and Veterinary Medicine Cluj-Napoca	1
Farmácia	Universidade Federal de Pelotas	1
Gestão das Organizações	Universitatea West Din Timisoara	1
Gestão de Negócios Internacionais (Curso Europeu)	Aurel Vlaicu University of Arad	2
	Beijing Normal University, Zhuhai	3
	Business School PAR	3
	Instituto Politécnico de Bragança	7
	Mendel University in Brno	3
	RRiF University College of Financial Management	1
	Technical University of Applied Science in Wildau	1
	Université Grenoble Alpes	1
	University Babes-Bolyai	3
	Vilnius Gediminas Technical University	1
	Vistula University	1
Gestão de Recursos Florestais	Demola North Portugal - Brigantia EcoPark	1
Gestão e Administração Pública	National University of Political Studies and Public Administration	4
Gestão	Aurel Vlaicu University of Arad	1
	Aurel Vlaicu University of Arad	2
	Bialystok University of Technology	1
	Business School PAR	1
	Comenius University in Bratislava	1
	National School of Political and Administrative Studies	12
	Polytechnic of Rijeka	3
	RRiF University College of Financial Management	3

	The State School of Higher Professional Education in Konin	1
	Universitatea Dunarea de Jos Din Galati	2
Informática de Gestão	Budapest University of Technology and Economics	1
	Instituto Politécnico de Bragança	44
	Universitatea "Dunarea de Jos" Din Galati	1
	Universitatea Dunarea de Jos Din Galati	1
Informática e Comunicações	Instituto Politécnico de Bragança	2
Línguas Estrangeiras: Inglês e Espanhol	BNUZ Beijing Normal University Zhuhai	1
	Instituto Politécnico de Macau	2
	Pedagogical University of Cracow	1
	Silesian University of Technology	1
	Universidade de Vigo	3
Línguas para Relações Internacionais	College of International and Publique Relations Prague	2
	CZ PRAHA20 - University College of International and Public Relations Prague	1
	Ludwigsburg	1
	Nowy Sacz School of Business National Louis University	2
	Pädagogische Hochschule Ludwigsburg	1
	The State School of Higher Professional Education in Konin	1
	Tischner European University	5
	Universidad Autonoma de Baja California	1
	Universidad de León	1
	Universidade de Vigo	1
	Université de Pau et des Pays de l'Adour	2
	University College of International and Public Relations Prague	3
	University of Castilla-La Mancha	2
	Unversidade leon	2
Marketing	International School of Law and Business	1
	University of Economics in Katowice	1
	UNIVERSITY OF HRADEC KRÁLOVÉ	5

	University of Ss. Cyril and Methodius in Trnava	2
	University of Ss. Cyril nad Methodius in Trnava	1
Multimédia	Offenburg University	1
	University of Silesia in Katowice	5
Sistemas de Informação	Instituto Politécnico de Bragança	1
	Poznan University of Technology	2
	Slovak University of Technology in Bratislava	1
Solicitadoria	Instituto Politécnico do Cávado e do Ave	2
Tecnologia Biomédica	Lodz University of Technology	1
	Technical University of Lodz	1
Tecnologia e Gestão Industrial	Instituto Politécnico de Bragança	3
	Universitatea Aurel Vlaicu din Arad	2
	Universitatea Dunarea de Jos Din Galati	1
Tradução	Universidad de Castilla La-Mancha	1
Turismo	Poznan University of Physical Education	2

Table 34: Number of students by course units from each institution in 2019/2020 in General characterization by Course in Mobility(Institution)

Course	Institution	Number
Agroecologia	Instituto Politécnico de Bragança	1
Arte e Design	Demola North Portugal - Brigantia EcoPark	1
Bioanálises e Controlo	IPB	1
Biologia e Biotecnologia	Instituto Politécnico de Bragança	2
Ciências Biomédicas Laboratoriais	IPB	1
Contabilidade	University of Pitesti	1
Design de Jogos Digitais	Instituto Politécnico de Bragança	10
	Kajaani University of Applied Sciences	1
	University of Silesia in Katowice	1
Educação Ambiental	Inovação Baseada em Desafios	2

Enfermagem	Centre Hospitalier Albertville Moutiers	1
Engenharia Agronómica	Instituto Politécnico de Bragança	1
Engenharia Informática	Instituto Politécnico de Bragança	7
	Lublin University of Technology	3
	Polytechnic of Rijeka	3
	The Witelon State University of Applied Sciences in Legnica	3
	Universitatea Dunarea de Jos Din Galati	1
Engenharia Mecânica	Aurel Vlaicu University of Arad	3
	Aurel Vlaicu University of Arad	1
	The President Stanislaw Wojciechowski Higher Vocational State School in Kalisz	5
	UNIVERSIDAD POLITECNICA DE MADRID	1
Engenharia Química	Alexander Dubcek University of Trencín	1
	Cracow University of Technology	1
Gestão de Negócios Internacionais (Curso Europeu)	Aurel Vlaicu University of Arad	2
Gestão e Administração Pública	National University of Political Studies and Public Administration	1
	Poznan University of Economics and Business	1
Gestão	Bialystok University of Technology	6
	Instituto Politécnico de Bragança	1
	National School of Political and Administrative Studies	6
	University of Pitesti	2
Informática de Gestão	Czestochowa University of Technology	1
Informática	The Witelon State University of Applied Sciences in Legnica	1

Table 35: Number of students by year from each country in General characterization by Country in Mobility(Total)

Country	Year	Number
Alemanha	2017/2018	1
	2018/2019	1
Belgium	2018/2019	1
Brasil	2017/2018	2
	2018/2019	3
	2019/2020	1
	2018/2019	5
Bulgaria	2017/2018	5
	2018/2019	8
China	2017/2018	5
	2018/2019	8
	2019/2020	3
Croatia	2016/2017	1
	2017/2018	7
	2018/2019	12
	2019/2020	17
	2020/2021	3
Czech Republic	2016/2017	4
	2017/2018	18
	2018/2019	24
	2019/2020	14
Espanha	2016/2017	18
	2017/2018	1
	2019/2020	3
Finland	2016/2017	6
	2017/2018	5
	2018/2019	2
	2019/2020	3
	2020/2021	1
França	2016/2017	2
	2017/2018	1
	2018/2019	1
	2019/2020	3
	2020/2021	1
Germany	2016/2017	1
	2017/2018	4
	2018/2019	3
	2019/2020	4
Greece	2016/2017	4
	2017/2018	5
	2018/2019	11
	2019/2020	6

Hungary	2016/2017	5
	2017/2018	3
	2018/2019	6
	2019/2020	7
Italy	2018/2019	3
	2019/2020	1
Latvia	2016/2017	1
	2018/2019	2
	2019/2020	2
Lithuania	2016/2017	18
	2017/2018	10
	2018/2019	6
	2019/2020	10
Macau	2018/2019	1
	2019/2020	4
Mexico	2017/2018	4
	2019/2020	1
Netherlands	2017/2018	2
Poland	2016/2017	86
	2017/2018	72
	2018/2019	77
	2019/2020	80
	2020/2021	22
Polónia	2016/2017	1
	2016/2017	2
	2017/2018	1
	2017/2018	2
	2017/2018	6
Portugal	2017/2018	48
	2018/2019	84
	2019/2020	163
	2020/2021	26
Republica Checa	2017/2018	6
Romania	2016/2017	57
	2017/2018	54
	2018/2019	54
	2019/2020	69
	2020/2021	17
Slovakia	2016/2017	8
	2017/2018	12
	2018/2019	10
	2019/2020	10
	2020/2021	1
Slovenia	2016/2017	2
	2017/2018	2
	2018/2019	4

Spain	2016/2017	5
	2017/2018	32
	2018/2019	49
	2019/2020	43
	2020/2021	1
The Netherlands	2018/2019	3
United Kingdom	2016/2017	1

Table 36: Number of students by school from each country, 2016/2017 in General characterization by Country in Mobility(School), 2016/2017

School	Country	Number
ESA	Latvia	1
	Letónia	2
	Poland	3
	Romania	21
EsACT	Finland	6
	Hungary	1
	Lithuania	8
	Poland	6
	Slovenia	1
ESE	Polonia	2
ESSa	Espanha	18
	França	2
	Greece	2
	Poland	3
	Polónia	1
	Spain	3
	United Kingdom	1
ESTiG	Croatia	1
	Czech Republic	4
	Germany	1
	Greece	2
	Hungary	4
	Lithuania	10
	Poland	74
	Romania	36
	Slovakia	8
	Slovenia	1
	Spain	2

Table 37: Number of students by school from each country, 2017/2018 in General characterization by Country in Mobility(School), 2017/2018

School	Country	Number
ESA	Brasil	1
	Poland	6
	Portugal	4
	Romania	16
	Spain	1
EsACT	Czech Republic	3
	Finland	5
	Lithuania	1
	Poland	19
	Portugal	7
	Slovenia	1
ESE	Alemanha	1
	Brasil	1
	China	5
	Croatia	3
	Czech Republic	8
	Espanha	1
	Germany	3
	Itália	1
	Lithuania	1
	Poland	9
	Pólonia	1
	Polónia	2
	Polonia	6
	Portugal	8
	Republica Checa	6
	Romania	1
	Romenia	1
	Roménia	1
Spain	5	
ESSa	France	1
	Greece	2
	Mexico	2
	Portugal	2
	Spain	22

ESTiG	Bulgaria	5
	Croatia	4
	Czech Republic	7
	Germany	1
	Greece	3
	Hungary	3
	Lithuania	8
	Mexico	2
	Netherlands	2
	Poland	38
	Portugal	27
	Romania	37
	Slovakia	12
	Slovenia	1
	Spain	4

Table 38: Number of students by school from each country, 2018/2019 in General characterization by Country in Mobility(School), 2018/2019

School	Country	Number
ESA	Poland	2
	Portugal	6
	Romania	6
	Spain	3
EsACT	Brasil	1
	Czech Republic	1
	Finland	2
	Latvia	2
	Lithuania	3
	Poland	15
	Portugal	3
	Romania	5
	Spain	1
	The Netherlands	3
ESE	Alemanha	1
	Brasil	2
	Brazil	4
	China	8
	Czech Republic	16
	Germany	2
	Poland	17
	Portugal	6
	Romania	6
	Spain	1

ESSa	Belgium	1
	Brazil	1
	Germany	1
	Greece	6
	Italy	2
	Macau	1
	Portugal	2
	Spain	39
ESTiG	Bulgaria	8
	Croatia	12
	Czech Republic	7
	France	1
	Greece	5
	Hungary	6
	Italy	1
	Lithuania	3
	Poland	43
	Portugal	67
	Romania	37
	Slovakia	10
	Slovenia	4
Spain	5	

Table 39: Number of students by school from each country, 2019/2020 in General characterization by Country in Mobility(School), 2019/2020

School	Country	Number
ESA	Latvia	2
	Poland	3
	Portugal	6
	Romania	2
	Roména	1
	Roménia	4
EsACT	Czech Republic	5
	Finland	3
	Germany	1
	Lithuania	1
	Poland	9
	Portugal	37
	Romania	4
	Slovakia	3
ESE	China	1
	Croatia	1

	Czech Republic	6
	Espanha	3
	France	2
	Germany	2
	Hungary	6
	Hungria	1
	Italy	1
	Macau	2
	México	1
	Poland	19
	Portugal	6
	Romania	4
	Spain	7
ESSa	Brasil	1
	Greece	2
	Macau	2
	Spain	31
ESTiG	China	2
	Croat	1
	Croatia	16
	Czech Republic	3
	France	1
	Germany	1
	Greece	4
	Hungary	1
	Lithuania	9
	Poland	49
	Portugal	114
	Romania	59
	Slovakia	7
	Spain	5

Table 40: Number of students by school from each country, 2020/2021 in General characterization by Country in Mobility(School), 2020/2021

School	Country	Number
ESA	Bragança	1
	Portugal	3
EsACT	Finland	1
	Poland	2
	Portugal	10

	Romania	1
ESE	Portugal	3
ESSa	France	1
	Portugal	2
ESTiG	Croatia	3
	Poland	20
	Portugal	8
	Romania	16
	Slovakia	1
	Spain	1

Table 40: Number of students by institution from each country, 2016/2017 in General characterization by Country in Mobility(Institution), 2016/2017

Country	Institution	Number
Croatia	University of Split	1
Czech Republic	Technical University of Ostrava	4
Espanha	Escuela Universitaria de Enfermería de Zamora	14
	Facultad de Ciencias de la Salud - Universidade de Leon	1
	Hospital Virgen de la Concha	2
	Universidade de Sevilha	1
Finland	Kajaani University of Applied Sciences	6
França	Institut de Formation en Soins Infirmiers Virginie Olivier	2
Germany	Technical University of Applied Science in Wildau	1
Greece	Alexander Technological Educational Institution of Tessaloniki	2
	School of Pedagogical and Technological Education	2
Hungary	Obuda University- John Von Neumann Faculty of Informatics	1
	University of Dunaújváros	3
	University of Technology and Economics Budapest	1
Latvia	Latvia University of Agriculture	1
Letónia	Latvia University of Agriculture	2
Lithuania	Kauno Kolegija - University of Applied Sciences	13
	Vilnius Gediminas Technical University	2
	Vilnius College of Technologies and Design	1
	Vilnius Gediminas Technical University	2
Poland	Bialystok University of Technology	5
	Cracow University of Technology	2
	Czestochowa University of Technology	9

	Gdansk School of Banking	3
	Koszalin University of Technology	3
	Lodz University of Technology	4
	Panstwowa Wyzsza Szkola Zawodowa w Koninie	6
	Poznan University of Technology	4
	The President Stanislaw Wojciechowski Higher Vocational State School in Kalisz	32
	University of Ecology and Management in Warsaw	6
	University of Economics and Innovation in Lublin	2
	University of Oradea	1
	University of Warmia and Mazury in Olsztyn	1
	Vistula University	5
	Wroclaw University of Technology	3
Polonia	PL KRAKOW12 - University School of Physical Education	2
	The President Stanislaw Wojciechowski Higher Vocational State School in Kalisz	1
Romania	Aurel Vlaicu University of Arad	2
	Academia de Studii Economice din Bucuresti	3
	Aurel Vlaicu "University of Arad"	3
	National School of Political and Administrative Studies	5
	National University of Political Studies and Public Administration	4
	The "Ion Ionescu de la Brad" University of Agricultural Sciences and Veterinary Medicine of Iasi	16
	Universitatea Aurel Vlaicu din Arad	2
	Universitatea Din Pitesti	5
	Universitatea Polytechnica din Timisoara	3
	Universitatea Stefan cel Mare Suceava	8
	University of Agricultural Sciences and Veterinary Medicine Cluj-Napoca	1
	University of Agricultural Sciences and Veterinary Medicine	2
	University of Oradea	3
Slovakia	Alexander Dubcek University of Trencin	4
	Alexander Ducek University Trencin	2

	Comenius University in Bratislava	2
Slovenia	Alexander Ducek University Trencin	1
	University of Maribor	1
Spain	Escuela Universitaria de Enfermería de Zamora	3
	Universidade da Coruña	2
United Kingdom	Sussex Health Care	1

Table 41: Number of students by institution from each country, 2017/2018 in General characterization by Country in Mobility(Institution), 2017/2018

Country	Institution	Nummber
Alemanha	Ludwigsburg	1
Brasil	Universidade Federal de Goiás	1
	Universidade Federal de Mato Grosso	1
Bulgaria	Konstantin Preslavsky University of Shumen	5
China	Beijing Normal University, Zhuhai	1
	BNUZ Beijing Normal University Zhuhai	4
Croatia	RRiF University College of Financial Management	4
	University of Zagreb	3
Czech Republic	College of International and Publique Relations Prague	3
	CZ PRAHA20 - University College of International and Public Relations Prague	4
	Silesian University in Opava	7
	University College of International and Public Relations Prague	1
	University of Pardubice	3
Espanha	Universidad de Valladolid	1
Finland	Kajaani University of Applied Sciences	5
France	Institut de Formation en Soins Infirmiers Virginie Olivier	1
Germany	Johannes Gutenberg-Universität Mainz	3
	University of Applied Sciences	1

Greece	Harokopio University	2
	TEI Piraeus	3
Hungary	University of Dunaujváros	3
Itália	Universit� Di Bologna	1
Lithuania	Kaunas University of Applied Sciences	5
	Kauno Kolegija - University of Applied Sciences	1
	LT VILNIUS04 - Vilnius Pedagogical University	1
	Vilniaus Gediminas Technical University	1
	Vilnius Gediminas Technical University	2
Mexico	Universidad Autonoma de Baja California	2
	Universidad Aut�noma de Baja California	2
Netherlands	Windesheim University of Applied Sciences	2
Poland	Bialystok University of Technology	3
	Czestochowa University of Technology	6
	Koszalin University of Technology	9
	National School of Political and Administrative Studies	1
	Opole University of Technology	7
	Panstwowa Wyzsza Szkola Zawodowa w Koninie	2
	PL KRAKOW12 - University School of Physical Education	5
	Technical University of Lodz	2
	The President Stanislaw Wojciechowski Higher Vocational State School in Kalisz	8
	Tischner European University	4
	University of Business in Wroclaw	3
	University of Economics and Innovation in Lublin	3
	University of Silesia in Katowice	8
	Vistula University	6
	Wroclaw University of Science and Technology	5
P�lonia	PL KRAKOW12 - University School of Physical Education	1
	PL KRAKOW12 - University School of Physical Education	2
	PL KRAKOW12 - University School of Physical Education	4

	Tischner European University	2
Portugal	Démola Project	4
	Demola	1
	Instituto Politécnico de Bragança	38
	Instituto Politécnico do Cávado e do Ave	1
	Instituto Politécnico do Porto	2
	IPB	2
Republica Checa	CZ PRAHA20 - University College of International and Public Relations Prague	2
	University College of International and Public Relations Prague	1
	UNIVERSITY OF HRADEC KRÁLOVÉ	3
Romania	Koszalin University of Technology	1
	National School of Political and Administrative Studies	9
	The "Ion Ionescu de la Brad" University of Agricultural Sciences and Veterinary Medicine of Iasi	12
	Universitatea "Dunarea de Jos" Din Galati	1
	Universitatea Aurel Vlaicu din Arad	7
	Universitatea Din Pitesti	7
	Universitatea Dunarea de Jos Din Galati	2
	Universitatea Stefan cel Mare Suceava	3
	Universitatea West Din Timisoara	2
	UNIVERSITY "DUNAREA DE JOS" OF GALATI, ROMANIA	1
	University Babes-Bolyai	2
	University of Agricultural Sciences and Veterinary Medicine Cluj-Napoca	4
	University of Oradea	3
	Aurel Vlaicu University of Arad	1
Roménia	Aurel Vlaicu University of Arad	1
Slovakia	Alexander Dubcek University of Trencin	3
	Comenius University in Bratislava	9
	University of Maribor	2
Spain	EOXI DE OURENSE, VENIX E O BARCO DE VALDEORMS	1

	Escuela Universitaria de Enfermería de Zamora	19
	Hospital Virgen de la Concha	1
	Universidad de Huelva	3
	Universidad de Jaen	2
	Universidad de Salamanca	1
	UNIVERSITY OF CASTILLA-LA MANCHA	5

Table 42: Number of students by institution from each country, 2018/2019 in General characterization by Country in Mobility(Institution), 2018/2019

Country	Institution	Number
Alemanha	Pädagogische Hochschule Ludwigsburg	1
Belgium	Thomas More University College	1
Brasil	Instituto Federal de Educação, Ciência e Tecnologia do Sul de Minas Gerais	1
	Universidade Federal de Goiás	1
	Universidade Federal de Pelotas	1
	Instituto Federal de Educação, Ciência e Tecnologia do Sul de Minas Gerais	1
	Universidade Federal de Goiás	2
	Universidade Federal de Pelotas	2
Bulgaria	Konstantin Preslavsky University of Shumen	5
	Varna University of Management	3
China	Beijing Normal University, Zhuhai	5
	BNUZ Beijing Normal University Zhuhai	2
	Instituto Politécnico de Macau	1
Croatia	Polytechnic of Rijeka	7
	University in Rijeka	5
Czech Republic	College of International and Public Relations Prague	16
	Masaryk University in Brno	1
	Masaryk University	1
	Silesian University in Opava	4

	UNIVERSITY OF HRADEC KRÁLOVÉ	2
Finland	Kajaani University of Applied Sciences	1
	Tampere University of Applied Sciences	1
France	Université Grenoble Alpes	1
Germany	Mani Häusliche Pflege	1
	Pädagogische Hochschule Ludwigsburg	2
Greece	Alexander Technological Educational Institution of Tessaloniki	4
	Harokopio University	2
	University of West Attica	5
Hungary	University of Dunaújváros	6
Italy	Politecnico di Bari	1
	Universita' degli Studi del Molise	2
Latvia	University of Latvia	2
Lithuania	Kaunas University of Applied Sciences	3
	SMK University of Applied Social Sciences	3
Macau	Instituto Politécnico de Macau	1
Poland	angelus Silesius University of Applied Sciences in Walbrzych	7
	Bialystok University of Technology	4
	Cracow University of Economics	3
	Cracow University of Technology	3
	Czestochowa University of Technology	6
	Lodz University of Technology	1
	Lomza State University of Applied Sciences	8
	Nowy Sacz School of Business National Louis University	1
	Opole University of Technology	2
	Panstwowa Wyzsza Szkola Zawodowa w Koninie	4
	Pedagogical University of Cracow	3
	PL KRAKOW12 - University School of Physical Education	2
	State University of Applied Sciences in Nowy Sacz	1
	Technical University of Lodz	2

	The President Stanislaw Wojciechowski Higher Vocational State School in Kalisz	4
	The Witelon State University of Applied Sciences in Legnica	7
	University of Business in Wroclaw	3
	University of Ecology and Management in Warsaw	3
	University of Economics in Katowice	2
	University of Silesia in Katowice	10
	University of Warsaw	1
Portugal	Demola North Portugal - Brigantia EcoPark	10
	Demola	1
	Instituto Politécnico de Bragança	71
	Instituto Politécnico de Setúbal	1
	IPB Empreendedorismo e Inovação	1
Romania	National School of Political and Administrative Studies	4
	National University of Political Studies and Public Administration	5
	The "Ion Ionescu de la Brad" University of Agricultural Sciences and Veterinary Medicine of Iasi	6
	Universitatea "Dunarea de Jos" Din Galati	6
	Universitatea Aurel Vlaicu din Arad	8
	Universitatea Dunarea de Jos Din Galati	5
	Universitatea Polytechnica din Timisoara	4
	Universitatea Stefan cel Mare Suceava	6
	Universitatea West Din Timisoara	4
	UNIVERSITY "DUNAREA DE JOS" OF GALATI, ROMANIA	1
	University of Oradea	5
Slovakia	Alexander Dubcek University of Trencin	6
	Comenius University in Bratislava	4
Slovenia	University of Maribor	4
Spain	Escuela Universitaria de Enfermería de Zamora	23
	Hospital Universitario de Ourense	1
	Hospital Virgen de la Concha	9

	Universidad de Almeria	1
	Universidad de Burgos	2
	Universidad de Extremadura	3
	Universidad de Jaen	3
	UNIVERSIDAD POLITECNICA DE MADRID	1
	Universidade de Santiago de Compostela	4
	Universidade de Valladolid	1
	Universidade de Vigo	1
The Netherlands	Hanze University of Applied Sciences	3

Table 43: Number of students by institution from each country, 2019/2020 in General characterization by Country in Mobility(Institution), 2019/2020

Country	Institution	Number
Brasil	Universidade Federal de Pelotas	1
China	Beijing Normal University, Zhuhai	2
	BNUZ Beijing Normal University Zhuhai	1
Croatia	University in Rijeka	2
	Business School PAR	4
	Josip Juraj Strossmayer University of Osijek – UNIOS	3
	Polytechnic of Rijeka	4
	RRiF University College of Financial Management	4
Czech Republic	College of International and Public Relations Prague	2
	CZ PRAHA20 - University College of International and Public Relations Prague	1
	Mendel University in Brno	3
	University College of International and Public Relations Prague	3
	UNIVERSITY OF HRADEC KRÁLOVÉ	5
Espanha	Universidad de León	1
	University of Castilla-La Mancha	2

Finland	Kajaani University of Applied Sciences	3
France	Université de Pau et des Pays de l'Adour	2
	Université Grenoble Alpes	1
Germany	Ludwigsburg	1
	Offenburg University	1
	Pädagogische Hochschule Ludwigsburg	1
	Technical University of Applied Science in Wildau	1
Greece	International Hellenic University	2
	School of Pedagogical and Technological Education	1
	University of West Attica	3
Hungary	Budapest University of Technology and Economics	1
	University of Nyíregyháza	6
Hungria	University of Nyíregyháza	1
Italy	Università Degli Studi Niccolò Cusano	1
Latvia	Latvia University of Life Sciences and Technologies	2
Lithuania	International School of Law and Business	1
	Kaunas Technical College	4
	University of Applied Engineering Sciences	2
	Vilnius Gediminas Technical University	3
Macau	Instituto Politécnico de Macau	4
México	Universidad Autonoma de Baja California	1
Poland	Adam Mickiewicz University	2
	Bialystok University of Technology	4
	Cracow University of Technology	3
	Czestochowa University of Technology	10
	Koszalin University of Technology	3
	Lodz University of Technology	1
	Lomza State University of Applied Sciences	5
	Nowy Sacz School of Business National Louis University	2
	Pedagogical University of Cracow	4

	PL KRAKOW12 - University School of Physical Education	6
	Poznan University of Physical Education	2
	Poznan University of Technology	6
	Silesian University of Technology	2
	Technical University of Lodz	1
	The President Stanislaw Wojciechowski Higher Vocational State School in Kalisz	5
	The State School of Higher Professional Education in Konin	2
	The Witelon State University of Applied Sciences in Legnica	7
	Tischner European University	5
	University of Economics in Katowice	1
	University of Silesia in Katowice	6
	Vistula University	2
	Warsaw University of Technology	1
Portugal	Beijing Normal University, Zhuhai	1
	Czestochowa University of Technology	2
	Demola North Portugal - Brigantia EcoPark	6
	Instituto Politécnico de Bragança	149
	Instituto Politécnico de Setúbal	1
	Instituto Politécnico do Cávado e do Ave	2
	IPB Empreendedorismo e Inovação	1
	Plano Desenvolvimento de Carreiras	1
Romania	Aurel Vlaicu University of Arad	3
	Aurel Vlaicu University of Arad	4
	National School of Political and Administrative Studies	15
	National University of Political Studies and Public Administration	4
	Romanian-American University	1
	The "Ion Ionescu de la Brad" University of Agricultural Sciences and Veterinary Medicine of Iasi	1
	Universitatea "Dunarea de Jos" Din Galati	3
	Universitatea Aurel Vlaicu din Arad	6

	Universitatea Dunarea de Jos Din Galati	4
	Universitatea Stefan cel Mare Suceava	10
	Universitatea West Din Timisoara	7
	UNIVERSITY "DUNAREA DE JOS" OF GALATI, ROMANIA	1
	University "Stefan Cel Mare" of Suceava	1
	University Babes-Bolyai	3
	University of Agricultural Sciences and Veterinary Medicine Cluj-Napoca	1
	University of Oradea	2
	University of Pitesti	3
Roména	University of Agricultural Sciences and Veterinary Medicine Cluj-Napoca	1
Roména	The "Ion Ionescu de la Brad" University of Agricultural Sciences and Veterinary Medicine of Iasi	3
	University of Agricultural Sciences and Veterinary Medicine Cluj-Napoca	1
Slovakia	Alexander Dubcek University of Trencín	1
	Alexander Dubcek University of Trencin	4
	Comenius University in Bratislava	1
	Slovak University of Technology in Bratislava	1
	University of Ss. Cyril and Methodius in Trnava	2
	University of Ss. Cyril nad Methodius in Trnava	1
Spain	Escuela Universitaria de Enfermería de Zamora	15
	Facultad de Enfermería- Universidad de Huelva	3
	Hospital Virgen de la Concha	9
	Universidad de Almeria	3
	Universidad de Burgos	2
	Universidad de Castilla La-Mancha	1
	Universidad de Extremadura	1
	Universidad de La Coruña	2
	Universidade de Santiago de Compostela	1
	Universidade de Vigo	4
	Unversidade leon	2

Table 44: Number of students by institution from each country, 2019/2020 in General characterization by Country in Mobility(Institution), 2019/2020

Country	Institution	Number
Brasil	Universidade Federal de Pelotas	1
China	Beijing Normal University, Zhuhai	2
	BNUZ Beijing Normal University Zhuhai	1
Croatia	University in Rijeka	2
	Business School PAR	4
	Josip Juraj Strossmayer University of Osijek – UNIOS	3
	Polytechnic of Rijeka	4
	RRiF University College of Financial Management	4
Czech Republic	College of International and Publique Relations Prague	2
	CZ PRAHA20 - University College of International and Public Relations Prague	1
	Mendel University in Brno	3
	University College of International and Public Relations Prague	3
	UNIVERSITY OF HRADEC KRÁLOVÉ	5
Espanha	Universidad de León	1
	University of Castilla-La Mancha	2
Finland	Kajaani University of Applied Sciences	3
France	Université de Pau et des Pays de l'Adour	2
	Université Grenoble Alpes	1
Germany	Ludwigsburg	1
	Offenburg University	1
	Pädagogische Hochschule Ludwigsburg	1
	Technical University of Applied Science in Wildau	1
Greece	International Hellenic University	2
	School of Pedagogical and Technological Education	1
	University of West Attica	3

Hungary	Budapest University of Technology and Economics	1
	University of Nyíregyháza	6
Hungria	University of Nyíregyháza	1
Italy	Università Degli Studi Niccolò Cusano	1
Latvia	Latvia University of Life Sciences and Technologies	2
Lithuania	International School of Law and Business	1
	Kaunas Technical College	4
	University of Applied Engineering Sciences	2
	Vilnius Gediminas Technical University	3
Macau	Instituto Politécnico de Macau	4
México	Universidad Autonoma de Baja California	1
Poland	Adam Mickiewicz University	2
	Bialystok University of Technology	4
	Cracow University of Technology	3
	Czestochowa University of Technology	10
	Koszalin University of Technology	3
	Lodz University of Technology	1
	Lomza State University of Applied Sciences	5
	Nowy Sacz School of Business National Louis University	2
	Pedagogical University of Cracow	4
	PL KRAKOW12 - University School of Physical Education	6
	Poznan University of Physical Education	2
	Poznan University of Technology	6
	Silesian University of Technology	2
	Technical University of Lodz	1
	The President Stanislaw Wojciechowski Higher Vocational State School in Kalisz	5
	The State School of Higher Professional Education in Konin	2
	The Witelon State University of Applied Sciences in Legnica	7
Tischner European University	5	
University of Economics in Katowice	1	

	University of Silesia in Katowice	6	
	Vistula University	2	
	Warsaw University of Technology	1	
Portugal	Beijing Normal University, Zhuhai	1	
	Czestochowa University of Technology	2	
	Demola North Portugal - Brigantia EcoPark	6	
	Instituto Politécnico de Bragança	149	
	Instituto Politécnico de Setúbal	1	
	Instituto Politécnico do Cávado e do Ave	2	
	IPB Empreendedorismo e Inovação	1	
	Plano Desenvolvimento de Carreiras	1	
	Romania	Aurel Vlaicu University of Arad	3
		Aurel Vlaicu University of Arad	4
National School of Political and Administrative Studies		15	
National University of Political Studies and Public Administration		4	
Romanian-American University		1	
The "Ion Ionescu de la Brad" University of Agricultural Sciences and Veterinary Medicine of Iasi		1	
Universitatea "Dunarea de Jos" Din Galati		3	
Universitatea Aurel Vlaicu din Arad		6	
Universitatea Dunarea de Jos Din Galati		4	
Universitatea Stefan cel Mare Suceava		10	
Universitatea West Din Timisoara		7	
UNIVERSITY "DUNAREA DE JOS" OF GALATI, ROMANIA		1	
University "Stefan Cel Mare" of Suceava		1	
University Babes-Bolyai		3	
University of Agricultural Sciences and Veterinary Medicine Cluj-Napoca		1	
University of Oradea	2		
University of Pitesti	3		
Roména	University of Agricultural Sciences and Veterinary Medicine Cluj-Napoca	1	

Roménia	The “Ion Ionescu de la Brad” University of Agricultural Sciences and Veterinary Medicine of Iasi	3
	University of Agricultural Sciences and Veterinary Medicine Cluj-Napoca	1
Slovakia	Alexander Dubcek University of Trencín	1
	Alexander Dubcek University of Trencin	4
	Comenius University in Bratislava	1
	Slovak University of Technology in Bratislava	1
	University of Ss. Cyril and Methodius in Trnava	2
	University of Ss. Cyril nad Methodius in Trnava	1
Spain	Escuela Universitaria de Enfermería de Zamora	15
	Facultad de Enfermería- Universidad de Huelva	3
	Hospital Virgen de la Concha	9
	Universidad de Almeria	3
	Universidad de Burgos	2
	Universidad de Castilla La-Mancha	1
	Universidad de Extremadura	1
	Universidad de La Coruña	2
	Universidade de Santiago de Compostela	1
	Universidade de Vigo	4
	Unversidade leon	2

Table 45: Number of students by institution from each country, 2020/2021 in General characterization by Country in Mobility(Institution), 2020/2021

Country	Institution	Number
Croatia	Polytechnic of Rijeka	3
Finland	Kajaani University of Applied Sciences	1
France	Centre Hospitalier Albertville Moutiers	1
Poland	Bialystok University of Technology	6
	Cracow University of Technology	1

	Czestochowa University of Technology	1
	Lublin University of Technology	3
	Poznan University of Economics and Business	1
	The President Stanislaw Wojciechowski Higher Vocational State School in Kalisz	5
	The Witelon State University of Applied Sciences in Legnica	4
	University of Silesia in Katowice	1
Portugal	Demola North Portugal - Brigantia EcoPark	1
	Inovação Baseada em Desafios	2
	Instituto Politécnico de Bragança	21
	IPB	2
Romania	Aurel Vlaicu University of Arad	3
	Aurel Vlaicu University of Arad	3
	National School of Political and Administrative Studies	6
	National University of Political Studies and Public Administration	1
	Universitatea Dunarea de Jos Din Galati	1
	University of Pitesti	3
Slovakia	Alexander Dubcek University of Trencín	1
Spain	UNIVERSIDAD POLITECNICA DE MADRID	1

Table 46: Number of students by year from each institution in General characterization by Institution in Mobility

Year	Institution	Number
2016/2017	Aurel Vlaicu University of Arad	2
	Academia de Studii Economice din Bucuresti	3
	Alexander Dubcek University of Trencin	4
	Alexander Ducek University Trencin	3

Alexander Technological Educational Institution of Tessaloniki	2
Aurel Vlaicu "University of Arad"	3
Bialystok University of Technology	5
Comenius University in Bratislava	2
Cracow University of Technology	2
Czestochowa University of Technology	9
Escuela Universitaria de Enfermería de Zamora	17
Facultad de Ciencias de la Salud - Universidade de Leon	1
Gdansk School of Banking	3
Hospital Virgen de la Concha	2
Institut de Formation en Soins Infirmiers Virginie Olivier	2
Kajaani University of Applied Sciences	6
Kauno Kolegija - University of Applied Sciences	13
Koszalin University of Technology	3
Latvia University of Agriculture	3
Lodz University of Technology	4
National School of Political and Administrative Studies	5
National University of Political Studies and Public Administration	4
Obuda University- John Von Neumann Faculty of Informatics	1
Panstwowa Wyzsza Szkola Zawodowa w Koninie	6
PL KRAKOW12 - University School of Physical Education	2
Poznan University of Technology	4
School of Pedagogical and Technological Education	2
Sussex Health Care	1
Technical University of Applied Science in Wildau	1
Technical University of Ostrava	4
The "Ion Ionescu de la Brad" University of Agricultural Sciences and Veterinary Medicine of Iasi	16
The President Stanislaw Wojciechowski Higher Vocational State School in Kalisz	33
Universidade da Coruña	2

	Universidade de Sevilha	1
	Universitatea Aurel Vlaicu din Arad	2
	Universitatea Din Pitesti	5
	Universitatea Polytechnica din Timisoara	3
	Universitatea Stefan cel Mare Suceava	8
	University of Agricultural Sciences and Veterinary Medicine Cluj-Napoca	1
	University of Agricultural Sciences and Veterinary Medicine	2
	University of Dunaújváros	3
	University of Ecology and Management in Warsaw	6
	University of Economics and Innovation in Lublin	2
	University of Maribor	1
	University of Oradea	4
	University of Split	1
	University of Technology and Economics Budapest	1
	University of Warmia and Mazury in Olsztyn	1
	Vilniaus Gediminas Technical University	2
	Vilnius College of Technologies and Design	1
	Vilnius Gediminas Technical University	2
	Vistula University	5
	Wroclaw University of Technology	3
2017/2018	Aurel Vlaicu University of Arad	2
	Alexander Dubcek University of Trencin	3
	Beijing Normal University, Zhuhai	1
	Bialystok University of Technology	3
	BNUZ Beijing Normal University Zhuhai	4
	College of International and Publique Relations Prague	3
	Comenius University in Bratislava	9
	CZ PRAHA20 - University College of International and Public Relations Prague	6
	Czestochowa University of Technology	6
	Démola Project	4

Demola	1
EOXI DE OURENSE, VENIX E O BARCO DE VALDEORMS	1
Escuela Universitaria de Enfermería de Zamora	19
Harokopio University	2
Hospital Virgen de la Concha	1
Institut de Formation en Soins Infirmiers Virginie Olivier	1
Instituto Politécnico de Bragança	38
Instituto Politécnico do Cávado e do Ave	1
Instituto Politécnico do Porto	2
IPB	2
Johannes Gutenberg-Universität Mainz	3
Kajaani University of Applied Sciences	5
Kaunas University of Applied Sciences	5
Kauno Kolegija - University of Applied Sciences	1
Konstantin Preslavsky University of Shumen	5
Koszalin University of Technology	10
LT VILNIUS04 - Vilnius Pedagogical University	1
Ludwigsburg	1
National School of Political and Administrative Studies	10
Opole University of Technology	7
Panstwowa Wyzsza Szkola Zawodowa w Koninie	2
PL KRAKOW12 - University School of Physical Education	12
RRiF University College of Financial Management	4
Silesian University in Opava	7
Technical University of Lodz	2
TEI Piraeus	3
The "Ion Ionescu de la Brad" University of Agricultural Sciences and Veterinary Medicine of Iasi	12
The President Stanislaw Wojciechowski Higher Vocational State School in Kalisz	8
Tischner European University	6

Universidad Autonoma de Baja California	2
Universidad Autónoma de Baja California	2
Universidad de Huelva	3
Universidad de Jaen	2
Universidad de Salamanca	1
Universidad de Valladolid	1
Universidade Federal de Goiás	1
Universidade Federal de Mato Grosso	1
Università Di Bologna	1
Universitatea "Dunarea de Jos" Din Galati	1
Universitatea Aurel Vlaicu din Arad	7
Universitatea Din Pitesti	7
Universitatea Dunarea de Jos Din Galati	2
Universitatea Stefan cel Mare Suceava	3
Universitatea West Din Timisoara	2
UNIVERSITY "DUNAREA DE JOS" OF GALATI, ROMANIA	1
University Babes-Bolyai	2
University College of International and Public Relations Prague	2
University of Agricultural Sciences and Veterinary Medicine Cluj-Napoca	4
University of Applied Sciences	1
University of Business in Wroclaw	3
UNIVERSITY OF CASTILLA-LA MANCHA	5
University of Dunaújváros	3
University of Economics and Innovation in Lublin	3
UNIVERSITY OF HRADEC KRÁLOVÉ	3
University of Maribor	2
University of Oradea	3
University of Pardubice	3
University of Silesia in Katowice	8
University of Zagreb	3

	Vilniaus Gediminas Technical University	1
	Vilnius Gediminas Technical University	2
	Vistula University	6
	Windesheim University of Applied Sciences	2
	Wroclaw University of Science and Technology	5
2018/2019	Alexander Dubcek University of Trencin	6
	Alexander Technological Educational Institution of Tessaloniki	4
	angelus Silesius University of Applied Sciences in Walbrzych	7
	Beijing Normal University, Zhuhai	5
	Bialystok University of Technology	4
	BNUZ Beijing Normal University Zhuhai	2
	College of International and Publique Relations Prague	16
	Comenius University in Bratislava	4
	Cracow University of Economics	3
	Cracow University of Technology	3
	Czestochowa University of Technology	6
	Demola North Portugal - Brigantia EcoPark	10
	Demola	1
	Escuela Universitaria de Enfermería de Zamora	23
	Hanze University of Applied Sciences	3
	Harokopio University	2
	Hospital Universitario de Ourense	1
	Hospital Virgen de la Concha	9
	Instituto Federal de Educação, Ciência e Tecnologia do Sul de Minas Gerais	2
	Instituto Politécnico de Bragança	71
	Instituto Politécnico de Macau	2
	Instituto Politécnico de Setúbal	1
	IPB Empreendedorismo e Inovação	1
	Kajaani University of Applied Sciences	1
	Kaunas University of Applied Sciences	3

Konstantin Preslavsky University of Shumen	5
Lodz University of Technology	1
Lomza State University of Applied Sciences	8
Mani Häusliche Pflege	1
Masaryk University in Brno	1
Masaryk University	1
National School of Political and Administrative Studies	4
National University of Political Studies and Public Administration	5
Nowy Sacz School of Business National Louis University	1
Opole University of Technology	2
Pädagogische Hochschule Ludwigsburg	3
Panstwowa Wyzsza Szkola Zawodowa w Koninie	4
Pedagogical University of Cracow	3
PL KRAKOW12 - University School of Physical Education	2
Politecnico di Bari	1
Polytechnic of Rijeka	7
Silesian University in Opava	4
SMK University of Applied Social Sciences	3
State University of Applied Sciences in Nowy Sacz	1
Tampere University of Applied Sciences	1
Technical University of Lodz	2
The "Ion Ionescu de la Brad" University of Agricultural Sciences and Veterinary Medicine of Iasi	6
The President Stanislaw Wojciechowski Higher Vocational State School in Kalisz	4
The Witelton State University of Applied Sciences in Legnica	7
Thomas More University College	1
Universidad de Almeria	1
Universidad de Burgos	2
Universidad de Extremadura	3
Universidad de Jaen	3

	UNIVERSIDAD POLITECNICA DE MADRID	1
	Universidade de Santiago de Compostela	4
	Universidade de Valladolid	1
	Universidade de Vigo	1
	Universidade Federal de Goiás	3
	Universidade Federal de Pelotas	3
	Universita' degli Studi del Molise	2
	Universitatea "Dunarea de Jos" Din Galati	6
	Universitatea Aurel Vlaicu din Arad	8
	Universitatea Dunarea de Jos Din Galati	5
	Universitatea Polytechnica din Timisoara	4
	Universitatea Stefan cel Mare Suceava	6
	Universitatea West Din Timisoara	4
	Université Grenoble Alpes	1
	UNIVERSITY "DUNAREA DE JOS" OF GALATI, ROMANIA	1
	University in Rijeka	5
	University of Business in Wroclaw	3
	University of Dunaújváros	6
	University of Ecology and Management in Warsaw	3
	University of Economics in Katowice	2
	UNIVERSITY OF HRADEC KRÁLOVÉ	2
	University of Latvia	2
	University of Maribor	4
	University of Oradea	5
	University of Silesia in Katowice	10
	University of Warsaw	1
	University of West Attica	5
	Varna University of Management	3
2019/2020	Aurel Vlaicu University of Arad	3
	Adam Mickiewicz University	2

Alexander Dubcek University of Trencin	1
Alexander Dubcek University of Trencin	4
Aurel Vlaicu University of Arad	4
Beijing Normal University, Zhuhai	3
Bialystok University of Technology	4
BNUZ Beijing Normal University Zhuhai	1
Budapest University of Technology and Economics	1
Business School PAR	4
College of International and Publique Relations Prague	2
Comenius University in Bratislava	1
Cracow University of Technology	3
CZ PRAHA20 - University College of International and Public Relations Prague	1
Czestochowa University of Technology	12
Demola North Portugal - Brigantia EcoPark	6
Escuela Universitaria de Enfermería de Zamora	15
Facultad de Enfermería- Universidad de Huelva	3
Hospital Virgen de la Concha	9
Instituto Politécnico de Bragança	149
Instituto Politécnico de Macau	4
Instituto Politécnico de Setúbal	1
Instituto Politécnico do Cávado e do Ave	2
International Hellenic University	2
International School of Law and Business	1
IPB Empreendedorismo e Inovação	1
Josip Juraj Strossmayer University of Osijek – UNIOS	3
Kajaani University of Applied Sciences	3
Kaunas Technical College	4
Koszalin University of Technology	3
Latvia University of Life Sciences and Technologies	2
Lodz University of Technology	1

Lomza State University of Applied Sciences	5
Ludwigsburg	1
Mendel University in Brno	3
National School of Political and Administrative Studies	15
National University of Political Studies and Public Administration	4
Nowy Sacz School of Business National Louis University	2
Offenburg University	1
Pädagogische Hochschule Ludwigsburg	1
Pedagogical University of Cracow	4
PL KRAKOW12 - University School of Physical Education	6
Plano Desenvolvimento de Carreiras	1
Polytechnic of Rijeka	4
Poznan University of Physical Education	2
Poznan University of Technology	6
Romanian-American University	1
RRiF University College of Financial Management	4
School of Pedagogical and Technological Education	1
Silesian University of Technology	2
Slovak University of Technology in Bratislava	1
Technical University of Applied Science in Wildau	1
Technical University of Lodz	1
The "Ion Ionescu de la Brad" University of Agricultural Sciences and Veterinary Medicine of Iasi	4
The President Stanislaw Wojciechowski Higher Vocational State School in Kalisz	5
The State School of Higher Professional Education in Konin	2
The Witelon State University of Applied Sciences in Legnica	7
Tischner European University	5
Universidad Autonoma de Baja California	1
Universidad de Almeria	3
Universidad de Burgos	2

Universidad de Castilla La-Mancha	1
Universidad de Extremadura	1
Universidad de La Coruña	2
Universidad de León	1
Universidade de Santiago de Compostela	1
Universidade de Vigo	4
Universidade Federal de Pelotas	1
Università Degli Studi Niccolò Cusano	1
Universitatea "Dunarea de Jos" Din Galati	3
Universitatea Aurel Vlaicu din Arad	6
Universitatea Dunarea de Jos Din Galati	4
Universitatea Stefan cel Mare Suceava	10
Universitatea West Din Timisoara	7
Université de Pau et des Pays de l'Adour	2
Université Grenoble Alpes	1
UNIVERSITY "DUNAREA DE JOS" OF GALATI, ROMANIA	1
University "Stefan Cel Mare" of Suceava	1
University Babes-Bolyai	3
University College of International and Public Relations Prague	3
University in Rijeka	3
University of Agricultural Sciences and Veterinary Medicine Cluj-Napoca	3
University of Applied Engineering Sciences	2
University of Castilla-La Mancha	2
University of Economics in Katowice	1
UNIVERSITY OF HRADEC KRÁLOVÉ	5
University of Nyíregyháza	7
University of Oradea	2
University of Pitesti	3
University of Silesia in Katowice	6
University of Ss. Cyril and Methodius in Trnava	2

	University of Ss. Cyril nad Methodius in Trnava	1
	University of West Attica	3
	Unversidade leon	2
	Vilnius Gediminas Technical University	3
	Vistula University	2
	Warsaw University of Technology	1
2020/2021	Aurel Vlaicu University of Arad	3
	Alexander Dubcek University of Trencín	1
	Aurel Vlaicu University of Arad	3
	Bialystok University of Technology	6
	Centre Hospitalier Albertville Moutiers	1
	Cracow University of Technology	1
	Czestochowa University of Technology	1
	Demola North Portugal - Brigantia EcoPark	1
	Inovação Baseada em Desafios	2
	Instituto Politécnico de Bragança	22
	IPB	2
	Kajaani University of Applied Sciences	1
	Lublin University of Technology	3
	National School of Political and Administrative Studies	6
	National University of Political Studies and Public Administration	1
	Polytechnic of Rijeka	3
	Poznan University of Economics and Business	1
	The President Stanislaw Wojciechowski Higher Vocational State School in Kalisz	5
	The Witelon State University of Applied Sciences in Legnica	4
	UNIVERSIDAD POLITECNICA DE MADRID	1
	Universitatea Dunarea de Jos Din Galati	1
	University of Pitesti	3
University of Silesia in Katowice	1	

Table 47: Number of students by school from each institution, 2016/2017 in General characterization by Institution in Mobility(School), 2016/2017

School	Institution	Number
ESA	Bialystok University of Technology	3
	Latvia University of Agriculture	3
	The "Ion Ionescu de la Brad" University of Agricultural Sciences and Veterinary Medicine of Iasi	16
	Universitatea Aurel Vlaicu din Arad	2
	University of Agricultural Sciences and Veterinary Medicine Cluj-Napoca	1
	University of Agricultural Sciences and Veterinary Medicine	2
EsACT	Kajaani University of Applied Sciences	6
	Kauno Kolegija - University of Applied Sciences	8
	Obuda University- John Von Neumann Faculty of Informatics	1
	Panstwowa Wyzsza Szkola Zawodowa w Koninie	2
	University of Maribor	1
	Vistula University	4
ESE	PL KRAKOW12 - University School of Physical Education	2
ESSa	Alexander Technological Educational Institution of Tessaloniki	2
	Escuela Universitaria de Enfermería de Zamora	17
	Facultad de Ciencias de la Salud - Universidade de Leon	1
	Hospital Virgen de la Concha	2
	Institut de Formation en Soins Infirmiers Virginie Olivier	2
	Sussex Health Care	1
	The President Stanislaw Wojciechowski Higher Vocational State School in Kalisz	4
	Universidade de Sevilha	1
ESTiG	Aurel Vlaicu University of Arad	2
	Academia de Studii Economice din Bucuresti	3

Alexander Dubcek University of Trencin	4
Alexander Ducek University Trencin	3
Aurel Vlaicu "University of Arad"	3
Bialystok University of Technology	2
Comenius University in Bratislava	2
Cracow University of Technology	2
Czestochowa University of Technology	9
Gdansk School of Banking	3
Kauno Kolegija - University of Applied Sciences	5
Koszalin University of Technology	3
Lodz University of Technology	4
National School of Political and Administrative Studies	5
National University of Political Studies and Public Administration	4
Panstwowa Wyzsza Szkola Zawodowa w Koninie	4
Poznan University of Technology	4
School of Pedagogical and Technological Education	2
Technical University of Applied Science in Wildau	1
Technical University of Ostrava	4
The President Stanislaw Wojciechowski Higher Vocational State School in Kalisz	29
Universidade da Coruña	2
Universitatea Din Pitesti	5
Universitatea Polytechnica din Timisoara	3
Universitatea Stefan cel Mare Suceava	8
University of Dunaújváros	3
University of Ecology and Management in Warsaw	6
University of Economics and Innovation in Lublin	2
University of Oradea	4
University of Split	1
University of Technology and Economics Budapest	1
University of Warmia and Mazury in Olsztyn	1

	Vilnius Gediminas Technical University	2
	Vilnius College of Technologies and Design	1
	Vilnius Gediminas Technical University	2
	Vistula University	1
	Wroclaw University of Technology	3

Table 48: Number of students by school from each institution, 2017/2018 in General characterization by Institution in Mobility(School), 2017/2018

School	Institution	Number
ESA	Bialystok University of Technology	1
	Instituto Politécnico de Bragança	4
	Opole University of Technology	5
	The "Ion Ionescu de la Brad" University of Agricultural Sciences and Veterinary Medicine of Iasi	12
	Universidad de Jaen	1
	Universidade Federal de Mato Grosso	1
	University of Agricultural Sciences and Veterinary Medicine Cluj-Napoca	4
EsACT	Bialystok University of Technology	2
	Instituto Politécnico de Bragança	7
	Kajaani University of Applied Sciences	5
	Kauno Kolegija - University of Applied Sciences	1
	Silesian University in Opava	2
	University of Business in Wroclaw	3
	University of Maribor	1
	University of Pardubice	1
	University of Silesia in Katowice	8
	Vistula University	6
ESE	Aurel Vlaicu University of Arad	2
	Beijing Normal University, Zhuhai	1
	BNUZ Beijing Normal University Zhuhai	4

	College of International and Publique Relations Prague	3
	CZ PRAHA20 - University College of International and Public Relations Prague	6
	Démola Project	4
	Demola	1
	Instituto Politécnico do Cávado e do Ave	1
	Instituto Politécnico do Porto	2
	Johannes Gutenberg-Universität Mainz	3
	LT VILNIUS04 - Vilnius Pedagogical University	1
	Ludwigsburg	1
	PL KRAKOW12 - University School of Physical Education	12
	Tischner European University	6
	Universidad de Valladolid	1
	Universidade Federal de Goiás	1
	Università Di Bologna	1
	UNIVERSITY "DUNAREA DE JOS" OF GALATI, ROMANIA	1
	University College of International and Public Relations Prague	2
	UNIVERSITY OF CASTILLA-LA MANCHA	5
	UNIVERSITY OF HRADEC KRÁLOVÉ	3
	University of Zagreb	3
ESSa	EOXI DE OURENSE, VENIX E O BARCO DE VALDEORMS	1
	Escuela Universitaria de Enfermería de Zamora	19
	Harokopio University	2
	Hospital Virgen de la Concha	1
	Institut de Formation en Soins Infirmiers Virginie Olivier	1
	IPB	2
	Universidad Autonoma de Baja California	2
	Universidad de Salamanca	1
ESTiG	Alexander Dubcek University of Trencin	3
	Comenius University in Bratislava	9
	Czestochowa University of Technology	6

Instituto Politécnico de Bragança	27
Kaunas University of Applied Sciences	5
Konstantin Preslavsky University of Shumen	5
Koszalin University of Technology	10
National School of Political and Administrative Studies	10
Opole University of Technology	2
Panstwowa Wyzsza Szkola Zawodowa w Koninie	2
RRiF University College of Financial Management	4
Silesian University in Opava	5
Technical University of Lodz	2
TEI Piraeus	3
The President Stanislaw Wojciechowski Higher Vocational State School in Kalisz	8
Universidad Autónoma de Baja California	2
Universidad de Huelva	3
Universidad de Jaen	1
Universitatea "Dunarea de Jos" Din Galati	1
Universitatea Aurel Vlaicu din Arad	7
Universitatea Din Pitesti	7
Universitatea Dunarea de Jos Din Galati	2
Universitatea Stefan cel Mare Suceava	3
Universitatea West Din Timisoara	2
University Babes-Bolyai	2
University of Applied Sciences	1
University of Dunaújváros	3
University of Economics and Innovation in Lublin	3
University of Maribor	1
University of Oradea	3
University of Pardubice	2
Vilniaus Gediminas Technical University	1
Vilnius Gediminas Technical University	2

	Windesheim University of Applied Sciences	2
	Wroclaw University of Science and Technology	5

Table 49: Number of students by school from each institution, 2018/2019 in General characterization by Institution in Mobility(School), 2018/2019

School	Institution	Number
ESA	Demola North Portugal - Brigantia EcoPark	5
	IPB Empreendedorismo e Inovação	1
	Opole University of Technology	2
	The "Ion Ionescu de la Brad" University of Agricultural Sciences and Veterinary Medicine of Iasi	6
	Universidad de Jaen	2
	UNIVERSIDAD POLITECNICA DE MADRID	1
EsACT	Hanze University of Applied Sciences	3
	Instituto Federal de Educação, Ciência e Tecnologia do Sul de Minas Gerais	1
	Instituto Politécnico de Bragança	3
	Kajaani University of Applied Sciences	1
	Masaryk University	1
	National University of Political Studies and Public Administration	5
	SMK University of Applied Social Sciences	3
	Tampere University of Applied Sciences	1
	Universidade de Valladolid	1
	University of Business in Wroclaw	3
	University of Economics in Katowice	2
	University of Latvia	2
	University of Silesia in Katowice	10
ESE	angelus Silesius University of Applied Sciences in Walbrzych	7
	Beijing Normal University, Zhuhai	5
	BNUZ Beijing Normal University Zhuhai	2
	College of International and Public Relations Prague	16
	Demola North Portugal - Brigantia EcoPark	5

	Demola	1
	Instituto Federal de Educação, Ciência e Tecnologia do Sul de Minas Gerais	1
	Instituto Politécnico de Macau	1
	Lomza State University of Applied Sciences	3
	Nowy Sacz School of Business National Louis University	1
	Pädagogische Hochschule Ludwigsburg	3
	Pedagogical University of Cracow	3
	PL KRAKOW12 - University School of Physical Education	2
	State University of Applied Sciences in Nowy Sacz	1
	Universidade de Santiago de Compostela	1
	Universidade Federal de Goiás	2
	Universidade Federal de Pelotas	3
	Universitatea "Dunarea de Jos" Din Galati	5
	UNIVERSITY "DUNAREA DE JOS" OF GALATI, ROMANIA	1
ESSa	Alexander Technological Educational Institution of Tessaloniki	4
	Escuela Universitaria de Enfermería de Zamora	23
	Harokopio University	2
	Hospital Universitario de Ourense	1
	Hospital Virgen de la Concha	9
	Instituto Politécnico de Bragança	2
	Instituto Politécnico de Macau	1
	Mani Häusliche Pflege	1
	Thomas More University College	1
	Universidad de Extremadura	3
	Universidade de Santiago de Compostela	3
	Universidade Federal de Goiás	1
	Universita' degli Studi del Molise	2
ESTiG	Alexander Dubcek University of Trencin	6
	Bialystok University of Technology	4
	Comenius University in Bratislava	4

Cracow University of Economics	3
Cracow University of Technology	3
Czestochowa University of Technology	6
Instituto Politécnico de Bragança	66
Instituto Politécnico de Setúbal	1
Kaunas University of Applied Sciences	3
Konstantin Preslavsky University of Shumen	5
Lodz University of Technology	1
Lomza State University of Applied Sciences	5
Masaryk University in Brno	1
National School of Political and Administrative Studies	4
Panstwowa Wyzsza Szkola Zawodowa w Koninie	4
Politecnico di Bari	1
Polytechnic of Rijeka	7
Silesian University in Opava	4
Technical University of Lodz	2
The President Stanislaw Wojciechowski Higher Vocational State School in Kalisz	4
The Witelon State University of Applied Sciences in Legnica	7
Universidad de Almeria	1
Universidad de Burgos	2
Universidad de Jaen	1
Universidade de Vigo	1
Universitatea "Dunarea de Jos" Din Galati	1
Universitatea Aurel Vlaicu din Arad	8
Universitatea Dunarea de Jos Din Galati	5
Universitatea Polytechnica din Timisoara	4
Universitatea Stefan cel Mare Suceava	6
Universitatea West Din Timisoara	4
Université Grenoble Alpes	1
University in Rijeka	5

	University of Dunaújváros	6
	University of Ecology and Management in Warsaw	3
	UNIVERSITY OF HRADEC KRÁLOVÉ	2
	University of Maribor	4
	University of Oradea	5
	University of Warsaw	1
	University of West Attica	5
	Varna University of Management	3

Table 50: Number of students by school from each institution, 2019/2020 in General characterization by Institution in Mobility(School), 2019/2020

School	Institution	Number
ESA	Adam Mickiewicz University	2
	Demola North Portugal - Brigantia EcoPark	1
	Instituto Politécnico de Bragança	4
	IPB Empreendedorismo e Inovação	1
	Latvia University of Life Sciences and Technologies	2
	The "Ion Ionescu de la Brad" University of Agricultural Sciences and Veterinary Medicine of Iasi	4
	University of Agricultural Sciences and Veterinary Medicine Cluj-Napoca	3
	Warsaw University of Technology	1
EsACT	Instituto Politécnico de Bragança	35
	Instituto Politécnico do Cávado e do Ave	2
	International School of Law and Business	1
	Kajaani University of Applied Sciences	3
	National University of Political Studies and Public Administration	4
	Offenburg University	1
	Poznan University of Physical Education	2
	University of Economics in Katowice	1
	UNIVERSITY OF HRADEC KRÁLOVÉ	5
	University of Silesia in Katowice	6

	University of Ss. Cyril and Methodius in Trnava	2
	University of Ss. Cyril nad Methodius in Trnava	1
ESE	BNUZ Beijing Normal University Zhuhai	1
	College of International and Publique Relations Prague	2
	CZ PRAHA20 - University College of International and Public Relations Prague	1
	Demola North Portugal - Brigantia EcoPark	5
	Instituto Politécnico de Macau	2
	Ludwigsburg	1
	Nowy Sacz School of Business National Louis University	2
	Pädagogische Hochschule Ludwigsburg	1
	Pedagogical University of Cracow	4
	PL KRAKOW12 - University School of Physical Education	6
	Plano Desenvolvimento de Carreiras	1
	Silesian University of Technology	1
	The State School of Higher Professional Education in Konin	1
	Tischner European University	5
	Universidad Autonoma de Baja California	1
	Universidad de Castilla La-Mancha	1
	Universidad de León	1
	Universidade de Vigo	4
	Università Degli Studi Niccolò Cussano	1
	Universitatea "Dunarea de Jos" Din Galati	1
	Université de Pau et des Pays de l'Adour	2
	UNIVERSITY "DUNAREA DE JOS" OF GALATI, ROMANIA	1
	University College of International and Public Relations Prague	3
	University in Rijeka	1
	University of Castilla-La Mancha	2
	University of Nyíregyháza	7
	University of Oradea	2
	Unversidade leon	2

ESSa	Escuela Universitaria de Enfermería de Zamora	15
	Facultad de Enfermería- Universidad de Huelva	3
	Hospital Virgen de la Concha	9
	Instituto Politécnico de Macau	2
	International Hellenic University	2
	Universidad de Almeria	3
	Universidade de Santiago de Compostela	1
	Universidade Federal de Pelotas	1
ESTiG	Aurel Vlaicu University of Arad	3
	Alexander Dubcek University of Trencín	1
	Alexander Dubcek University of Trencin	4
	Aurel Vlaicu University of Arad	4
	Beijing Normal University, Zhuhai	3
	Bialystok University of Technology	4
	Budapest University of Technology and Economics	1
	Business School PAR	4
	Comenius University in Bratislava	1
	Cracow University of Technology	3
	Czestochowa University of Technology	12
	Instituto Politécnico de Bragança	110
	Instituto Politécnico de Setúbal	1
	Josip Juraj Strossmayer University of Osijek – UNIOS	3
	Kaunas Technical College	4
	Koszalin University of Technology	3
	Lodz University of Technology	1
	Lomza State University of Applied Sciences	5
	Mendel University in Brno	3
	National School of Political and Administrative Studies	15
Polytechnic of Rijeka	4	
Poznan University of Technology	6	

Romanian-American University	1
RRiF University College of Financial Management	4
School of Pedagogical and Technological Education	1
Silesian University of Technology	1
Slovak University of Technology in Bratislava	1
Technical University of Applied Science in Wildau	1
Technical University of Lodz	1
The President Stanislaw Wojciechowski Higher Vocational State School in Kalisz	5
The State School of Higher Professional Education in Konin	1
The Witelon State University of Applied Sciences in Legnica	7
Universidad de Burgos	2
Universidad de Extremadura	1
Universidad de La Coruña	2
Universitatea "Dunarea de Jos" Din Galati	2
Universitatea Aurel Vlaicu din Arad	6
Universitatea Dunarea de Jos Din Galati	4
Universitatea Stefan cel Mare Suceava	10
Universitatea West Din Timisoara	7
Université Grenoble Alpes	1
University "Stefan Cel Mare" of Suceava	1
University Babes-Bolyai	3
University in Rijeka	2
University of Applied Engineering Sciences	2
University of Pitesti	3
University of West Attica	3
Vilnius Gediminas Technical University	3
Vistula University	2

Table 51: Number of students by school from each institution, 2020/2021 in General characterization by Institution in Mobility(School), 2020/2021

School	Institution	Number
ESA	Instituto Politécnico de Bragança	4
EsACT	Instituto Politécnico de Bragança	10
	Kajaani University of Applied Sciences	1
	National University of Political Studies and Public Administration	1
	Poznan University of Economics and Business	1
	University of Silesia in Katowice	1
ESE	Demola North Portugal - Brigantia EcoPark	1
	Inovação Baseada em Desafios	2
ESSa	Centre Hospitalier Albertville Moutiers	1
	IPB	2
ESTiG	Aurel Vlaicu University of Arad	3
	Alexander Dubcek University of Trencín	1
	Aurel Vlaicu University of Arad	3
	Bialystok University of Technology	6
	Cracow University of Technology	1
	Czestochowa University of Technology	1
	Instituto Politécnico de Bragança	8
	Lublin University of Technology	3
	National School of Political and Administrative Studies	6
	Polytechnic of Rijeka	3
	The President Stanislaw Wojciechowski Higher Vocational State School in Kalisz	5
	The Witelon State University of Applied Sciences in Legnica	4

UNIVERSIDAD POLITECNICA DE MADRID	1
Universitatea Dunarea de Jos Din Galati	1
University of Pitesti	3