

AN ARCHITECTURE FOR INTEROPERABILITY AND UBIQUITY OF MEDICAL INFORMATION

Gonçalo R. Plácido, Carlos R. Cunha and Elisabete Paulo Morais

Polytechnic Institute of Bragança - EsACT

Rua João Maria Sarmento Pimentel, Apartado 128, 5370-326 Mirandela, Portugal

ABSTRACT

In critical situations, such as decision making in healthcare, is necessary to have access to all the patient's information, this information must be reliable, and must be accessed in an easy and fast way. These requirements make medical information systems of extreme importance. However in today's molds and with the advent of the Internet and mobile devices, a paradigm shift, from the current isolated systems to interoperable distributed systems, that take advantage of ubiquitous computing, is needed. The present work proposes an architecture that aims to answer the needs of interoperability between heterogeneous systems and the need of ubiquity of medical information systems.

KEYWORDS

Health information, interoperability, ubiquity, SOA, web services.

1. INTRODUCTION

The Portuguese healthcare system is divided into two main areas, primary care, represented by health centers, and differentiated care, represented by hospitals and other healthcare institutions.

Primary care is the primary source of care and the patients should consult them first, except in cases of emergency. This type of care focuses primarily in general care and proximity with the community, routine consults, monitoring and follow up of chronic patients, along the patient's life.

The access to differentiated care is usually performed by the intervention of primary care health professionals or in case of emergency. This type of care is more specialized than those in primary care and they are used when the primary care can't give an adequate response in specific situations like surgery or oncology patients (Portuguese Legislation nº 56/79, 15 of September).

A patient may consult several healthcare institutions, primary or differentiated, along his life, with the creation of medical information in those situations. The healthcare professional, to make an informed decision about what procedures to follow, needs access to that information scattered through the different institutions (Wright, 2008; Orgun, 2006; Li, 2001).

The healthcare professional in a hospital is unable to access the information created in a health center. As a rule a patient starts to take medication by indication of the primary care physician, but when the patient needs to go to a hospital, for whatever reason, the hospital's health professional doesn't know if the patient is on any medication and what is the medication, unless the patient informs him. The reverse also happens, if a patient is submitted to surgery in a hospital, the primary care professional cannot access the information created during the hospitalization nor during surgery, the primary care professional only takes knowledge of what happened when the patient passes him the information in a future consult in the health center.

In emergency situations in which is extremely important that all relevant medical information about the patient, e.g. pathology, medication, preformed surgeries, is available, the information is not available despite the advantages that the ubiquity of information brings, especially in health related areas (Su, 2011; Jen, 2007; Rigby, 2007; Haux, 2006a).

Thinking in a different perspective from the one in use today, where the information is centred in healthcare institutions, along side with the rise of mobile devices (ANACOM, 2010) and the growing in capacity and functionality of does devices, it makes sense to think in utilizing this kind of devices as auxiliaries in provisioning medical care, distribution of medical information and as an extension to todays

systems (Su, 2011; Sneha 2009; Rigby, 2007).

The present work presents an architecture based in services, using web services, to provide interoperability among the different health information systems that exists today, and the use of mobile devices to provide ubiquitous access to the information.

2. STATE OF THE ART

To promote interoperability among heterogeneous health information systems and the inclusion of mobile devices in health care, several approaches have been followed.

A model using service-oriented architecture (SOA) and web services was proposed to promote interoperability among different health information systems. The proposed model possesses two different approaches, a procedural approach and a documental approach. The procedural approach uses web services to promote the integration of applications using specifications such as Simple Object Access Protocol (SOAP), Web services Definition Language (WSDL) and Universal Description, Discovery and Integration (UDDI). The documental approach tries to describe in detail the elements of the exchange of information among the different systems (Mykkanen, 2007).

Service-oriented Architecture for NHIN Decision Support (SANDS) is an architecture based on services to support clinical decision involving services that provide patient data, healthcare information systems and services that make inferences in support to medical information. This architecture contemplates the situation where the medical history of a patient is distributed among different institutions and that to make an inference about a specific situation more than one system has to be consulted (Wright, 2008).

The Total Health Enriching Mobile U-health Service System (THE-MUSS) is a system proposed to the development of ubiquitous solutions to the area of healthcare. The system consists of a Business Process Management System (BPMS), mobile devices, biosensors and a set of primitives defined using web services, this primitives are the base for the development of more complex services. In this system the biosensors communicate with the mobile device using a personal area network (PAN) and the mobile device communicates whit the servers using the appropriate service (Han, 2010).

Su (2011) proposed the MADIP project. This project is based on a multi-agent architecture with the objective of monitoring remote patients. The different agents are: user agent responsible for the user authentication and for presenting the user's information, the resource agent works as an access interface between the user and the information repository, the physician agent is a mobile agent used by the healthcare professional to monitor and access patient information in a ubiquitous manner, the diagnostic agent is able to analyse the patient health data and tries to predict changes in a patient's state, the knowledge-base data server is where the patient's medical and personal information is stored, the external services represent the hardware, mobile devices, telephones and the different services, e.g. e-mail and text messages.

According to Haux (2006b), traditional institution-centered architectures are not adequate and should be replaced to approaches more patient-centered through 'transinstitutional' information system architectures and infrastructures. This vision is the main stream of this paper.

3. PROBLEM DESCRIPTION

The health information systems that are used in Portugal were not designed with the objective of being interoperable (Espanha, 2010).

The benefits of the adoption of health information systems by the health institutions are undeniable (Liu 2010; Raghupathi, 2008; Haux, 2006b). However the medical information is isolated in the various health institutions (Orgun, 2006). This in fact has been the usual approach in the implementation of health information systems (Wright, 2008).

Each health institution has its own health information repository, which rarely is available to other institutions (Espanha, 2010). Despite the advantages the exchange of information provides (Jha 2008; Haux, 2006a).

The current health information systems are oriented to short encounters between the health professional and the patient, and for the treatment of acute situations (Serbanati, 2011).

The absence of interoperability, that is critical and necessary (Orgun, 2006), among the different systems leads to the rambling, redundant, disorganized and inaccessible medical information that affects the quality of care provided and compromises the health of patients (Raghupathi, 2008; Li, 2001).

In the current systems the patient cannot easily access his medical information, although this information belongs to him (Portuguese Legislation nº 48/90, 24 of August).

For a healthcare professional of primary care be informed, that a patient of his was hospitalized, if some medication has been prescribed or if the patient has been submitted to a procedure and the result of that procedure, it has to be the patient to inform him, because the current systems do not interoperate.

The medical information created in a hospital is not accessible from a health center and vice-versa. In a given situation, unless the patient is conscious and can give the information that the health professional needs to preform a knowledgeable and personalized decision on the best course of action at that time, the health professional does not have access to the totality of the patient's medical information.

If in an institution an error by absence of information occurs, depending on the severity, it may be reverted or minimized because the health professional has more resources to his disposal. But if an error by absence of information occurs away from an institution, by a mobile team of the emergency service, where the resources are scarce reverting the problem will be more difficult if not impossible, hence the need for ubiquitous access to patient's health information (Haux, 2006b).

For the implementation of the prototype of the proposed architecture (Figure 2) a data model (Figure 1) was created that tries to represent a part of the relevant medical information of a patient, this model will be placed in the subsystem GLOBAL (Figure 2) and will be the repository of all information in the proposed architecture. Also functioning as a security copy of the patient's information.

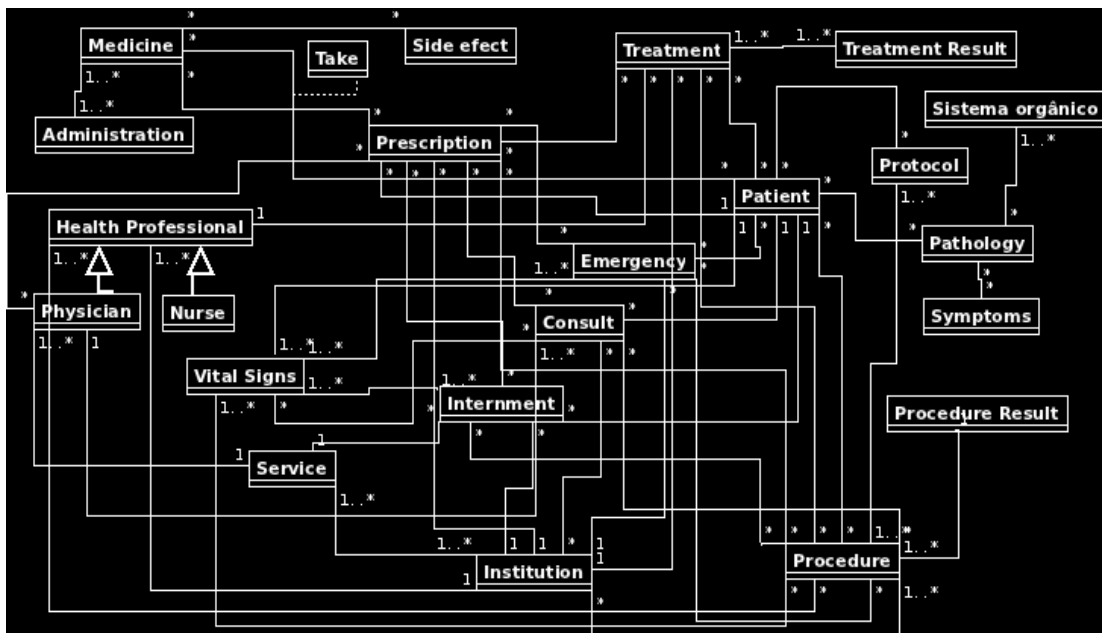

Figure 1. A reduced data model overview

The proposed model is a possible representation of the organization of medical information, it was designed to the implementation of the prototype but it shows the complexity of this type of information systems even if in a small scale like in this work.

Some classes have been left out due to the lack of space, mainly inheritance relations, but that does not affects the global design of the model.

One of the reasons that health information systems become so complex was the increase of diagnostic and therapeutic procedures and the necessity to store and process the data they produce (Haux, 2006b).

4. PROPOSED ARCHITECTURE

Currently an architecture based on services using web services is one of the options in use to promote interoperability among heterogeneous information systems (Serbanati, 2011; Liu 2009; Wright, 2008; Mykkanen, 2007).

The technologies used to promote ubiquity of medical information ranging from the use of agents, for communicate in heterogeneous environments connected by communication networks, like the Internet, for remote monitoring (Su, 2011, Sneha, 2009), web services, for the creation of basic services that serve as base for the creation of more complex services (Han, 2010), ZigBee for the communication with biosensors (Lee, 2009), infrared for communication between devices (Michalowski, 2003), 802.11 networks for communicating with a server using a ADSL connection for documenting of patient care by health professionals (Chau, 2006), cable television systems and 802.11 networks for monitoring vital parameters and create medical information in an ubiquitous form (Lin, 2008).

To ensure interoperability among the different systems we propose an architecture based on services using web services and specifications as WSDL, SOAP and UDDI.

The use of web services will also serve to communicate with mobile devices with the Android platform making use of ubiquitous computing.

The Hospital (H), Primary Care (PC) and Medical Emergency (ME) subsystems (Figure 2) represented by the Institution in the data model (Figure 1), represent the hospitals, health centers and medical emergency respectively. The GLOBAL subsystem is where the patient can access his medical and personal information.

The subsystems of the different institutions replicate the information in their databases with the GLOBAL subsystem database on a daily basis.

In each subsystem a central component, responsible by the application logic and the user interface, serves as a bridge between the database and the layer of available services.

The health professional, namely emergency medical, may quickly access all of the patient's information, present in GLOBAL, through a mobile device, using the access interface for mobile devices (WSM). To update the ME subsystem one must access the services provided by him.

The GLOBAL subsystem will consist of a multilayer application with the creation of an access interface for mobile devices using web services.

If the H, PC and ME subsystems, by whatever reason, can't access each other services, they can access the services available in GLOBAL so they can get the information they need.

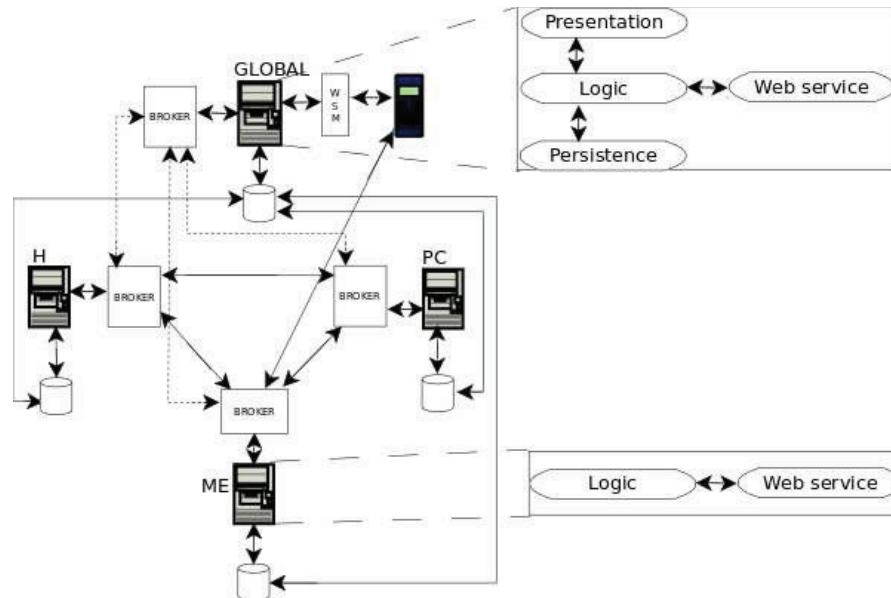

Figure 2. Proposed architecture

The focus of this architecture is to study a way to promote interoperability between heterogeneous systems, show the shortcomings of the systems in use today and the changes that need to be made to these same systems.

The H, CS and EM subsystems already exist, and will not be modified, to promote interoperability between them another piece will be create, represented by the BROKER. The BROKER will encapsulate the interface and its operations that a subsystem will use to obtain information from another subsystem. The BROKER will facilitate the creation of another type of applications in the future, without the need to worry about the internal implementation of the different subsystems.

In the implementation of the prototype the proposed architecture should provide interoperability in three specific cases, consultations in the CS subsystem, surgery/hospitalization in the H subsystem, and an emergency situation outside a health institution in the EM subsystem. For example if a patient was submitted to a surgery, the medical information create during that procedure will be stored in de subsystem H and will be accessible to the other subsystems through the operations provided by the BROKER. The same happens with the information stored in the other subsystems.

The proposed mobile component is something that does not exist today and is a valuable addition to improve the quality of care, prevent mistakes and provide the most relevant information about a patient outside health institutions, as explained in section 3.

In the proposed architecture the patient has easy access to his medical information through the GLOBAL subsystem.

With the proposed architecture the health information systems can interoperate and enables and provides health information to be accessed wherever and whenever needed.

5. DISCUSSION AND FINAL REMARKS

Health information systems are extremely complex and for a better healthcare assistance in the different levels of care they shouldn't be isolated and they must be able to support decision making in emergency situations.

This work presents a proposal to promote interoperability between heterogeneous health information systems using web services; it also provides the possibility of ubiquitous access to the information using mobile devices and web services, with the goal to provide a better medical assistance to the patient in and out of health institutions.

A prototype it's being developed to validate the proposed architecture and to try to obtain more information about the impact this architecture could have in the decision making process in healthcare.

REFERENCES

- ANACOM, 2010. Serviços Móveis, Relatório Técnico, Autoridade Nacional de Comunicações. In http://www.anacom.pt/render.jsp?categoryName=CATEGORY_ROOT, Lisboa, Portugal.
- Chau, S. and Turner, P., 2006. Utilisation of mobile handheld devices for care management at an Australian aged care facility. In *Electronic Commerce Research and Applications*, Vol. 5, pp. 305-312.
- Espanha, R. and Fonseca, R., 2010. Plano Nacional de Saúde 2011-2016 “Tecnologias de Informação e Comunicação”, In <http://www.acs.min-saude.pt> , Lisboa, Portugal.
- Han, D. et al, 2010. THE-MUSS: Mobile u-health service system. In *Computer Methods and Programs in Biomedicine*, Vol. 97, Issue 2, pp. 178-188.
- Haux, R. et al, 2006. Individualization, globalization and health – about sustainable information technologies and the aim of medical informatics. In *International Journal of Medical Informatics*, Vol. 75, pp. 795-808.
- Haux, R. 2006. Health information systems – past, present, future. In *International Journal of Medical Informatics*, Vol. 75, pp. 268-281.
- Jen, W. et al, 2007. Mobile information and communication in the hospital outpatient service. In *International Journal of Medical Informatics*, Vol. 76, pp. 565-574.
- Jha, A. et al, 2008. The use of health information technology in seven nations. In *International Journal of Medical Informatics*, Vol. 77, pp. 848-854.

- Lee, H. et al, 2009. Ubiquitous health care service using Zigbee and mobile phone for elderly patients. *In International Journal of Medical Informatics*, Vol. 78, pp. 193-198.
- Li, Y. et al, 2001. Building a generic architecture for medical information exchange among healthcare providers. *In International Journal of Medical Informatics*, Vol. 61, Issue 2, pp. 241-246.
- Lin, C et al, 2008. A pervasive health monitoring service system based on ubiquitous network technology. *In International Journal of Medical Informatic*, Vol. 77, pp. 461-469.
- Liu, V. et al, 2009. Open and Trusted Information Systems/Health Informatics Access Control (OTHIS/HIAC). *Proceedings of 7th Australasin Information Security Conference*. Wellington, New Zealand, pp. 99-108.
- Liu, V. et al, 2010. A Secure Architecture for Australia's Index Based E-health Environment. *Proceedings of 4th Australian Workshop of Health Informatics and Knowleged Management*. Brisbane, Australia, pp. 7-16.
- Michalowski, W. et al, 2003. Mobile clinical support system for pediatric emergencies. *In Decision Support Systems*, Vol. 3, pp. 161-176.
- Mykkanen, J. et al, 2007. Designing web services in health information systems: From process to application level. *In International Journal of Medical Informatics*, Vol. 76, Issues 2-3, pp. 89-95.
- Orgun, B. and Vu, J., 2006. HL7 ontology and mobile agents for interoperability in heterogenous medical infomation systems. *In Computers in Biology and Medicine*, Vol. 36, Issues 2-3, pp. 817-836.
- Raghupathi, W. and Umar. A., 2008. Exploring a model-driven architecture (MDA) approach to health care information systems development. *In International Journal of Medical Informatics*, Vol. 77, Issue 5, pp. 305-314.
- Rigby, M., 2007. Applying emergent ubiquitous technologies in health: The need to respond to new challenges of opportunity, expectation, and responsibility. *In International Journal of Medical Informatics*, Vol. 76, pp. 349-352.
- Serbanati, L. et al, 2011. Steps towards a digital health ecosystem. *In Journal on Biomedical Informatics*, doi:10.1016/j.jbi.2011.02.011.
- Sneha, A. Varshney, U., 2009. Enabling ubiquitous patient monitoring: Model, decision protocols, opportunities and challanges. *In Decision Support Systems*, Vol 46, pp. 606-619.
- Su, C. and Wu, C., 2011. JADE implemented mobile multi-agent based, distributed information platform for pervasive health care monitoring. *In Applied Soft Computing*, Vol. 11, No 1, pp. 315-325.
- Wright, A. and Sittig, D., 2008. SANDS: A service-oriented architecture for clinical decision support in a National Information Network. *In Journal of Biomedical Informatics*, Vol. 41, Issue 5, pp. 962-981.