

**DETERMINATION OF STRESS INTENSITY FACTORS ALONG CRACKED SURFACES IN
PIPING ELBOWS STRUCTURES**

E.M.M.FONSECA*, F.Q.MELO, R.A.F.VALENTE****

***CENUME – IDMEC**

**Instituto Politécnico de Bragança - Apartado 1134, 5301-051 Bragança, Portugal
efonseca@ipb.pt**

**** Department of Mechanical Engineering, Universidade de Aveiro
Campus Universitário de Santiago, 3810-193 Aveiro, Portugal
fqm@mec.ua.pt robertt@mec.ua.pt**

Abstract. Pipe elbows play an essential role in pipework systems, once such structure elements are part of the plant process fluid conduction practically in all chemical or energy production industries. High safety standards in design are inherent to these projects due to complex mechanical or thermal loading. When these accessories carry defects, project engineers should assess their integrity in duty. This paper present a contribution in fracture mechanics applied to piping systems. Stress intensity factors are determined along cracked surfaces in piping elbows subjected to bending moment using a developed finite curved pipe element. This element is based in high order polynomial for rigid beam displacement and Fourier series modelling the transverse section warping or ovalization. Computational effort is saved with this element in the evaluation of the stresses or strains. Numerical tests are performed for different pipe elbows with thick or thin flanges, containing a circumferential crack. This study is compared with analyses reported by other authors.

1. INTRODUCTION

In fracture mechanics the way in which a crack is built up is not necessarily relevant; yet it is important to assess how an existing discrete crack can affect the continued operating life of the structural part carrying the defect. In a stressed structural component with defects, a crack may remain still or propagate, eventually driving the component to fail catastrophically if the nominal stresses field determines a critical value for the Stress Intensity Factor (SIF) associated with the crack shape. The mechanical operating conditions are very important. The loading conditions may involve complex force system, thermal expansion effects, dynamic actions, material non-homogeneity (anisotropy) properties, where these factors present an important role on the discrete crack evolution (Hellen 2001). Practical solutions in fracture mechanics problems are easy to obtain when the finite element method is applied given its wide versatility and accuracy.

The purpose of this work has a major incidence on the evaluation of the SIF, a fracture parameter of leading importance at any point along a crack eventually existing in pipe elbows. In a Linear Elastic Fracture Mechanics (LEFM) criterion the contribution of the plastic area in the vicinity of a crack tip is neglected. The SIF value depends upon the crack length; the nominal stress near the crack tip and a factor considering the component geometry with deriving expressions involving some difficulty due to the characterization of the singularity at the crack tip. The stress at the tip is plastic and in elastic analysis tends to infinity (Bishop and Sherratt 2000) [2].

The proposed finite element as a tool to reduce the amount of work invested in the assessment of the integrity of pipe elements eventually containing cracks. This type of structural defects may arise as curved pipes present a stress field with a remarkable variation when subjected to bending efforts; there are zones where the stress intensity may develop cracks which may propagate if the external loads are time dependent as a consequence of a fatigue phenomenon.

The problem of the evaluation of the SIF along a crack existing in a pipe (Kumar et al 1985) [3], (Parks et al 1981) [4] is normally a task demanding some amount of computational effort, once for a reliable analysis, a highly refined mesh geometry is necessary in the vicinity of the structural singularity. An economic alternative consists on the analysis of only a part of the shell containing the defect and discretized into a finite element mesh. A more elaborated finite element mesh modelling the cracked

shell consists on the use of 3D finite elements (Newman and Raju 1981) [5], an option that generally involves a large number of unknowns and a less favourable consequence on the computation time; alternatively, that type of singularity may be modelled with the Line-Spring Model (LSM) (Kumar et al 1985) [3], (Oliveira et al 1991) [6]. The concept of LSM introduced by (Rice and Levy 1972) [7] is a powerful tool when included in other element codes to assess the structural integrity of components containing cracks (Oliveira et al 1991) [6].

The present pipe element appears as an attractive tool in the definition of the stress field along the edges of the shell element decoupled from the curved pipe. Once defined the stress field along the edges of the pipe part containing the crack, an approached procedure can be carried out even without a subsequent finite element analysis, using published graphical results (Kumar et al 1985) [3], (Parks et al 1981) [4], (Delale and Erdogan 1981) [8].

2. THE FORMULATION OF THE PIPING ELBOW ELEMENT

The geometric parameters considered for the piping elbow element definition are: the arc length (s), the mean curvature radius (R), the thickness (h), the mean section radius of the pipe (r) and the central angle (α). The total number of degrees of freedom for this element is 19 for each nodal section, being 2 translations, 1 rotation and 8 terms used in Fourier expansions. Figures 1 and 2 resume the geometric parameters and degrees of freedom for in-plane piping elbow element.

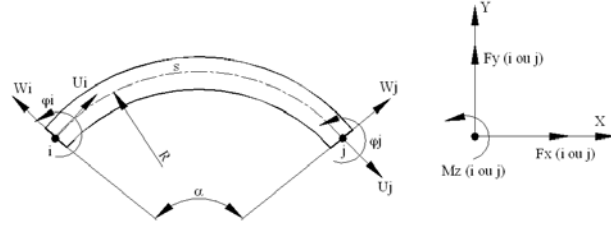
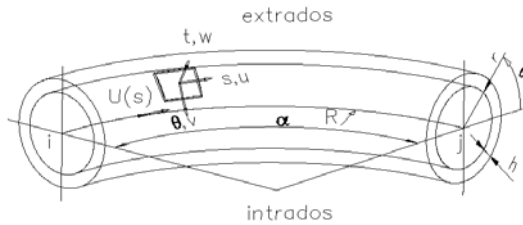

Fig. 1 - Geometric parameters for pipe elbow.

Fig. 2 - Degrees of freedom for in-plane.

The deformation field of a piping elbow element refers to membrane strains and shell curvature variations. The following assumptions, referred in (Fonseca et al 2005-2002) [9-10], (Melo and Castro 1992) [11], were considered in the present analysis: the curvature radius is assumed much larger than the section radius; a semi-membrane deformation model is adopted and neglects the bending stiffness along the longitudinal direction of the toroidal shell but considers the meridional bending resulting from ovalization. The shell is considered thin and inextensible along the meridional direction for only the mechanical loading case.

The shell finite element displacement field (u, v e w), as shown figure 1, resulting from the superposition of rigid beam displacement under mean line arc ($U_{(s)}$, $W_{(s)}$ and $\Phi_{(s)}$) and the complete Fourier expansion for ovalization and warping terms, as show in the following equations:

$$u = U_{(s)} - r \cos \theta \varphi_{(s)} + u_{(s,\theta)} \quad (1)$$

$$v = -W_{(s)} \sin \theta + v_{(s,\theta)} \quad (2)$$

$$w = W_{(s)} \cos \theta + w_{(s,\theta)} \quad (3)$$

The surfaces displacements in radial direction and in meridional direction result from ovalization, in-plane, as referred by (Thomson 1980) [12] and are expressed by the following equations:

$$w_{(s,\theta)} = \left(\sum_{n \geq 2} a_n \cos n\theta \right) N_i + \left(\sum_{n \geq 2} a_n \cos n\theta \right) N_j \quad (4)$$

$$v_{(s,\theta)} = \left(- \sum_{n \geq 2} \frac{a_n}{n} \sin n\theta \right) N_i + \left(- \sum_{n \geq 2} \frac{a_n}{n} \sin n\theta \right) N_j \quad (5)$$

The longitudinal displacement due to warping tubular section effect is calculated by the following equation, referred by (Thomson 1980) [12]:

$$u_{(s,\theta)} = \left(\sum_{n \geq 2} b_n \cos n\theta \right) N_i + \left(\sum_{n \geq 2} b_n \cos n\theta \right) N_j \quad (6)$$

The terms a_n and b_n are constants to be determined as function of developed Fourier series.

A model will be presented for the displacement field calculation in piping elbow elements. In this model, a high order formulation should be used and six parameters are necessary to define the beam displacement field. From this, $U_{(s)}$ can be approached by the following fifth order polynomial (5P):

$$U_{(s)} = a_0 + a_1s + a_2s^2 + a_3s^3 + a_4s^4 + a_5s^5 \quad (7)$$

The transverse displacement and the rotation can be calculated:

$$W_{(s)} = -R \frac{dU}{ds} = -R(a_1 + 2a_2s + 3a_3s^2 + 4a_4s^3 + 5a_5s^4) \quad (8)$$

$$\varphi_{(s)} = \frac{dW}{ds} = -R(2a_2 + 6a_3s + 12a_4s^2 + 20a_5s^3) \quad (9)$$

The unknown coefficients are determined as a function of imposed boundary conditions under the curved referential.

For straight pipe elements a formulation based in third order polynomial (3P) was used with Hermitian shape functions.

The deformation model considers that pipe undergoes a semi-membrane strain field and it is represented by the equation 10.

$$\begin{Bmatrix} \varepsilon_{ss} \\ \gamma_{s\theta} \\ \chi_{\theta\theta} \end{Bmatrix} = \begin{bmatrix} \frac{\partial}{\partial s} & -\frac{\sin \theta}{R} & \frac{\cos \theta}{R} \\ \frac{1}{r} \frac{\partial}{\partial \theta} & \frac{\partial}{\partial s} & 0 \\ 0 & -\frac{1}{r^2} \frac{\partial}{\partial \theta} & \frac{1}{r^2} \frac{\partial^2}{\partial \theta^2} \end{bmatrix} \begin{Bmatrix} u \\ v \\ w \end{Bmatrix} \quad (10)$$

ε_{ss} is the longitudinal membrane strain, $\gamma_{s\theta}$ the shear strain and $\chi_{\theta\theta}$ the meridional curvature form ovalization.

The application of the virtual work principle gives finally the system of algebraic equations to be solved. The element stiffness matrix $[K]$ is calculated from the matrix equation 11. A Gaussian integration was carried out along variable s while an exact one was used along the circumferential direction θ .

$$[K] = [T] \left(\int_{\theta} \int_s [B]^T [D] [B] r ds d\theta \right) [T]^T \quad (11)$$

$[T]$ is the transpose matrix for global system, $[B]$ results from the derivative of the shape functions for the finite piping elbow element and the elasticity matrix $[D]$ appears with a simple algebraic definition, dependent of the elastic modulus E , the piping elbow thickness h and Poisson's ratio ν .

$$[D] = \begin{bmatrix} \frac{Eh}{1-\nu^2} & 0 & 0 \\ 0 & \frac{Eh}{2(1+\nu)} & 0 \\ 0 & 0 & \frac{Eh^3}{12(1-\nu^2)} \end{bmatrix} \quad (12)$$

The stress field is obtained for any position of tubular section using Law's Hooke along the length of the element. A Gaussian integration with two points was used.

$$\{\sigma\} = [D]\{\varepsilon\} = [D][B]\{\delta\} \quad (13)$$

The membrane and bending stress are calculated for outside or inside at pipe wall using the following expressions:

$$\sigma_{ss} = \frac{Eh}{1-\nu^2} \left(\varepsilon_{ss} - \nu \gamma_{s\theta} \pm \frac{\nu}{2} \chi_{\theta\theta} \right) \quad (14)$$

$$\sigma_{s\theta} = \frac{Eh}{1-\nu^2} \left(-\nu \varepsilon_{ss} \pm \frac{1}{2} \chi_{\theta\theta} \right) \quad (15)$$

σ_{ss} is the longitudinal membrane stress and $\sigma_{s\theta}$ is the meridional bending stress due ovalization section.

3. RESULTS OF SIF

3.1 Approximate evaluation of SIF

In this section, finite piping elbows elements results are presented and compared to normalized values of SIF determination. The studies cases include different analysis in tubular structures with different end constraints and containing surface cracks. All cases are loaded with a bending moment.

The normalized SIF results are presented in the following:

$$F = \frac{K_I}{K_\infty} \quad (16)$$

where

$$K_\infty = \underbrace{(\sigma_{ss} + \sigma_{s\theta})}_{\text{without crack}} \sqrt{\pi a/Q} \quad (17)$$

Q is the square of the complete elliptical integral of the second kind and in approximate form is given by expression 18.

$$Q = 1 + 1.464(L_0/a)^{1.63} \quad (18)$$

The SIF in mode I according (Nobile 2001) [14] is calculated by the following expression for circumferential cracked cylindrical pipe under bending.

$$K_I = \frac{M}{\pi r^2 h} \sqrt{\pi r} f\left(\frac{\alpha}{\pi}\right) \quad (19)$$

The function $f(\alpha/\pi)$ depends of the crack section position and is done by the equation 20.

$$f\left(\frac{\alpha}{\pi}\right) = \sqrt{\frac{I_x}{I_x^{**}} \sin \alpha \left(\cos \alpha + \frac{\sin \alpha}{\pi - \alpha} \right)} \quad (20)$$

The moment inertia for circular section, figure 3, is obtained following approximate formulas for case when thickness is small and $\alpha \leq \pi/2$, respectively.

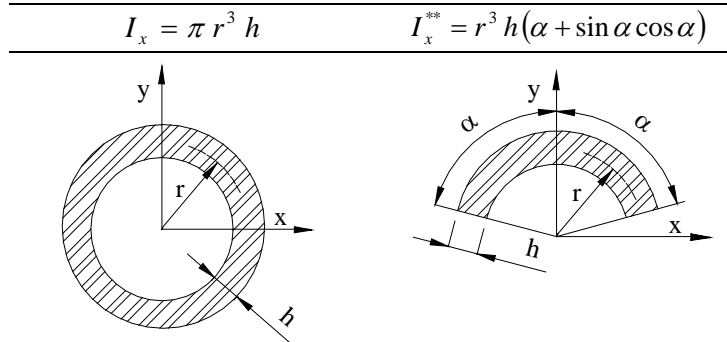

Fig. 3 - Moment inertia for thin ring section.

3.2 A circumferential cracked pipe elbow in extrados under bending moment

The pipe elbow considered is presented in figure 4 with a circumferential part-through crack under a bending moment. The pipe elbow factor considered is $\bar{h} = hR/r^2 = 0.26$ and the relation between wall thickness and semi-crack length $h/a = 0.1$ in all studied cases, such as studied by Melo and Oliveira using LSM (Oliveira et al 1991) [6]. The moment is applied at the end of pipe elbow in a thin flange. The other end pipe elbow has a rigid or thin extremity with a circumferential crack in extrados.

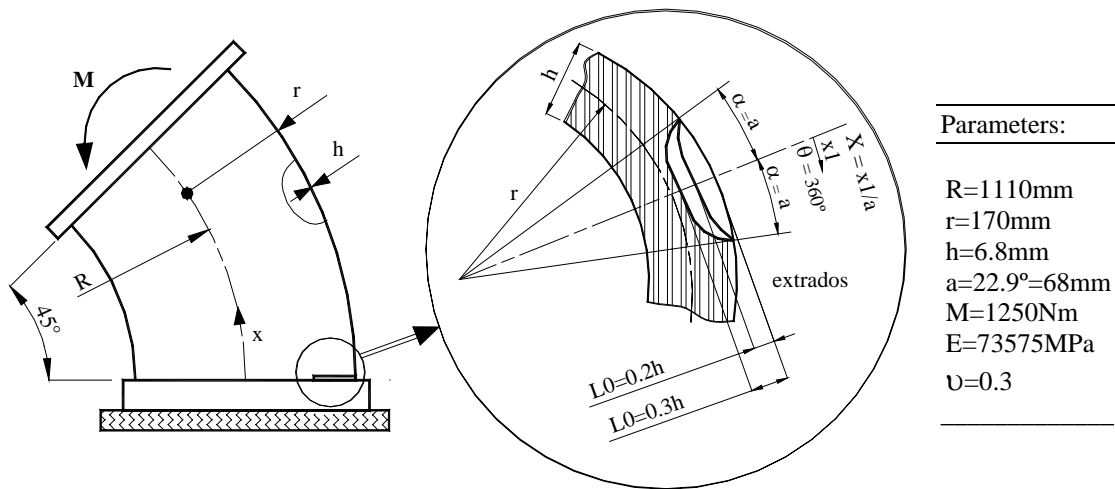

Fig. 4 - A pipe elbow geometry with a circumferential crack in extrados.

For all studied cases, the pipe geometry is the same and only the depth of the part-through crack L_0 is variable according table 1.

Table 1 – Different depth of the part-through crack in piping elbows analysed.

Studied case n°1	Studied case n°2
$\frac{L_0}{h} = 0.2$	$\frac{L_0}{h} = 0.3$
$\frac{L_0}{a} = 0.02$	$\frac{L_0}{a} = 0.03$
$L_0 = 1.36\text{mm}$	$L_0 = 2.04\text{mm}$

Three different one dimensional meshes were used in our program for modelling the pipe elbow geometry, figure 5. In the mesh with 10 elements, all elements along pipe elbow have the same length. In the meshes with 19 or 29 elements different lengths and a more reduced length near of end constraint was considered.

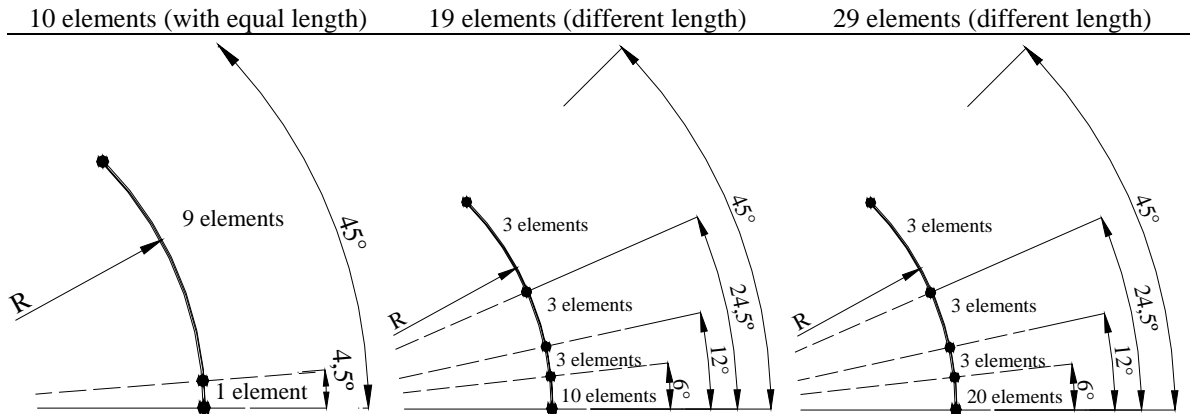

Fig. 5 - Different one dimensional mesh used.

Different solution for longitudinal and bending stresses calculation was obtained near of at the end uncracked zone in extrados with rigid or thin flange, when using a more discretized mesh, such as represented in figure 6 and 7.

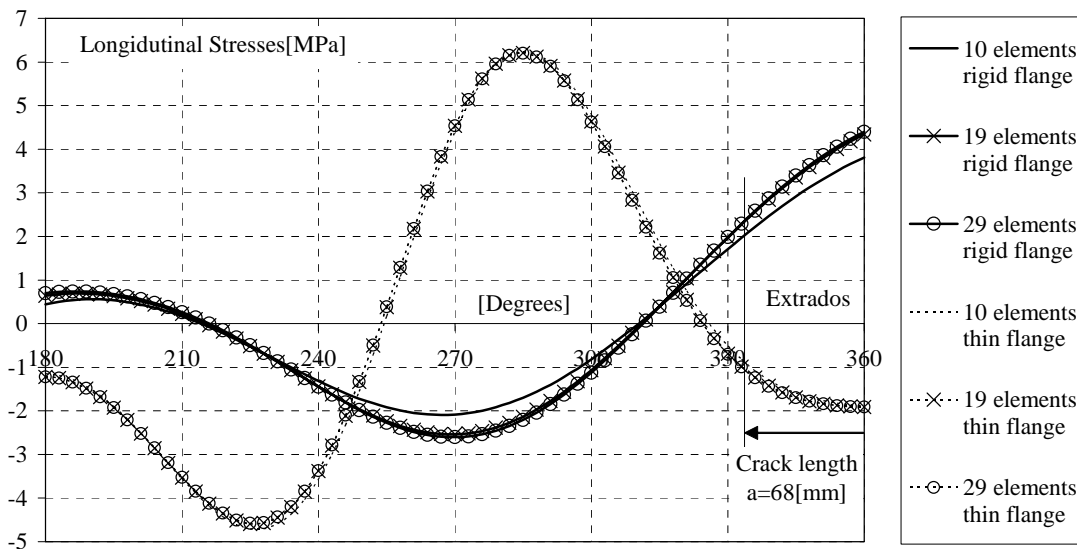

Fig. 6 - Outside longitudinal membrane stresses in extrados with rigid and thin flange with 5P.

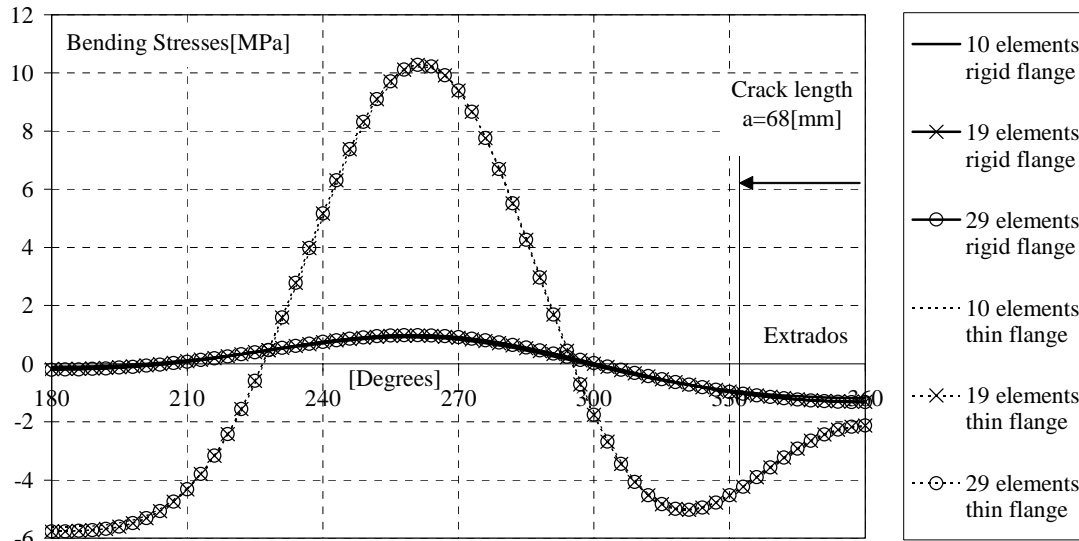

Fig. 7 - Outside meridional bending stresses in extrados with rigid and thin flange with 5P model.

Figure 8 represents the results obtained of normalized values (equation 19) of SIF values in pipe elbows under bending moment for different depth of the part-through crack situations related, using 5P model and compared with LSM from reference [6].

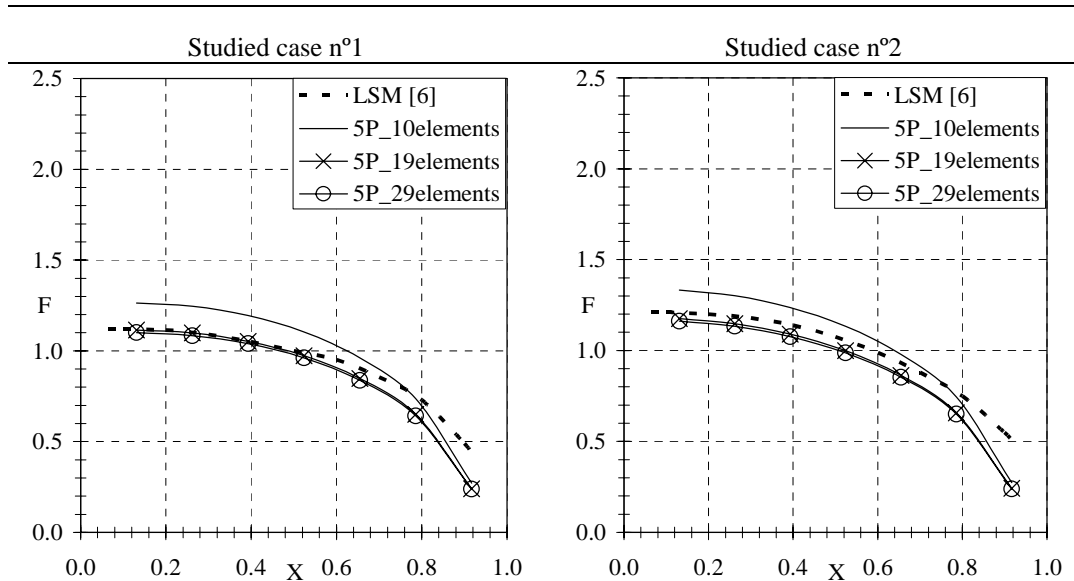

Fig. 8 - Normalized values of SIF obtained from meridional outside crack in extrados with rigid flange.

The mesh with 10 elements presents a more instability behaviour when compared with LSM model in figure 8, due the result obtained with the stress field as show in figure 6.

Figure 9 represents the results obtained of normalized values (equation 19) of SIF in pipe elbows under bending moment for different depth of the part-through crack situations related, using 5P model.

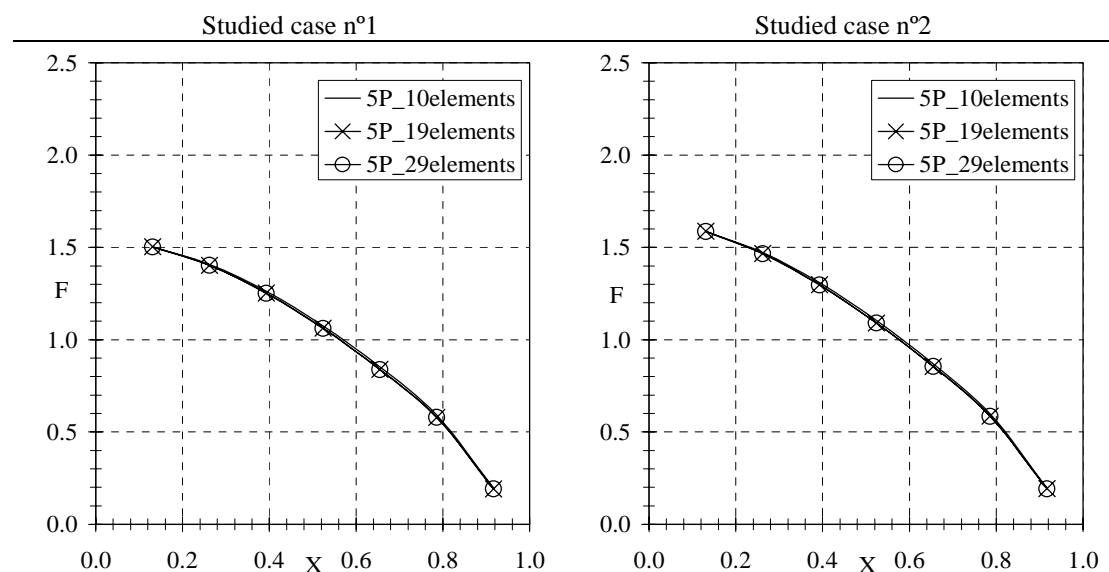

Fig. 9 - Normalized values of SIF obtained from meridional outside crack in extrados with thin flange.

The SIF results increase with the increase of the depth of the part-through crack for all types of end constraints in the pipe elbow. The increase is greater when the end constraint is considered as a thin flange near at the circumferential crack propagation.

4. CONCLUSIONS

In this work some part-through crack configurations in piping elbows were studied. The presented method has shown accurate values for the stress-intensity factor when compared with corresponding data from other authors. The method is therefore a worth considering alternative to more elaborated procedures in the evaluation of the remote stress field along a crack line. The method proposed takes into account the elastic singularity and is based on the conventional shell deformation model theory adapted to tubular structures.

5. ACKNOWLEDGEMENTS

E.M.M. Fonseca gratefully acknowledges funding from the Portuguese Science and Technology Foundation; grant (SFRH/BPD/26172/2005).

6. REFERENCES

- [1] Hellen, T., "How to undertake fracture mechanics analysis with finite elements", The International Association for the Engineering Analysis Community, 2001 NAFEMS Ltd.
- [2] Bishop, Dr. N. W. M., Sherratt, Dr. F., "Finite element based fatigue calculations", The International Association for the Engineering Analysis Community, 2000 NAFEMS Ltd.
- [3] Kumar, V., German, M. D., Schumacher, B.I., "Analysis of elastic surface cracks in cylinders using the line spring model and shell finite element method", International Journal of Pressure Vessel Technology., 107, 403-411, (1985).
- [4] Parks, D. M., Lockett, R. R., Brockenbrough, J. R., "Stress - Intensity factors for surface - Cracked plates and cylindrical shells using line spring finite elements", Advances in Aerospace Structures and Materials, ASME AD-01, 279-285, (1981).

- [5] Newman, J. C., Raju, I. S., ‘‘An empirical stress – intensity factor equation for the surface crack’’, *Engineering Fracture Mechanics*, 15(1-2), 185-192, (1981).
- [6] Oliveira, C. A. M., Melo, F. J. M. Q., Castro, P. M. S. T., ‘‘The elastic analysis of arbitrary thin shells having part-through cracks using the integrated line spring and the semiloof shell elements’’, *Engineering Fracture Mechanics*, 39, 1027-1035, (1991).
- [7] Rice, J., Levy, N., ‘‘The part-through surface crack in an elastic plate’’, *Journal of Applied Mechanics*, 39, 185-194, (1972).
- [8] Delale, F., Erdogan, F., ‘‘Line–spring model for surface cracks in a Reissner plate’’, *International Journal of Engineering Science*, 19, 1331-1340, (1981).
- [9] Fonseca, E. M. M, Melo F. J. M. Q, Oliveira C. A. M., ‘‘The thermal and mechanical behaviour of structural steel piping systems’’, *International Journal of Pressure Vessels and Piping*, 82(2), 145-153, (2005).
- [10] Fonseca E. M. M, Melo F. J. M. Q, Oliveira C. A. M., ‘‘Determination of flexibility factors on curved pipes with end restraints using a semi-analytic formulation’’, *International Journal of Pressure Vessels and Piping*, 79(12), 829-840 (2002).
- [11] Melo F. J. M. Q., Castro P. M. S. T., ‘‘A reduced integration Mindlin beam element for linear elastic stress analysis of curved pipes under generalized in-plane loading’’, *Computers & Structures*, 43(4), 787-794, (1992).
- [12] Thomson, G. ‘‘The Influence of end constraints on pipe bends’’, PhD Thesis, University of Strathclyde, Scotland, UK, (1980).
- [13] Fonseca , E. M. M, de Melo F. J. M. Q., de Oliveira C. A. M., ‘‘Analysis of piping elbows in plane-bending using two different numerical models’’, José O. Valderrama, Carlos J. Rojas, (Eds.), 7^o Interamerican Congress on Computers Applied to the Process Industry, Vila Real, 195-198, (2005).
- [14] Nobile, L., ‘‘Mixed mode crack initiation and direction in circumferential cracked pipes’’, *Transactions SMiRT 16*, Washington DC, (2001).