

A low cost solution for laboratory experiments in induction motor control

Rui Esteves Araújo ⁽¹⁾, **Vicente Leite** ⁽²⁾, **Diamantino Freitas** ⁽³⁾

^{(1), (3)} FACULDADE DE ENGENHARIA DA UNIVERSIDADE DO PORTO

Rua Dr. Roberto Frias s/n, 4200-465 Porto

Porto, Portugal

Telephone n.º: ¹⁾ 351-22-5081808, ³⁾ 351-22-5081837; fax n.º: ^{1,3)} 351-22-5081443

⁽¹⁾ raraujo@fe.up.pt, ⁽³⁾ dfreitas@fe.up.pt

⁽²⁾ INSTITUTO POLITÉCNICO DE BRAGANÇA - ESCOLA SUPERIOR DE
TECNOLOGIA E DE GESTÃO

Campus de Sta. Apolónia - Apartado 134, 5301-857

Bragança, Portugal

Telephone n.º: 351-273-303158, fax n.º: 351-273-313051

avtl@ipb.pt

Keywords

Education tools, laboratory experiments, power electronics, electric drives, induction motors.

Abstract

In this paper we present a controller suitable for educational activities in electric drives. A prototype has been designed specifically to meet the requirement of low cost and it contains all of the active functions required to implement the open loop control of an induction motor. In this way, the prototype allows the easy assimilation of important concepts and enables the understanding of the enclosed subsystems. Some experiments that highlight the quality of the proposed approach are presented.

Introduction

The importance of the field of Power Electronics and Electric Drives is patent on the great number of meetings and conferences recently promoted and by an increasing number of publications on this field. Moreover, application in industry and other sectors, which affect direct or indirectly our lives, for example in surface transport, reflect the impact of this area. In this scenario, the teaching of Power Electronics and Electric Drives keeps a high importance and actuality in many academic courses in Electrical Engineering.

Although sophisticated equipment and techniques are being more and more allocated to Electrical Engineering curricula, namely, personal computers and simulations tools for Power Electronics, experimentation with real prototypes, data shows and the Internet, the methodology has been more or less the same over the last years. In particular, the responsibility of the learning process is attributed to the instructor being the students only quite passive agents. In the case of studies of Power Electronics and Electric Drives this situation can be inverted by supplying "toys" with which they can practice, construct, and see how "things" are made.

Among the courses in the electrical engineering curricula, the one which deals with Power Electronics and Electric Drives seems to be in the most demanding rank for the students. Our usual form of teaching Power Electronics and Electric Drives requires a degree of abstraction which challenges even the most talented student. This is probably one of the reasons for a steadily decreasing number of students in Power Electronics and Electric Drives classes all over the world. Simply following one of the most general principles of live, the majority of students choose the lowest impedance path through

their curricula. To make it all fit, in some cases, it is possible to sacrifice: rigor for vigor and specific details for general principles.

A second point is depending on a "fashion issue". Some domains, such as Telecommunications and Computer science profit of a strong interest in the students and can distort the real necessities of engineers in industrial sector. Another important aspect is connect with the shortfall in the knowing of what Power Electronics and Electric Drives are, what they are for our lives and also for solving future energy problems of the society. That is why it is crucial to persuade students that Power Electronics and Electric Drives are fields which are worthy of a great interest [1,2,3].

This work is intended to be a contribution to stimulate the student's interest in Power Electronics and Electric Drives as well as to provide skills in electronic design. The ability to correctly interpret and verify results is important not only for electronic design, but also in other work areas where engineers are increasingly relying on industrial systems developed by others. The main goal of the laboratory is to give the possibility to the students to put in practice the theory without spending too much time with details concerning to sophisticated hardware implementations without need of high level and expensive development systems like in [4].

In this work we present a low cost solution to develop an induction motor control prototype to be used in the laboratory, which is easy and safe to handle, manipulate and test. The purpose of this prototype is not centred on achieving a great dynamic performance of the induction motor control, but on highlighting the main concepts of this issue and leading the students to play with the system and practice in laboratory measurements. This prototype has the advantage that the explanations are made with a real and concrete system. On the other hand, an analogue electronic hardware realization uses the know-how of linear and switching electronics already acquired by the students in previous courses.

Principle of operation of the hardware prototype

The complete diagram of the prototype is shown in figure 1. As stated above it has been conceived with the main purpose of full integration in laboratory experiments for the teaching of electric drives concepts and methods. The hardware prototype has been developed to allow the contact of the student with a real solution of three-phase induction motor control. We note that open loop voltage/frequency control is used in numerous industrial applications where the requirements related to the dynamic properties of drive control are of secondary importance. The three major modules of the prototype are: the controller board, the opto-isolation board and the power stage.

Controller board

The open loop voltage/frequency control for a voltage inverter fed induction motor is used because of its simplicity. The principle of operation is also illustrated in figure 1. The speed set-point ω_{ref} determines the inverter frequency directly, after passing through a ramping circuit. The frequency signal simultaneously defines the stator voltage reference to pulse width modulated (PWM) block, U_f , so that the condition of voltage/frequency law is satisfied. In this diagram the main subsystems to be implemented are: ramping circuit, V/F law, PWM modulator.

There are several methods of controlling the voltage output of PWM inverters. One of the most classic methods is sub-harmonic pulse width modulated. In this method the sinusoidal three phase reference voltage waveforms are compared with an isosceles triangular carrier wave. The points of intersection between the curves define the pulse widths. With this method the maximum meaningful value of the modulation index is 1. Although it is possible to increase the modulation index beyond unity the resulting waveforms become more and more close to square waves.

A primary requirement for such a PWM modulator is a variable frequency, variable amplitude three-phase sine wave reference voltage generator with good frequency and amplitude stability. The frequency and amplitude can be independently varied by means of two independent DC control voltages. This reference generator is used to implement the three-phase sub-harmonic PWM modulator. The method involves the use of a quadrature sine-wave oscillator with variable frequency.

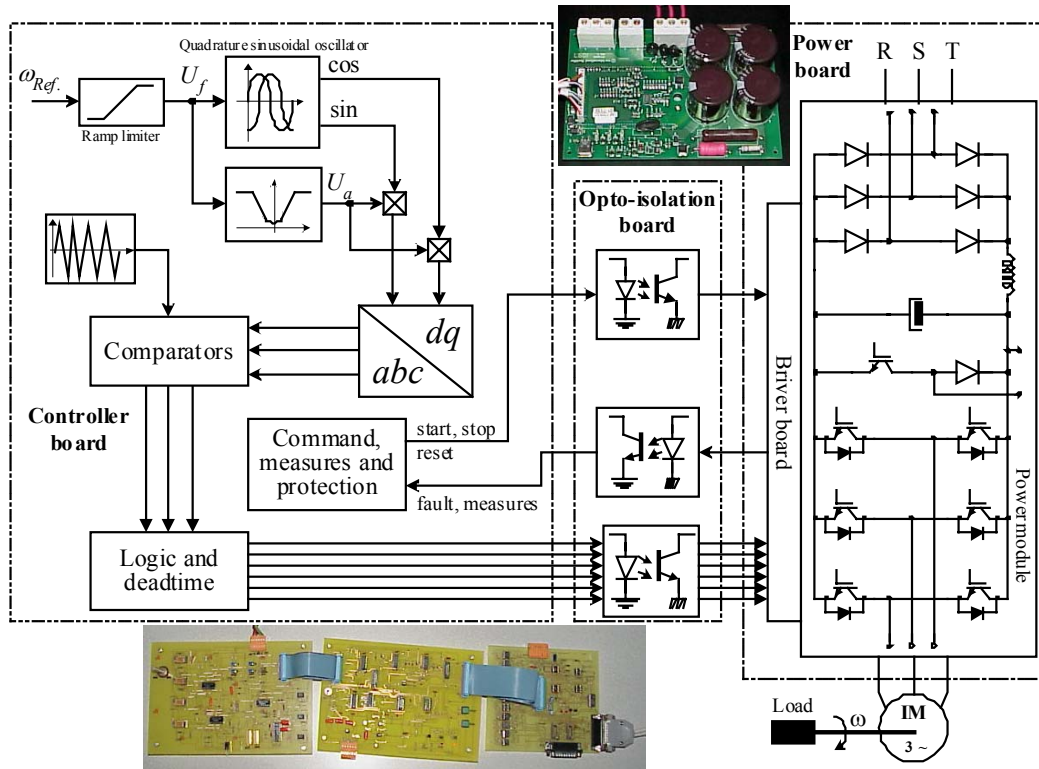

Figure 1: Block diagram of the present prototype.

The frequency varies linearly with the input DC control voltage, U_f . From the output of the quadrature oscillator, two sine waves with a phase difference of 90° are obtained (see figure 2). These two quadrature signals are taken through multipliers where a common DC voltage, U_a , controls the amplitude of the two-phase voltages.

Finally, the two-phase sine wave voltages are then converted to three-phase by proper vectorial transformation (two-phase to three-phase conversion). These waveforms are compared with a triangular carrier wave provide by a signal generator, implemented with integrated circuit MAX038.

Description of the different blocks of the electronically realized instrument

Variable frequency two-phase sinusoidal oscillator

One of the main challenges in this work is the generation of an accurate 90° phase difference between the two-phase signals required by the proposed scheme. Traditional quadrature generators implement a second-order differential equation, which ideally equals $\ddot{x}(t) + x(t) = 0$, $x(t)$ being one of the quadrature oscillator signals. The dot represents differentiation with respect to the time t . The quadrature relation becomes visible only when we split this equation into two equivalent first-order differential equations, to obtain the following state-space equation:

$$\begin{cases} \dot{x}_1(t) = x_2(t) \\ \dot{x}_2(t) = -x_1(t) \end{cases} \quad (1)$$

$x_1(t)$ and $x_2(t)$ are the two quadrature oscillator signals. In order to compensate the effects of non-idealities such as noise and drift in the oscillator circuitry, which will cause oscillator amplitudes to be unstable, all practical second-order oscillators somehow implement the nonlinear second order differential equation $\ddot{x}(t) + f[x(t)]x(t) = 0$, where $f(x)$ is an arbitrary even-symmetry function of x . When $f(x) > 0$, the oscillator is damped and the amplitude decreases. When $f(x) < 0$, the oscillator is undamped and the amplitude increases. The practical circuit consists of two integrators in a negative

The electronic circuit for the implementation of the voltage/frequency law and speed inversion is shown in figure 3. The control input that consists of a DC voltage in the range $\pm 10V$, determines the speed reference, ω_{ref} , and imposes the inverter output frequency, after passing through a ramping limiter based on a low-pass filter and a precision full wave rectifier circuit based on the operational amplifiers B and C shown in the circuit of figure 3. This frequency control signal also defines, simultaneously, the stator voltage reference in the PWM modulator block, in order to satisfy the voltage/frequency law. This is implemented by the operational amplifiers D and E and an analogue switch. The lowest frequency and stator voltage are imposed, respectively, by operational amplifiers F and G. These DC voltages for frequency and amplitude control of the quadrature sinusoids versus DC input voltage control, are plotted in figure 5.

The two amplitude control outputs of the electronic circuit in figure 3 are then multiplied by the respective two-quadrature sinusoids provided by the voltage controlled quadrature sinusoidal oscillator in figure 2. After this multiplication we have the dq components of the stator voltage space phasor reference. These two orthogonal voltages are then converted into a three-phase 120 degree equivalent system of voltages being the reference for the PWM modulation block (see figure 4). Whenever the DC control voltage, that serves as speed reference, changes its signal from positive to negative or vice-versa, one of the two orthogonal sinusoids, which are at their minimum amplitude, is inverted by means of a circuit based on a comparator and an analog switch represented by the lower dotted line in figure 3, enabling the inversion of the mechanical speed. The signals in both figures 5 and 6 were obtained by means of a data acquisition system. Figure 6 shows the three-phase reference system in an inversion of rotation.

The design of the circuits which form the three-phase signals (u_a , u_b , and u_c) for each frequency from the d and q signals was based on the following equations:

$$\begin{cases} u_a = u_d \\ u_b = -\frac{1}{2}u_d + \frac{\sqrt{3}}{2}u_q \\ u_c = -\frac{1}{2}u_d - \frac{\sqrt{3}}{2}u_q \end{cases} \quad (2)$$

Thus, the voltage u_a , u_b , and u_c can be generated using simple adders with fixed dividing resistors. Three phase waveforms of 45 Hz are shown in figure 7. The pulse width modulation is based on the production of an output voltage consisting of constant amplitude, variable pulse width, which is

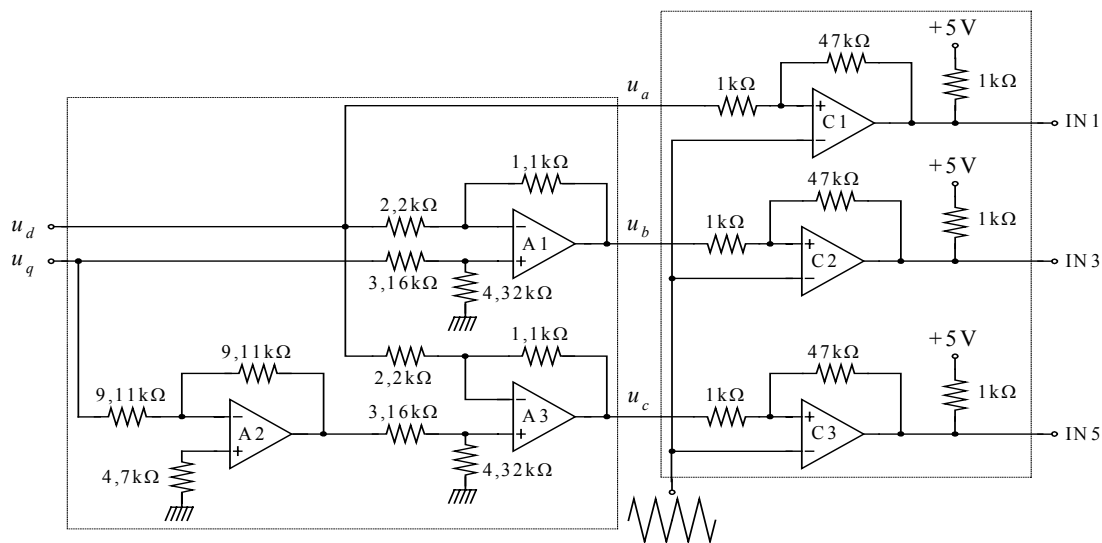

Figure 4: Two-phase to three phase conversion and PWM modulator circuit.

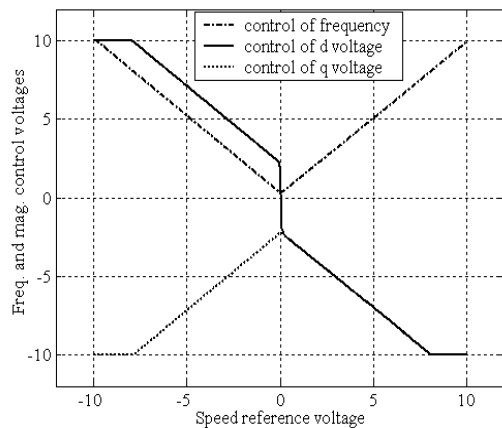

Figure 5: DC voltages for frequency and amplitude control of the quadrature sinusoids versus DC input voltage control.

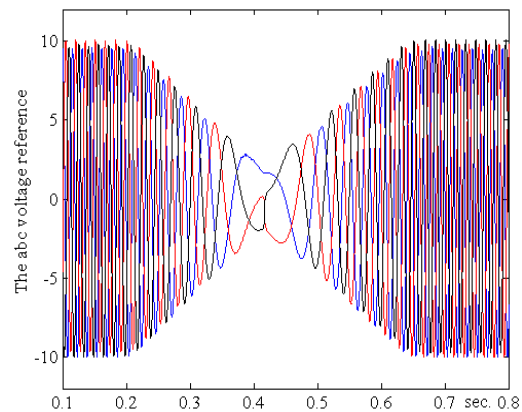

Figure 6: The three-phase reference system of voltages during an inversion of rotation.

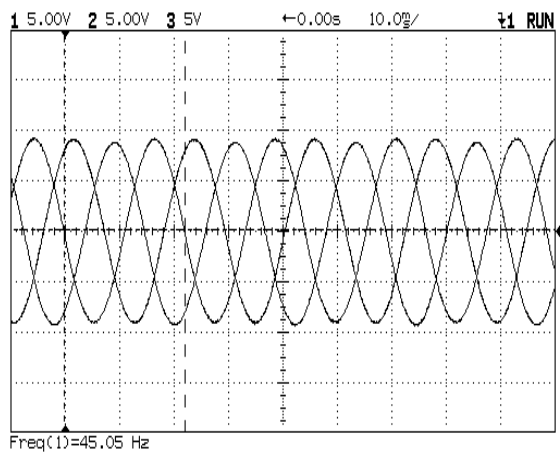

Figure 7: Three phase waveforms at 45 Hz.

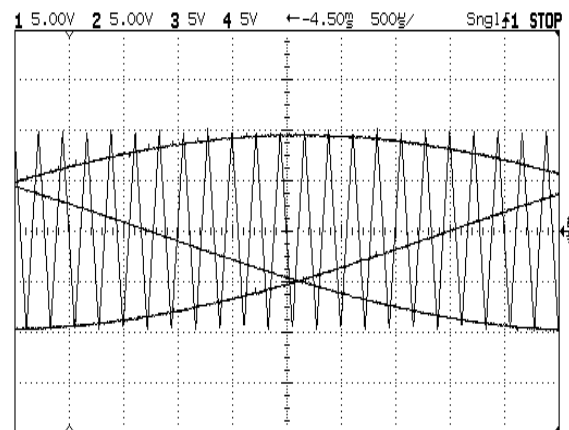

Figure 8: Three reference sinusoids and carrier signal.

supplied to an opto-isolation board. The method used to vary the pulse width is based on the three comparators (C_1 , C_2 , C_3) and the signal generator MAX038 that generate a high frequency triangular wave. The cross-over points of the signal and the triangular waveform are used to generate the pulses required to command the power board (see figure 8). Between the opto-isolation and controller boards there is an interface board that implements the dead-time, processes faults detection and measurements as well as the logic signals of command like *stop*, *start* and *reset*.

Opto-isolation board

From the system point of view, the opto-isolation board fits into an architecture that is optimised for noise robustness. All drive and feedback signals that flow between the control board and power stage are opto-coupled. The board isolates the controller from dangerous voltages that are present in the power board. The gate drive signals are passed from controller to power stage via high-speed, high dv/dt, digital opto-couplers. Analog feedback signals are passed back through high-linearity analog opto-couplers. This board transfers 11 digital signals and 2 analog signals. Digital signals use similar circuit blocks, which are repeated for each signal. Similarly, for the analog circuitry. The digital opto-isolation circuit is relatively simple. It is based on the HCPL2611 high dv/dt opto-coupler. This type of opto-couplers has been selected for their noise immunity and high dv/dt withstanding capability. They provide a robust separation between power stage noise and the controller board.

Power board

The power stage board is based on a low cost commercial and integrated Design Kit, namely, IRMDAC3 from International Rectifier company. It is a kit of parts that work together as an evaluation platform for the three phase motor control IC IR2233 and the power module IRPT2062A. A driver PCB board receives power from the three phase lines and control signals provided by the user's controller board. It supports surge suppression, reduces inrush current and provides DC bus current and voltage measurements as well as fault information. In conjunction with the power module the result is an open, flexible and compact power conversion system with all signals available for monitoring as needed.

Experimental results

The prototype has been experimented with success in the frequency range between 1 Hz and 65 Hz. Figure 9 presents a two-phase frequency sweep output voltage test. Similar results with linear response of amplitude and frequency to amplitude and frequency control voltages has also been obtained for other tests. In figure 10 the waveforms obtained under speed reversal are shown, which illustrate inversion circuit operation. In figure 11 we show the transient response in another speed reversal experiment. In channel 1 we can see the inversion of voltage when the speed is need zero (channel 2). Finally, a line-to-line voltage at the inverter output is shown in figure 12 where the frequency of the fundamental component is about 15Hz.

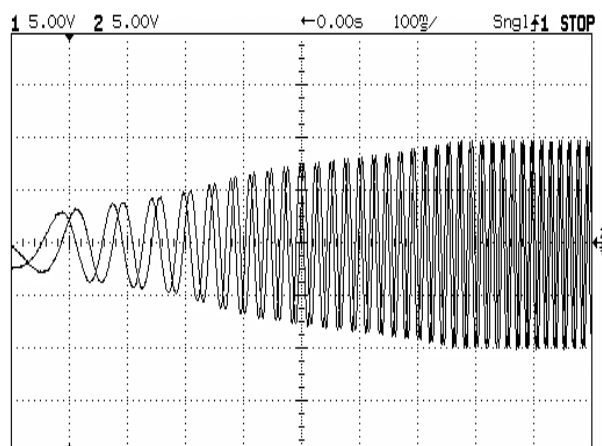

Figure 9: A frequency sweep of two-phase voltage.

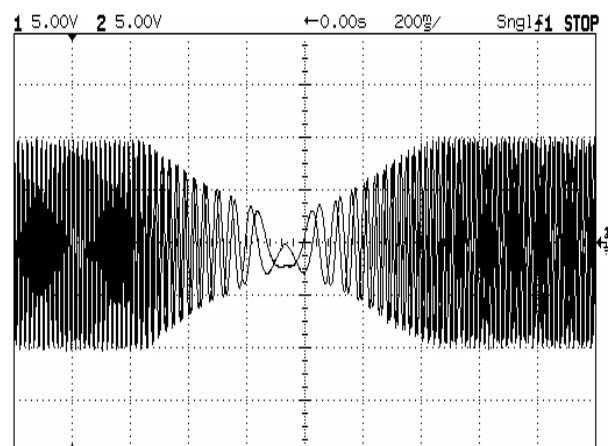

Figure 10: The two-phase signals in an inversion.

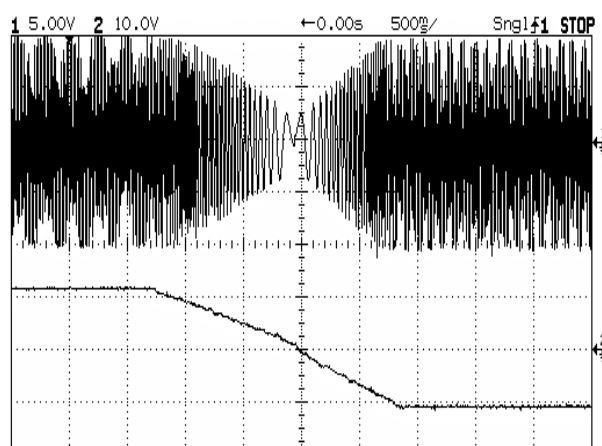

Figure 11: Oscillogram illustrating speed reversal.

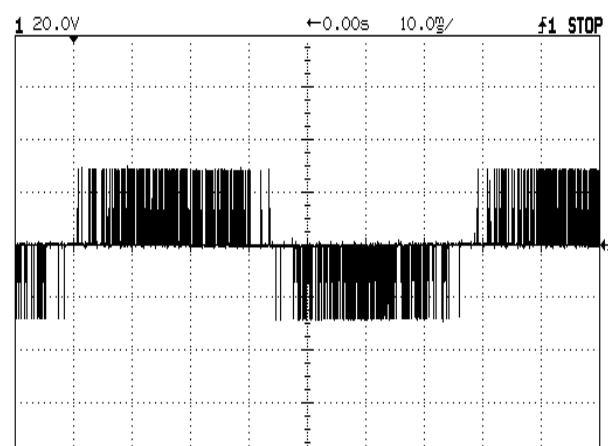

Figure 12: The inverter output line-to-line voltage.

Conclusions

The present paper has described a new method of design of an analog controller for an induction motor. The developed hardware prototype allows the easy assimilation of different concepts and enables the understanding of the enclosed subsystems in order to stimulate the student interest in power electronics as well as to provide him (her) with practical electronic design. The hardware realization of the method has been carried out successfully and yielded an instrument whose basic characteristics have been presented in the paper. Another additional advantage of the realized prototype is its low price when compared to that of an instrument constructed by digital methods. The design and operation of the prototype has been described. The unit forms a versatile laboratory facility for the teaching of electric drives. Regarding the disinterest of students in front of Power Electronics and Electric Drives, we have explained what is our actual policy in laboratory to attract them into this domain by using the control system to play with work aiming a practical understanding and exercising of the actual concepts.

References

- [1] C. Fernández, O. García, J. A. Cobos, J. Uceda, Hardware and Software Environment for Self-learning in Power Electronics, *10th International Power Electronics and Motion Control Conference, EPE-PEMC 2002*, Croatia, September, 2002
- [2] T. Undeland, N. Mohan, Meeting the Challenge: Revitalizing courses in Power Electronics and Electric Drives, *Nordic Workshop on Power and Industrial Electronics, NORPIE 2002*, Sweden, August, 2002
- [3] P. Barrade, A. Rufer, Teaching Power Electronics: stirring up the interest and methodology of teaching with contribution of new technologies, *EPE-E=TeM², Tomorrow's Education in Electrical Technologies revisited Methods & Tools for renewed Motivation*, Belgium, March, 2001
- [4] R. Teodorescu, M. Bech, A. Jorgensen, K. Larsen, F. Blaabjerk, J. Pedersen, *Advanced Prototyping Tools for Project- and Problem-Based Learning*, in Proc. EPE-PEMC02, Dubrovnic & Cavtat, Croatia, July 2002