

- 532 Reporting the degree of deacetylation of chitosan produced by enzyme treatment  
*Del Aguila, Eduardo M.; Gomes, Laidson P.; Andrade, Cristina T.; Silva, Joab T.; Paschoalin, Vania M. F.*
- 534 Selective Synthesis of New Monomers Under Microwave Irradiation for Applications of PDLC Films in Memory Effect Devices  
*Mouquinho, Ana Isabel*
- 536 Smart chitosan-collagen based scaffolds for pulsatile drug release  
*Barroso, Telma Godinho; Viveiros, Raquel; Casimiro, Teresa; Aguiar-Ricardo, Ana*
- 538 Study of the film-forming ability of native agar from an alternative source of *Gracilaria vermiculophylla*  
*Sousa, Ana M.M.; Brandão, Ana T.S.C.; Baldaia, Joana F.F.V.; Rocha, Cristina Maria R.; Gonçalves, Maria do Pilar*
- 540 Physical characteristics of dulce de leche with coffee and partial replacement of whey  
*SANTOS, GABRIELLA; PIMENTA, CARLOS JOSÉ; FERREIRA, LARISSA DE OLIVEIRA; PIMENTA, MARIA EMÍLIA DE SOUSA GOMES; OLIVEIRA, ROSEANE MARIA EVANGELISTA; LEAL, RENATO SILVA; AZEVEDO, VIVIANE MACHADO*
- 543 Desilication of FER zeolite by microwave assisted heating  
*Machado, Vanessa; Belmokhtar, Nourddine; Barata, Patrícia; Costa, Alexandra; Prata, José; Rocha, João; Achak, Ouafae; Chafik, Tarik; Martins, Angela; Carvalho, Ana Paula*

## Wednesday, 7th September

545

### Plenary 6

545

- 545 ENCOURAGING ENTREPRENEURSHIP IN AN ACADEMIC ENVIRONMENT  
*Christopher Lowe*

### Session 10: Materials development for process and product innovation

546

- 546 A high-pressure/supercritical method to dry silica-based materials prepared by biomimetic aqueous sol-gel methods  
*Braga, Mara E.M.; Chim, Rita B.; Alves, Maria C.; Ziegler, C.R.; Watkins, Jim J.; de Sousa, Herminio C.*
- 548 Zeolite Beta Membranes for the Octane Upgrading of C5/C6 Light Naphta  
*Correia Silva, José António; Bárcia, Patrick; Rodrigues, Alirio*
- 550 Control of theophylline crystalline forms using supercritical fluids  
*Padrela, Luis Miguel; Rodrigues, Miguel Ângelo; Velaga, Sitaram; Fernandes, Anabela; Matos, Henrique Âmbal; Azevedo, Edmundo Gomes*
- 552 Chitosan microparticles loaded with essential oils having in view leather applications  
*Fernandes, Isabel Patrícia; Amaral, Joana Andrea; Pinto, Vera; Ferreira, Maria José; Barreiro, Maria Filomena*
- 554 Synthesis and Characterization of pH-Sensitive Acrylamide/Acrylic Acid Hydrogels  
*Pinto, Virgínia; Gonçalves, Miguel; Dias, Rolando Carlos; Costa, Mário Rui*
- 556 Characterization of Biomedical Grade Poly(vinyl chloride) Films Plasticized With Ionic Liquids  
*Marceneiro, Sofia; Dias, Ana M.A. Dias; Braga, Mara E.M.; Coelho, Jorge F.J.; Ferreira, Abel G.M.; Simões, Pedro N.; Matias, Ana; Duarte, Catarina M.M.; Tomé, Lillian C.; Marrucho, Isabel M.; Esperança, José M.S.S.; Rebelo, Luís P.N.; de Sousa, Hermínio C.)*

### Session 11: Process development: intensification and sustainability

558

- 558 Gas-Phase Simulated Moving Bed separation of propane/propylene: is it worth it?  
*Sa Gomes, Pedro; Barton, Paul I.; Rodrigues, Alirio E.*
- 560 Camphene hydration over sulfonated PVA membranes  
*Vital, Joaquim; Machado, Ângela; Castanheiro, José Eduardo; Ramos, Ana Maria; Pinto, Joana Vaz*
- 562 Chiral Separation of Non-Steroidal Anti-Inflammatory Drugs by Preparative and Simulated Moving Bed Chromatography  
*Ribeiro, António E.; Sá Gomes, Pedro; Pais, Luís S.; Rodrigues, Alirio E.*

## Zeolite Beta Membranes for the Octane Upgrading of C5/C6 Light Naphta

Patrick S. Bárcia<sup>1</sup>, Alexandre Ferreira<sup>3</sup>, Jorge Gascon<sup>3\*</sup>, Sonia Aguado<sup>3</sup>, Alírio E. Rodrigues<sup>2</sup>, Freek Kapteijn<sup>3</sup>, José A.C. Silva<sup>1\*</sup>

<sup>1</sup>Escola Superior de Tecnologia e Gestão, Instituto Politécnico de Bragança, Apartado 1134, 5301-857 Bragança, Portugal,

<sup>2</sup>Laboratory of Separation and Reaction Engineering, Departamento de Engenharia Química, Faculdade de Engenharia, Universidade do Porto, Rua do Dr. Roberto Frias, S/N 4200-465 Porto, Portugal,

<sup>3</sup>Catalysis Engineering, DelftChemTech, Delft University of Technology, Julianalaan 136, 2628 BL Delft, The Netherlands.

\* jsilva@ipb.pt

One of the major processes in the oil refinery is the isomerization of light parafins which increase the octane rating of low-grade linear alkanes. The conversion from linear to branched is often performed on a platinum loaded mordenite catalyst (Pt-H/MOR). Separation of the non-converted linear molecules is carried out using adsorbing beds of zeolite 5A. Nevertheless, one third of the resulting isomerate consists in low octane number (RON) linear and monobranched alkanes. The oil refining market requires the development of alternative solutions which can improve the RON quality of the gasoline fulfilling at the same time the environmental standards imposed.

Recently, adsorption studies performed at *LSRE-IPB* indicate that zeolite beta can selectively adsorb the low octane C6 isomers from a vapour mixture at low partial pressure by fixed bed technique <sup>[1]</sup>. Such behaviour could be explained by both preferential adsorption and shape selectivity, being the last originated by the presence of two different types of interconnected channels.

At the same time, interest in zeolite membranes has been growing rapidly due to their capability to separate compounds in continuous operation. Since 2008, LSRE has been working in collaboration with the Catalysis Engineering group at *DelftChemTech* (Delft University of Technology, The Netherland) with the goal of exploring the use of zeolite membranes for the separation of hexane isomers. For this purpose, different synthesis methods for manufacturing zeolite beta membranes have been explored and their performance in the vapour phase separation of hexane isomer mixtures studied. This work represents, to the best of our knowledge, the first one dealing with the separation of four C6 isomers (n-hexane (nHEX), 3-methylpentane (3MP), 2,3-dimethylbutane (23DMB) and 2,2-dimethylbutane (22DMB)) using zeolitic membranes.

The zeolite Beta membranes were prepared by secondary growth method in asymmetric tubular  $\alpha$ -Al<sub>2</sub>O<sub>3</sub> supports (*Inocermic GmbH, Germany*), combining three different types of seeding techniques and crystallization conditions. Figure 1 show SEM micrographs of a typical non-calcined beta membrane synthesized in this work (cross section view).

The vapour permeation experiments performed in the apparatus shown in Figure 2 with mixtures of nHEX, 3MP, 23DMB and 22DMB show that permeate flux increase as the degree of branching decreases following the order: nHEX>>3MP>23DMB>22DMB. Approximately one third of the feed stream cross the membranes. Figure 3 shows that in the retentate stream the fractions of monobranched and normal hexane isomers (low RON compounds) decrease while the concentration of dibranched isomers (high RON compounds) is increased in relation to the equimolar feed composition. Consequently, the RON can be boosted in retentate up to 3.8 points. These results demonstrate the potential of the zeolite beta membranes for application in the production of additive-free premium gasoline.

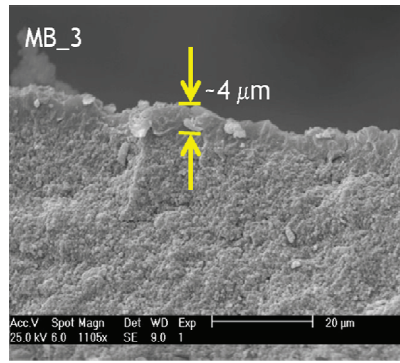

Figure 1. SEM micrographs of a typical non-calcined beta membrane (cross section view).

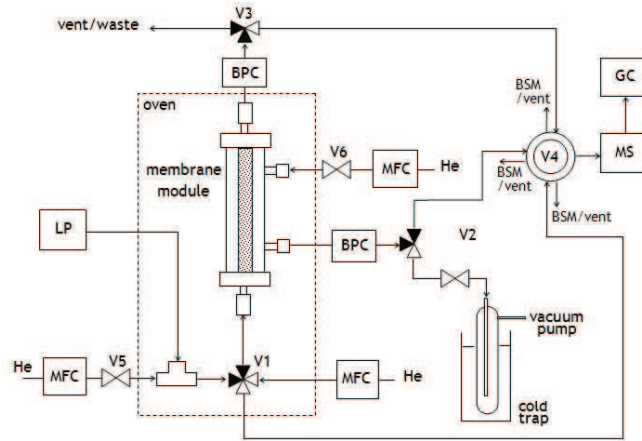

Figure 2. Schematic representation of the experimental apparatus used for vapour permeation tests.

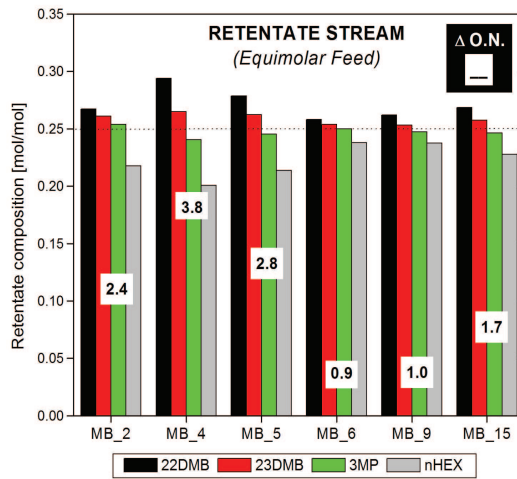

Figure 3. Composition of the retentate for a equimolar feed mixture of nHEX, 3MP, 23DMB and 22DMB at  $T=100\text{ }^{\circ}\text{C}$  and  $p_{\text{mix}}=1\text{ kPa}$  in typical zeolite Beta membrane.

References:

[1] Patrick S. Bárcia, *Separation of light naphtha for the octane upgrading of gasoline: adsorption and membrane technologies and new adsorbents*, Ph.D. Thesis, University of Porto, Portugal, 2010.