



**11TH INTERNATIONAL CONFERENCE OF
EDUCATION,
RESEARCH AND
INNOVATION**

A horizontal band featuring a photograph of a modern building's facade with a complex, geometric, yellow and white pattern. The sky is blue with white clouds. The text 'CONFERENCE PROCEEDINGS' is overlaid in large, bold, white, sans-serif font with a black outline.

**CONFERENCE
PROCEEDINGS**

**SEVILLE (SPAIN)
12-14 NOVEMBER 2018**



**11TH INTERNATIONAL CONFERENCE OF
EDUCATION,
RESEARCH AND
INNOVATION**

**CONFERENCE
PROCEEDINGS**

**SEVILLE (SPAIN)
12-14 NOVEMBER 2018**

Published by
IATED Academy
iated.org

ICERI2018 Proceedings
11th International Conference of Education, Research and Innovation
November 12th-14th, 2018 — Seville, Spain

Edited by
L. Gómez Chova, A. López Martínez, I. Candel Torres
IATED Academy

ISBN: 978-84-09-05948-5
ISSN: 2340-1095
Depósito Legal: V-2884-2018

Book cover designed by
J.L. Bernat

All rights reserved. Copyright © 2018, IATED

The papers published in these proceedings reflect the views only of the authors. The publisher cannot be held responsible for the validity or use of the information therein contained.

ICERI2018 COMMITTEE AND ADVISORY BOARD

<i>Adriana Agnes Repellin-Moreno</i>	MEXICO	<i>Jose F. Cabeza</i>	SPAIN
<i>Agustín López</i>	SPAIN	<i>Jose Luis Bernat</i>	SPAIN
<i>Alan Fenn-Lavington</i>	AUSTRALIA	<i>Juanan Herrero</i>	SPAIN
<i>Amparo Girós</i>	SPAIN	<i>Juliana Mahpol</i>	MALAYSIA
<i>Ana Henriques</i>	PORTUGAL	<i>Ken Brown</i>	IRELAND
<i>Ana Paula Lopes</i>	PORTUGAL	<i>Kenesha Wilson</i>	UNITED ARAB EMIRATES
<i>Ana Tomás</i>	SPAIN	<i>Laurie Henry</i>	UNITED STATES
<i>Anna Romagnuolo</i>	ITALY	<i>Lisa Zawilinski</i>	UNITED STATES
<i>Antonio García</i>	SPAIN	<i>Lorena López</i>	SPAIN
<i>Berit Grønn</i>	NORWAY	<i>Lori Severino</i>	UNITED STATES
<i>Breno Deffanti</i>	BRAZIL	<i>Luca Botturi</i>	SWITZERLAND
<i>Brian Garibaldi</i>	UNITED STATES	<i>Lucilia Falcao</i>	BRAZIL
<i>Chelo González</i>	SPAIN	<i>Luis Gómez Chova</i>	SPAIN
<i>Cherry Poussa</i>	UNITED KINGDOM	<i>Luis Roseiro</i>	PORTUGAL
<i>Christian Grévisse</i>	LUXEMBOURG	<i>Lynn Vona</i>	UNITED STATES
<i>Christine Stanley</i>	UNITED STATES	<i>M^a Jesús Suesta</i>	SPAIN
<i>Christopher Evans</i>	UNITED KINGDOM	<i>Maria Porcel</i>	SPAIN
<i>Christopher Mattatall</i>	CANADA	<i>Marta Alves</i>	PORTUGAL
<i>Craig Loewen</i>	CANADA	<i>Mary Jo Self</i>	UNITED STATES
<i>Cristina Nicolau</i>	ROMANIA	<i>Maya August Finkenberg</i>	UNITED STATES
<i>Cynthia Rosas Magallanes</i>	MEXICO	<i>Michal Gregus</i>	SLOVAKIA
<i>Dale Carnegie</i>	NEW ZEALAND	<i>Michalis Xenos</i>	GREECE
<i>Daniela Buna</i>	UNITED STATES	<i>Miguel Peiró</i>	SPAIN
<i>David Jennings</i>	IRELAND	<i>Miranda Lin</i>	UNITED STATES
<i>David Martí</i>	SPAIN	<i>Nicola Galloway</i>	UNITED KINGDOM
<i>Diane Boothe</i>	UNITED STATES	<i>Norma Barrachina</i>	SPAIN
<i>Dragana Brzakovic</i>	UNITED STATES	<i>Oronzo Parlangei</i>	ITALY
<i>Eduardo Figueira</i>	PORTUGAL	<i>Paul Lane</i>	UNITED STATES
<i>Eladio Duque</i>	SPAIN	<i>Peter Haber</i>	AUSTRIA
<i>Elmaziye Özgür</i>	CYPRUS	<i>Peter Mazohl</i>	AUSTRIA
<i>Fernando Enrique Ortiz Rodriguez</i>	MEXICO	<i>Pia Palotie</i>	FINLAND
<i>Francesco Galati</i>	ITALY	<i>Pnina Shavit</i>	ISRAEL
<i>Halvard Øysæd</i>	NORWAY	<i>Priya Sharma</i>	UNITED STATES
<i>Helmut Woellik</i>	AUSTRIA	<i>Rong Huang</i>	UNITED KINGDOM
<i>Hiroyuki Obari</i>	JAPAN	<i>Rosa Cendros Araujo</i>	CANADA
<i>Ignacio Ballester</i>	SPAIN	<i>Sergio Pérez</i>	SPAIN
<i>Ignacio Candel</i>	SPAIN	<i>Shannon White</i>	UNITED KINGDOM
<i>Iván Martínez</i>	SPAIN	<i>Sylvia Dempsey</i>	IRELAND
<i>Jan Moritz Anke</i>	GERMANY	<i>Thomas Fischer</i>	GERMANY
<i>Jan Perry Evenstad</i>	UNITED STATES	<i>Valentina Donzella</i>	UNITED KINGDOM
<i>Jaroslav Kujawski</i>	POLAND	<i>Victor Harari</i>	MEXICO
<i>Javier Domenech</i>	SPAIN	<i>Wendy Gorton</i>	UNITED STATES
<i>Javier Martí</i>	SPAIN	<i>Xavier Lefranc</i>	FRANCE
<i>Joanna Lees</i>	FRANCE	<i>Xema Pedrós</i>	SPAIN
<i>John Craft</i>	UNITED STATES	<i>Yukio Konishi</i>	JAPAN

CONFERENCE SESSIONS

ORAL SESSIONS, 12th November 2018

Mobile Learning
Tutoring & Mentoring
ICT and Digital Skills among Teachers (1)
Work-Integrated Learning: University-Industry Collaboration
Technology Enhanced Learning (1)
Barriers to Learning and Social Inclusion
Learning Space Design
Special and Inclusive Education (1)
Maths and Statistics in Higher Education

Social Media and Social Networks in Education
Assessment of Student Learning (1)
ICT and Digital Skills among Teachers (2)
University-Industry Collaboration
Advanced Educational Technologies
Student Support and Engagement (1)
Architecture and Design Education
Special and Inclusive Education (2)
STEM Education (1)

Massive Open Online Courses & Open Educational Resources
Assessment of Student Learning (2)
Soft Skills Development
New challenges for the Higher Education Area
Active Learning Experiences in Higher Education
Student Support and Engagement (2)
3D Technologies and BIM in Architecture and Engineering
Dyslexia & Speech Learning Disorders
Computer Science Education (1)

e-Learning Experiences
e-Assessment
Information and Digital Literacy
Internationalization in Higher Education
Virtual Reality in Education
Quality Assurance in Higher Education
Business and Economics Education
Equity and Inclusive Education
Integrating Emerging Technologies and New Material with Design

POSTER SESSIONS, 12th November 2018

Pedagogical Methods and Innovations
Emerging Technologies in Education and Research

ORAL SESSIONS, 13th November 2018

Technology Enhanced Learning (2)
Serious Games & Game-Based Learning (1)
Community-Based Learning
Work-Integrated Learning, Research and Societal Impact
Project and Problem Based Learning (1)
Early Childhood Education
Pre-Service Teacher Education (1)
Pre-service Teacher Experiences in STEM
Language Learning Education

Learning Analytics
Serious Games & Game-Based Learning (2)
Community Engagement Education
Entrepreneur-ship Education
Technology for Active Learning
Curriculum Design Experiences
Pre-Service Teacher Education (2)
Maths in Primary and Secondary Education
Foreign Language Teaching and Learning (1)

Learning Management Systems (LMS)
Gamification
Sustainability Education
Work Employability
Experiential Learning
Management in Higher Education
Pedagogical Innovations & Educational Research
Computer Science Education (2)
Foreign Language Teaching and Learning (2)

Flipped Learning
Digital Skills and Student Support
Adult and Vocational Education
Workplace Learning
Collaborative and Peer-based Learning
Leadership and Management in Education
Teacher Training
Technology Enhanced Learning in STEM Education
Multicultural Education Challenges

Blended Learning
Creativity and Design Thinking in Education
Student Mental and Physical Well-being
Internships and Workplace Learning
Project and Problem Based Learning (2)
Experiences and Research in Education
Professional Development of Teachers
STEM Education (2)
Gender Issues in Education

POSTER SESSIONS, 13th November 2018

Global Issues in Education & Inclusive Learning

New Trends and Experiences in Education

VIRTUAL SESSIONS

21st Century Skills
Academic Research Projects
Accreditation and Quality in Education
Active and Experiential Learning
Adult Education
Advanced Classroom Applications and Technologies
Assessment of Student Learning
Assistive Technologies and Accessible Resources
Barriers to Learning
Blended Learning and Flipped Classroom
Bullying Prevention and Awareness
Collaborative and Problem-based Learning
Creativity and Design Thinking
Critical Thinking and Problem Solving
Curriculum Design
E-content Management and Development
e-Learning Experiences
Early Childhood Education
Educating Individuals with Intellectual Disabilities
Educating Individuals with Sensory and Motor Disabilities
Educating the Educators
Education for Sustainability
Education Practice Trends and Issues
Education, Research and Globalization
Emerging Technologies in Education
Emerging Technologies in Education and Research
Employability Issues and Trends
Flipped Learning
Game-based Learning and Gamification
Gender and Equality in Education
Global Issues in Education & Inclusive Learning
ICT and Digital Skills
In-service Teacher Training
Inclusive Learning, Cultural Diversity and Special Education
Informal Learning
International Projects
Language Learning Innovations
Leadership and Educational Management
Learning and Teaching Innovations
Learning Management Systems (LMS)
Life-long learning
Links between Education and Research
m-Learning: Mobile Applications and Technologies
Multicultural Inclusion and Indigenous Perspectives
New challenges for the Higher Education Area
New Challenges in Education and International Cooperation
New Trends and Experiences in Education
Online Assessment
Organizational, Legal and Financial Aspects
Pedagogical Innovations
Pedagogical Methods and Innovations
Post-graduate Education
Pre-service Teacher Experiences
Primary and Secondary Education
Professional Development of Teachers
Research Management
Research Methodologies
Research on Technology in Education
STEM Education Experiences
Student Support and Motivation
Technology in Teaching and Learning
Tutoring and Mentoring
Undergraduate Education
University Networks
University/Industry Experiences
Virtual Learning Environments (VLE)
Vocational Training
Work Employability
Workplace Learning

ABOUT ICERI2018 Proceedings

HTML Interface: Navigating with the Web browser

This USB Flash drive includes all presented papers at ICERI2018 conference. It has been formatted similarly to the conference Web site in order to keep a familiar environment and to provide access to the papers through your default Web browser (open the file named "ICERI2018_Proceedings.html").

An Author Index, a Session Index, and the Technical Program are included in HTML format to aid you in finding conference papers. Using these HTML files as a starting point, you can access other useful information related to the conference.

The links in the Session List jump to the corresponding location in the Technical Program. The links in the Technical Program and the Author Index open the selected paper in a new window. These links are located on the titles of the papers and the Technical Program or Author Index window remains open.

Full Text Search: Searching ICERI2018 index file of cataloged PDFs

If you have Adobe Acrobat Reader version 6 or later (www.adobe.com), you can perform a full-text search for terms found in ICERI2018 proceedings papers.

Important: To search the PDF index, you must open Acrobat as a stand-alone application, not within your web browser, i.e. you should open directly the file "ICERI2018_FrontMatter.pdf" with your Adobe Acrobat or Acrobat Reader application.

This PDF file is attached to an Adobe PDF index that allows text search in all PDF papers by using the Acrobat search tool (not the same as the find tool). The full-text index is an alphabetized list of all the words used in the collection of conference papers. Searching an index is much faster than searching all the text in the documents.

To search the ICERI2018 Proceedings index:

1. Open the Search PDF pane through the menu "Edit > Advanced Search" or click in the PDF bookmark titled "SEARCH PAPERS CONTENT".
2. The " ICERI2018_index.pdx" should be the currently selected index in the Search window (if the index is not listed, click Add, locate the index file .pdx, and then click Open).
3. Type the search text, click Search button, and then proceed with your query.

For Acrobat 9 and later:

1. In the "Edit" menu, choose "Search". You may receive a message from Acrobat asking if it is safe to load the Catalog Index. Click "Load".
2. A new window will appear with search options. Enter your search terms and proceed with your search as usual.

For Acrobat 8:

1. Open the Search window, type the words you want to find, and then click Use Advanced Search Options (near the bottom of the window).
2. For Look In, choose Select Index.
3. In the Index Selection dialog box, select an index, if the one you want to search is available, or click Add and then locate and select the index to be searched, and click Open. Repeat as needed until all the indexes you want to search are selected.
4. Click OK to close the Index Selection dialog box, and then choose Currently Selected Indexes on the Look In pop-up menu.
5. Proceed with your search as usual, selecting other options you want to apply, and click Search.

For Acrobat 7 and earlier:

1. In the "Edit" menu, choose "Full Text Search".
2. A new window will appear with search options. Enter your search terms and proceed with your search as usual.

PROMOTE LEARNING IN MECHANICAL TECHNOLOGY MANUFACTURING WORK EQUIPMENT

João E. Ribeiro^{1,2}, Paula Maria Barros¹, Flora Silva^{1,3}

¹*School of Technology and Management, Polytechnic Institute of Bragança (PORTUGAL)*

²*CIMO (PORTUGAL)*

³*FibEnTech (PORTUGAL)*

Abstract

Within the scope of the Mechanical Technology II course unit of the Degree in Mechanical Engineering of the Polytechnic Institute of Bragança (Portugal), it was proposed to carry out a practical work involving the design and manufacture of small teaching machines, specifically a hydraulic press (in the academic year 2015/2016) and a manual plate rolling machine (in the 2016/2017 academic year). Each work was carried out by a group of four students and was developed in four stages: project; manufacture; assembly and testing the machines; and writing a technical report. The students showed great enthusiasm for this type of work, which was even more evident in the stages of the manufacturing, assembly and testing the machines. In addition to improving the understanding of theoretical concepts by applying them to practice, it was also found that the level of self-confidence of students regarding contact and handling with industrial machines increased significantly.

Keywords: Mechanical technology, laboratory classes, didactic machines, hydraulic press, plate rolling machine.

1 INTRODUCTION

One of the main challenges of implementing the Bologna Process was to provide students with the role of protagonists in the process of teaching learning and to promote their autonomy with the planned follow-up of teachers [1]. In this perspective, according to Cunha [2], the methodologies to be adopted, within the scope of the engineering courses, should be directed towards the creation of learning environments that allow the student to "learn to learn", aiming at the development of competences that meet the requirements necessary for the future engineer.

The study plan of the degree in Mechanical Engineering of the School of Technology and Management of the Polytechnic Institute of Bragança (Portugal) includes the Mechanical Technology II course unit, which works in the second year of the course. At the end of their frequency in the course unit, students are expected to acquire basic knowledge about machining processes and sheet metal forming and cutting technology and have the ability to design and obtain parts using these procedures. They are also expected to gain basic knowledge about metal join processes: welding, soldering and adhesives joints.

As for the organization of the course unit, there is a theoretical component (theoretical classes, 2 hours per week) and a practical component (laboratory classes, 2 hours per week) and, traditionally, a teaching methodology with expository characteristics is followed. Although there is a more active participation of the students in the laboratory, it is still incipient because these classes are still very teacher-centered and, usually, the work with the machines is only done for a demonstrative purpose. In order to change this paradigm, in the academic years 2015/2016 and 2016/2017, the professor of the course unit decided that, although he/she maintained the format of the theoretical classes, for the advantage of approaching a great quantity of topics of interest in the scope of the course, laboratory classes would focus on actual work, at least for a selected group of students. The main objectives were to get students to apply theoretical knowledge in solving real problems and to make them learn how to use the laboratory's machine tools.

2 METHODOLOGY

Taking into account the objectives to be achieved, in the academic year 2015/2016 the design and manufacture of a hydraulic press was proposed and in the academic year 2016/2017 of a manual plate rolling machine. The hydraulic press is an equipment used to cut, bend and model materials, usually metallic [3]. The plate rolling machine is a machine that allows the bending of metal plates

between two or more cylinders [4]. The selection of the appropriate size for the equipment took into account the fact that it allows its construction by the students with the available means and, simultaneously, make possible its real use in the laboratory of Mechanical Technology for small work.

Four students participated in the experiment each year. In 2015/2016 the students were Spanish Erasmus (1 girl and 3 boys), who arrived at a later date than the beginning of the classes. In order for the students to recover the knowledge already covered during the time they were missing, it was considered pertinent that they develop a study that interconnected theoretical and practical contents, thus arising the proposal to design and manufacture a hydraulic press. As the students showed great enthusiasm in carrying out this work, in the following academic year, that is, in 2016/2017, it was decided to replicate the experience. Thus, when the work to be developed within the scope of the evaluation was presented to the class, the proposal for the creation of a manual plate rolling machine was also included. The students were previously advised that it was a job that needed some dedication and was demanding from the point of view of research and application of knowledge. The challenge was accepted by four Portuguese students, three boys and one girl, one of whom was motivated by feedback from the students who participated in the project the previous year.

The methodology followed in the classes was the same in both academic years. The students worked in groups and did the practical work throughout the semester. This was divided into four stages: design (drawing and dimensioning); manufacture; assembly and testing the machines and, at the end, the writing of a technical report.

In the part of the project the students drawing all the parts of the mechanism in a specialized Computer Aided Design (CAD) software called SolidWorks®. For the dimensioning of the mechanical elements, in a first phase, they used the specific equations that corresponded to them, being based on the consulted bibliography [5, 6]. In a second phase, they used the finite element module of the same software to simulate the mechanical behavior of the projected machines. The manufacturing of the non-standard parts of the machines was carried out in the mechanical technology laboratory of the institution using industrial machines, where the students were able to carry out most of the manufacturing operations with the assistance and follow-up of the laboratory technicians. Assembly and testing of the machine were developed in the same laboratory. The last stage of the work, that is, the writing of the technical report, was carried out by the students together. Based on this report, the students presented their classmates in the last class with the work done, focusing in particular on the description of the main phases of the work and the justification of the options taken.

The evaluation of the experience was made through the productions made by the students, both in the perspective of obtaining the final result (the machine) and in the intermediate documentation that they had to produce, and based on the field notes collected by the professor.

3 RESULTS

In this section we focus on the approaches taken in the various stages of the practical work and some of the difficulties of the students. Whenever pertinent, the information is supplemented with photographs clarifying the actions developed by the students.

3.1 Design and dimensioning

The design and dimensioning of the two machines began by defining their objectives and limits. Thus, it was intended to manufacture, for both cases, didactic mechanisms dedicated to the aid of small work in the laboratory. In this way, the hydraulic press would be used, essentially, for the placement of bearings while the plate rolling machine would be used to bend sheet of small thickness and dimensions. For the characteristics of the equipment defined, it is concluded that the workloads involved would have a low intensity, so that their structure would be relatively light.

After defining the objectives and limits, the design and sizing phase of the machines was started. As previously mentioned, the drawings were made in a CAD software which allows to create a three-dimensional model of each of the pieces and, later, to assembly them to obtain the complete machine. In Fig. 1 it is possible to observe, by way of example, an exploded view of the hydraulic press drawn in SolidWorks®.

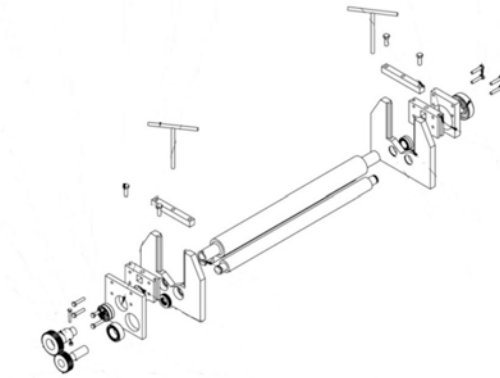

Figure 1. Draw of the manual rolling machine.

The dimensioning of the structure and the mechanical elements was based on the dimensions defined for the equipment and taking into account the design calculations defined in the specialized bibliography [5, 6]. Thus, for example, in the case of calculating the force for bending a plate in the plate rolling machine the students used equation:

$$F_c = \frac{\sigma_y \times b \times h^2}{d}$$

where F_c is the force required to bend the plate in the plate rolling machine, σ_y is the yield stress, b is the length of the sheet, h is its thickness and d is the distance between the contact surfaces.

With regard to the design of machines, in recent years numerical tools have been increasingly used, as is the case with the finite element method [7]. Thus, to verify if the structural dimensioning was correct, we used the finite element module of SolidWorks, which allowed to simulate the behavior of the structure of the machines when they are in operation. Fig. 2 shows the results of the simulation performed by the students for the hydraulic press.

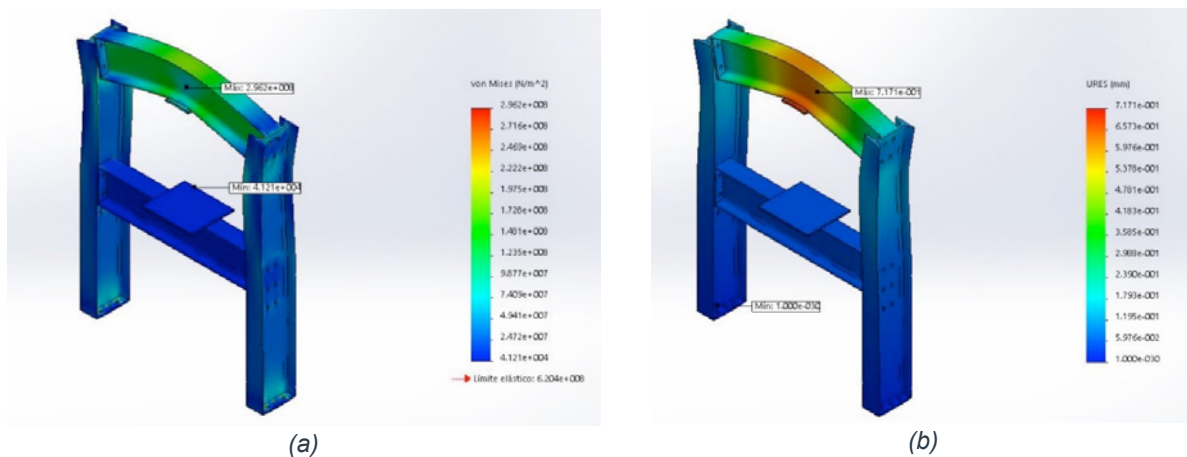

Figure 2. Von-Mises stresses (a) and global displacement (b) in structure due to work load.

The standard elements, such as screws, bearings and gears, were dimensioned according to the calculation procedures defined in the specialized bibliography referred to above.

Regarding the difficulties of the students in this stage, regarding the dimensioning, they focused on the selection of the most adequate equations for the sizing of the various mechanical elements.

In working with SolidWorks students demonstrated that they did not have difficulties in the CAD module, in which they had to make the drawings of the machine, probably because they had already worked on this module in the context of other curricular units. However, in the FEM (Finite Element Method) module, used for the numerical simulation of the mechanical behavior of the machines structural elements, the students' difficulties in operating with the software were evident in order to respond to what they wanted, as well as the lack of theoretical and practical knowledge regarding the finite element method. Difficulties that can be explained by the fact that the students have not yet

studied these subjects in depths in the other curricular units. However, these difficulties were overcome through the study and consultation of specialized manuals [8] and websites related to SolidWorks.

3.2 Manufacturing the machine elements

After the project execution, the students manufactured the non-standard components in the laboratory, using industrial machine tools (milling machine, lathe, drilling machine, among others) that use chipper manufacturing processes. In these manufacturing processes, the workpiece, corresponding to metallic blocks (cylindrical or parallelepiped), and small metallic chips of material are removed until obtaining a final product. In the manufacture of the hydraulic press, besides chipper manufacturing processes, welding processes were also used.

The construction of the hydraulic press structure involved the use of steel profiles that had to be cut into a mechanical saw. As a set of mechanical elements would have to be coupled, it was necessary to machine some punches and holes in the steel profiles. For this purpose, two machine tools were used, a vertical milling machine to create the traces and a radial boring machine to make the holes. After this manufacturing phase, the structural elements were connected together by the MAG (Metal Active Gas) welding process. It was also necessary to manufacture some steel plate supports that were obtained by the mechanical guillotine cutting process. As these supports were pierced, the radial drilling machine was again used. Finally, the last element to be manufactured was a steel shaft that would be used as a pawl for the height positioning of the press table. This element was obtained by machining process using the lathe.

The manufacture of the plate rolling machine involved only machining processes using three types of machine tools, depending on the geometry of the workpiece to be manufactured. Thus, pieces with geometry of revolution (cylindrical rollers) were manufactured in the lathe. In order to execute the flat parts (plates, supports, sliding side supports) the milling machine was used, also the drill was used to machine the holes in these elements. Fig. 3 shows illustrative elements of some phases of the manual manufacture of plate rolling machine.



Figure 3. Mechanical parts manufacturing using: lathe process (a) and milling process (b).

3.3 Assembly and machine testing

At this stage, in addition to the parts previously manufactured by the students, it was necessary to acquire, in specialized stores, the standard elements defined in the design phase, namely, bearings, gears, screws, nuts, among others.

The elements were all assembled according to the set design carried out in the project and with the support of small tools. In the particular case of plate rolling machine, the bearings and bushings were mounted on the structure with the help of the hydraulic press manufactured in the previous year. Fig. 4 shows the two machines built by the students.



(a)

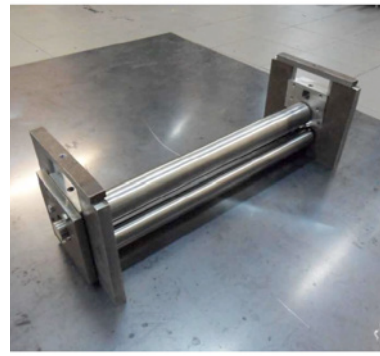

(b)

Figure 4. The hydraulic press (a) and the manual rolling machine (b) after the assembly process.

After the assembly and fixation of all the mechanical and structural elements of the machines, their operation was tested and the need to make small adjustments or the manufacture of new elements were evaluated.

Thus, in the case of the hydraulic press, it was important that it had a high flexibility, however, in a laboratory of mechanical technology is very often used for the assembly and disassembly of bearings in holes or cavities, as this operation is carried out with tightening, requiring an extremely precise procedure involving relatively high forces and, hence, the need to use a press. In this sense, the students performed some experimental tests of assembly of bearings in wells with different values of interference. The tests were successful, with five bearings mounted without any deterioration or misalignments.

In order to test the manual rolling machine several bends of sheet with different thicknesses, from 0.6 mm to 3 mm, were performed, the latter corresponding to the maximum thickness that the machine could bend. As can be seen from Fig. 5, it was possible to successfully bend the different thicknesses tested.



(a)



(b)

Figure 5. Testing the manual rolling machine (a) and the obtained results of bending steel sheet with different thicknesses (b).

3.4 Technical report

The technical report was written in a group by the four students and written in their mother tongue. Thus, in the academic year 2015/2016 was written in Castilian while in the academic year 2016/2017 was written in Portuguese, however in both reports it was mandatory to include a summary in English. The students organized it into six chapters: the introduction, which included the objectives of the work; the theoretical basis; mechanical design; the experimental procedure corresponding to the description of the manufacture, assembly and tests carried out; analysis and discussion of results and conclusions.

This phase was less exciting for the students and in which there were many difficulties. These difficulties centered on failures in the ability of students to express their ideas in a clear, concise and structured manner. There were also gaps in the grammatical structure of sentences and some misspellings. However, the professor suggested some changes, corrections and improvements in the

written report, which the students took into consideration and the revised report improved significantly when compared to the first version.

4 CONCLUSIONS

In both academic years, the students who participated in the experiment were motivated and committed throughout the process, although they had some difficulties, for example, in the use of software and in working with industrial machines.

Regarding SolidWorks software, the students demonstrated good knowledge and ability to work with the CAD module when designing the machines, but they had considerable difficulties in the FEM module for the numerical simulation of the mechanical behavior of the structural elements of the machines. However, these difficulties turned out to be an added value for the students' learning, since it was necessary to overcome them in order to carry out the work, this made them to improve their knowledge about the finite element method and to research as operate with the software to meet the challenge that has been proposed to them.

In the initial phase of the manufacture of the pieces of the designed machines, the students had some difficulty and fear in using the industrial machines, which is justified by their little experience in the contact with this type of machines. However, most of these difficulties were overcome by consulting the existing bibliography (internet, books / manuals) and the support of the teacher and laboratory technicians.

The work done, in addition to allowing students to better understand the theoretical concepts, because they had to apply them in practice, also made them more responsible and made them develop their communication skills and collaboration with peers. There was also an increase in the level of self-confidence of the students to carry out more practical work, as well as in the handling of industrial machines. I gain that will be an asset for a future mechanical engineer, to the extent that the professional level may have to deal with this type of contexts and equipment.

REFERENCES

- [1] K. Caballero, A. Bolívar, "El professorado universitario como docente: hacia una identidad profesional que integre docencia e investigación," *Revista de Docencia Universitaria*, vol. 13, no. 1, pp. 57-77, 2015.
- [2] F.M. Cunha, "Ensino de engenharia: abordagem pela complexidade," *Revista de Ensino de Engenharia*, vol. 34, no. 1, pp. 3-16, 2015.
- [3] V. Boljanovic, *Sheet Metal Forming Processes na Die Design*. New York: Industrial Press Inc., 2004.
- [4] T. Altan, A. E. Tekkaya, *Sheet Metal Forming: Processes and Applications*. Ohio: ASTM International, 2012.
- [5] R.G. Budynas, J.K. Nisbett, *Shigley's Mechanical Engineering Design*. New York: McGraw-Hill, 2006.
- [6] A.C. Ugural, *Mechanical Design: An Integrated Approach*. New York: McGraw-Hill, 2004.
- [7] R. C. Cook, *Finite Element Modeling for Stress Analysis*. Toronto: John Wiley & Sons Inc., 1995.
- [8] P. M. Kurowski, *Engineering Analysis with SOLIDWORKS Simulation 2015*. New York: Stephen Schoff, 2015.
- [9] SolidWorks, available: <https://www.solidworks.com>.