

Call for Registration



Designing Structures for Fire

September 30 - October 1, 2003
Radisson Plaza Lord Baltimore
Baltimore, MD

Co-Sponsored by:



Society of Fire Protection Engineers
Bethesda, MD USA

Structural Engineering Institute
Reston, VA USA



Conference Web Page: <http://www.sfpe.org> under the Education & Special Events tab.

About the Conference

Designing Structures for Fire serves as a forum for exchange on recent advancements among researchers, practicing engineers in fire protection, structures and materials, architects and regulators. By reaching a broad audience, the conference will facilitate coordination and understanding between these groups and drive the practical application of cutting edge research.

The first day of the conference will be dedicated to failure analysis, fire resistance evaluation of structural members in steel, and alternatives to U.S. codes. On the second day, the theme of the conference will turn to fire resistance evaluation of structural members in concrete, wood, gypsum, analytical approach to design methods for structural response to fire, and real building case studies. In all, 29 papers representing 12 countries from around the world will be presented.

Hotel Information

The conference hotel is the *Radisson Plaza Lord Baltimore Hotel*, 20 West Baltimore Street, Baltimore, MD 21201-3203. The conference sessions will be held in the Baltimore Audiovisual Theatre in the hotel. The hotel telephone number is 1(800) 333-333 or (410) 539-8400. The conference room rate for a single/double is \$150.00, plus applicable taxes.

Reservations must be made by **September 5, 2003** in order to receive the SFPE room rate and to be assured of room availability. Individuals are responsible for making their own reservations. When making your reservation, please state you are part of the *Society of Fire Protection Engineers Group*.

Registration

On-site Registration: On-site registration will begin on Tuesday, September 30, 2003 from 7:30 a.m. until 4:00 p.m. and continues each morning at 7:30 a.m.

How to Register: Register on-line at www.sfpe.org under the Education & Special Events tab, or mail the completed registration form on the back of this brochure with check or credit card information to: SFPE, 7315 Wisconsin Avenue, Suite 1225W, Bethesda, MD 20814 or fax the completed registration form with credit card payment to: +301 718-2242. Note, if you are faxing your form, do not mail the original form. Reminder: please use a separate form for each registrant, photocopy if necessary. Type or print clearly.

Other SFPE Events: *Designing Structures for Fire* will be held during the SFPE Annual Meeting and Professional Development Conference. This event will start on Monday, September 29 and includes a complimentary one day professional program with the latest updates on the science and practice of fire protection engineering, the professional issues of concern to the practicing FPE, as well as the familiar ice cream social. This will be followed by the traditional Awards and Honors Banquet, and by four days of education events, including 6 seminars. Visit the SFPE website for more detailed information. *Register for one educational event and receive a 50% discount on the registration for additional (less expensive) events.*

SFPE's Cancellation Policy: *Cancellations must be in writing.* A full refund of registration fees may be obtained if SFPE receives written notification of your cancellation within seven (7) days of the event. All other cancellations are subject to a \$75.00 fee. "No Shows" are ineligible for refunds. SFPE reserves the right to cancel any education event that is under-subscribed.

Social Program

A Welcoming Reception will be held on Tuesday, September 30, 2003 at 1700.

Special Requirements

If you have any special requirements due to disability or special dietary needs, such as: vegetarian, pork, shell fish, etc., please contact SFPE Headquarters or indicate your requirement on the registration form.

PROGRAM

Tuesday, September 30, 2003

0800 – 0815 **Welcome:** Barbara Lane, United Kingdom

Failure Analysis of the World Trade Center Structure

Moderator: William F. Baker, P.E., S.E., Skidmore Owings & Merrill, LLP, United States

0815 – 0845 *Anatomy of the World Trade Center Collapses: A Structural Engineering Investigation*, N. N. Abboud and M. P. Levy, United States

0845 – 0915 *An Assessment of the Stability of the World Trade Center Twin-Towers in a Major Fire*, A. Usmani, Y.C. Chung and J. Torero, United Kingdom

0915 – 0945 *The Behaviour of Lightweight Composite Floor Trusses in Fire*, S. K. Choi, I. Burgess and R. Plank, United Kingdom

0945 – 1015 Break

Fire Analysis

Moderator: Thomas Izbicki, P.E. Dallas Fire-Rescue Department, United States

1015 – 1045 *Heat Transfer by Radiation in Internal Cavities with a Complex Shape*, J.M. Franssen, Belgium

1045 – 1115 *The Prediction of Thermal Loading for Structural Analysis Under Fire Exposure*, W. Zhang, D. J. Carpenter and R. J. Roby, United States

1115 – 1145 *Design Fires for Structural Performance*, R.W. Fitzgerald and L.D. Albano, United States

1145 – 1215 *Analysis of Fire Development in the World Trade Center Attacks*, C. L. Beyler, United States

1215 – 1315 Lunch

Fire Resistance Evaluation of Structural Members

Moderator: Venkatesh Kodur, Ph.D., P.Eng., National Research Council, Canada

1315 – 1345 *Durability of Fire-Resistance Coatings*, W. A. Webb, United States

1345 – 1415 *Value of Fire Resistance Testing*, R. M. Berhinig and J. A. Treadway, United States

1415 – 1445 *Buckling Strength of Steel Columns with Induced Deformation at Increasingly Higher Temperatures*, T. Okabe and T. Ave, Japan

1445 – 1515 Break

Alternatives to U.S. Codes

Moderator: James A. Milke, Ph.D., P.E., University of Maryland, United States

1515 – 1545 *Probabilistic Models for Fire Resistance Evaluation*, G. Ramachandran, United Kingdom

1545 – 1615 *Performance-based Design of Office Buildings Using the Equivalent Time Method*, P. Schaumann and A. Heise, Germany

1615 – 1645 *How to Use a Scale Model to Simulate the Fire and Structural Failure*, J. G. Quintiere, United States

1645 – 1715 *Current Developments in the Structural Fire Protection Engineering Profession*, K. Almand and M. Hurley, United States

Welcome Reception.

A Reception will be held on Tuesday, 30 September at 1700. All delegates and accompanying persons are invited to attend.

Wednesday, October 1, 2003

Fire Resistance Evaluation of Structural Members: Concrete, Wood, and Gypsum

Moderator: Walter W. Jones, Ph.D., National Institute of Standards and Technology, United States

- 0800 – 0830 *Application of Idealized Materials Data for Calculation of Fire Exposed Concrete Constructions*, K. D. Hertz, Denmark
- 0830 – 0900 *Investigation of Spalling in High Performance Concrete*, R. C. Lima, L. C. Silva Filho, and F. P. Gastal, Brazil
- 0900 – 0930 *Fire Resistance Design Guidelines for High Strength Concrete Columns*, V. Kodur, Canada
- 0930 – 1000 Break

Moderator: Prof. dr. ir. Jean-Marc Franssen, University of Liege, Belgium

- 1000 – 1030 *Engineering Analysis of Gypsum Board Ceiling Membranes at Elevated Temperatures*, S. M. Cramer, G. Sriprukiat and R. H. White, United States
- 1030 – 1100 *Mechanical Properties of Fibre Reinforced Polymer Reinforcing Bars at Elevated Temperature*, Y. C. Wang, P. M. H. Wong, and V. Kodur, United Kingdom and Canada
- 1100 – 1130 *Self Compacting Concrete Exposed to Fire*, L. Bostrom, Sweden
- 1130 – 1200 *Fire Resistance Performance of Lightweight Floor Assemblies*, M. A. Sultan, Canada
- 1200 – 1300 Lunch

Analytical Approach to Design Methods for Structural Response to Fire

Moderator: Paul D. Sullivan, P.E., Robert W. Sullivan, Inc., United States

- 1300 – 1330 *Ultimate Capacity of Composite Floor Slabs at the Fire Limit State*, N. J. K. Cameron and A. S. Usmani, United Kingdom
- 1330 – 1400 *Effect of Support Stiffness on Axial Forces in Partially Restrained Composite Beams in Real Fires*, J. Chang, A. Buchanan, and P. J. Moss, New Zealand
- 1400 – 1430 *Connections and the Stability Behavior of Steel Frames Under Fire Conditions*, A. Masarira, South Africa
- 1430 – 1500 *Numerical Modelling of the Fire Resistance of Steel I-Beams with Restrained Thermal Elongation*, P. Vila Real, L. Simoes de Silva, and P. Piloto, Portugal
- 1500 – 1530 Break

Real Building Designs: Case Studies

Moderator: Barbara Lane, Ph.D., ArupFire, United Kingdom

- 1530 – 1600 *Practical Case Studies in Performance-Based Structural Fire Engineering Design*, M. Green, N. Butterworth, I. Burgess and R. Plank, United Kingdom
- 1600 – 1630 *Structural Behaviour in Fire and Real Design*, S. Lamont, United Kingdom
- 1630 – 1700 *Achieving Robustness Through Performance-Based Structural Fire Engineering*, D. Robertson, M. Feeney and E. Velivasakis, United States and New Zealand
- 1700 – 1730 *Fire Life Safety Design for the New Seven World Trade Center*, C. Galiota, United States



REGISTRATION FORM



Please complete this form and return it to:

Designing Structures for Fire

Society of Fire Protection Engineers

7315 Wisconsin Avenue, Suite 1225W, Bethesda, MD 20814

(301) 718-2910 or (301) 718-2242 or register at www.sfpe.org

NAME (First) (Initial) (Last)

ORGANIZATION TITLE

ADDRESS

CITY/TOWN PROV/STATE POSTAL CODE

COUNTRY

TELEPHONE FAX EMAIL

NICKNAME (*Bud, Jim, etc.*)

SPECIAL REQUIREMENTS (*Dietary or Accessibility*)

Advance Registration Fees: (Must be received by August 29, 2003)

- \$350.00 SFPE/SEI/ASCE Member \$450.00 Non-member

Late Registration Fees: (Received after August 29, 2003)

- \$455.00 SFPE/SEI/ASCE Member \$550.00 Non-member

This section must be completed to receive member discount:

- SFPE Member - My member number is _____ (*Must have to receive discount*)
 SEI/ASCE - My member number is _____ (*Must have to receive discount*)
 Non-member

Method of Payment:

☆ Enclosed is my check -- payable to "SFPE"

☆ Please charge my: American Express MasterCard Visa

Card Number Expiration Date

Name as on Card Signature

Payment Must Accompany the Registration Form



SFPE Educational and Scientific Foundation
7315 Wisconsin Avenue, Suite 1225W
Bethesda, MD 20814

Numerical Modelling of the Fire Resistance of Steel I-beams with Restrained Thermal Elongation

Vila Real, P. M. M.^{a *}, Simões da Silva, L.^b, Lopes, N.^c, Piloto, P.^d

^{a, c} Department of Civil Engineering, University of Aveiro, 3810 Aveiro, Portugal
Tel.: +351-234-370049; fax: +351-234-370094; e-mail: pvreal@civil.ua.pt

* Corresponding author

^b Department of Civil Engineering, University of Coimbra, 3030-290 Coimbra, Portugal

^d Department of Mechanical Engineering, Polytechnic of Bragança, Bragança, Portugal

ABSTRACT

In this paper the influence of the restrained thermal elongation in the behaviour of steel I-beams being part of a frame has been studied.

In fact there is a significant difference between the case of a beam acting as a single element free to exhibit axial thermal elongation or being part of a frame where the stiffness of the remaining structure contributes with some restraint to the free elongation of the beam.

A numerical study of the behaviour of steel I-beams subjected to fire and a combination of axial force and bending moments has been presented. A geometrical and material non-linear finite element program, specially established at the University of Liege for the analysis of structures submitted to fire, has been used to determine the resistance of a beam-column at elevated temperature, using the material properties of Eurocode 3, part 1-2. The numerical results have been compared with those obtained with the Eurocode 3, part 1-2 (1995) and the new version of the same Eurocode (2002).

The results have confirmed that the new proposal for Eurocode 3 (2002) is more conservative than the ENV-EC3 (1995) approach.

Key words: beam-column, buckling, torsional-buckling, fire, Eurocode 3, numerical modelling

1. INTRODUCTION

Under fire conditions, axially and eccentrically loaded columns were studied by Franssen et al [1-3] for the cases where the failure mode is in the plane of loading, who proposed a procedure for the design of columns under fire loading, later adopted by EC3 [4]. Analogously, Vila Real et al [5-7] studied the problem of lateral torsional buckling of beams under fire loading, and equally proposed a design expression also adopted by EC3 [4].

The 3D behaviour of members submitted to combined moment and axial loads, i.e. the interaction between bending, buckling and lateral torsional buckling, was never specifically studied and it is thus impossible to establish the level of safety and accuracy provided by the current design proposals. It is the objective of the present paper to address this issue, using a numerical approach. The program SAFIR [8] was chosen to carry out the numerical simulations, which is a finite element code for geometrical and material non-linear analysis, specially developed for studying structures in case of fire.

2. CASE STUDY

A simply supported beam with fork supports was chosen to explore the validity of the beam-column safety verifications, loaded with moments in the major axis and axial compression (Fig.1). Regarding the bending moment variation along the member length, three values of the ψ ratio (-1, 0, 1) have been investigated. An IPE 220 of steel grade S 235 was used, with a uniform temperature distribution in the cross section.

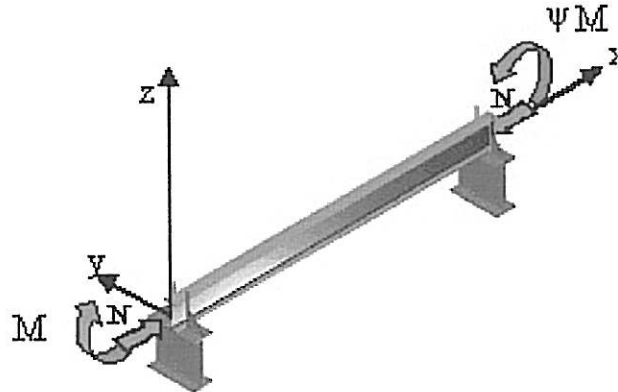

Fig. 1 – Simply supported beam with bending and axial compression.

A lateral geometric imperfection given by the following expression was considered:

$$y(x) = \frac{l}{1000} \sin\left(\frac{\pi x}{l}\right) \quad (1)$$

Finally, the residual stresses adopted are constant across the thickness of the web and of the flanges. Triangular distribution as in figure 2, with a maximum value of 0.3×235 MPa, for the S235 steel has been used [9].

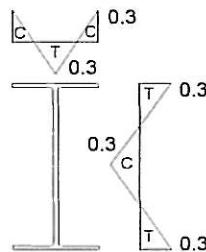

Fig.2 – Residual stresses: C – compression; T – tension

3. THE EUROCODE MODELS FOR BENDING AND AXIAL FORCE UNDER FIRE LOADING

3.1 Simple model according to Eurocode 3 (1995)

According to part 1-2 of the Eurocode 3 [10], elements with cross-sectional classes 1 and 2 submitted to bending and axial compression, in case of fire, must satisfy the following condition:

$$\frac{N_{fi,Ed}}{\frac{\chi_{min,fi}}{1.2} A k_{y,0} \frac{f_y}{\gamma_{M,fi}}} + \frac{K_y M_{y,fi,Ed}}{W_{pl,y} k_{y,0} \frac{f_y}{\gamma_{M,fi}}} \leq 1 \quad (2)$$

where

$$K_y = 1 - \frac{\mu_y N_{fi,Ed}}{\frac{\chi_{y,fi}}{1.2} Ak_{y,\theta} f_y} \quad \text{but } K_y \leq 1.5 \quad (3)$$

and

$$\mu_y = \bar{\lambda}_{y,\theta} (2\beta_{M,y} - 4) \left[\frac{W_{pl,y} - W_{el,y}}{W_{el,y}} \right] \quad \text{but } \mu \leq 0.9 \quad (4)$$

where

$\chi_{\min,fi}$ is the minimum reduction factor of the axis yy and zz ;

$W_{pl,y}$ is the plastic modulus in axis yy ;

$k_{y,\theta}$ is the reduction factor of the yield strength at temperature θ

$\gamma_{M,fi}$ is the partial safety coefficient in case of fire (usually $\gamma_{M,fi} = 1$);

$\beta_{M,y}$ is the equivalent uniform moment factor, in this case ($\beta_{M,y} = 1.1$);

The reduction factor is calculated with the expressions from the part 1.1 of Eurocode 3 [11]. The reduction factor in case of fire, $\chi_{y,fi}$ and $\chi_{z,fi}$, are determined as for room temperature using the slenderness $\bar{\lambda}_{y,\theta}$ e $\bar{\lambda}_{z,\theta}$ given by equation (5). The constant 1.2 is an empirical correction factor. In the calculation of the reduction factor in case of fire, the buckling curve used is the curve c ($\alpha=0.49$).

$$\bar{\lambda}_{y,\theta} = \bar{\lambda}_y \sqrt{\frac{k_{y,\theta}}{k_{E,\theta}}} \quad \bar{\lambda}_{z,\theta} = \bar{\lambda}_z \sqrt{\frac{k_{z,\theta}}{k_{E,\theta}}} \quad (5)$$

where:

$\bar{\lambda}_y$ and $\bar{\lambda}_z$ are the slenderness of the axis yy and zz at room temperature;

$k_{E,\theta}$ is the reduction factor of the elastic modulus at temperature θ .

The following values are also defined:

$$N_{fi,\theta,Rd} = Ak_{y,\theta} \frac{f_y}{\gamma_{M,fi}} \quad M_{y,fi,\theta,Rd} = W_{pl,y} k_{y,\theta} \frac{f_y}{\gamma_{M,fi}} \quad (6a,b)$$

In order to compare results, the maximum value of the design moment is divided by the plastic moment resistance at temperature θ . Solving equation (2) for $M_{y,fi,Ed}$ and dividing by $M_{y,fi,\theta,Rd}$ from equation (6), yields

$$\frac{M_{y,fi,Ed}}{M_{y,fi,\theta,Rd}} \leq \frac{1}{\left(1 - \frac{\mu_y N_{fi,Ed}}{\frac{\chi_{y,fi}}{1.2} N_{fi,\theta,Rd} \gamma_{M,fi}} \right)} \left(1 - \frac{N_{fi,Ed}}{\frac{\chi_{\min,fi}}{1.2} N_{fi,\theta,Rd}} \right) \quad (7)$$

In addition, also from part 1.2 of EC3 [10], a second condition related to lateral-torsional buckling is also required, and the following formula must also be verified:

$$\frac{N_{fi,Ed}}{1.2 Ak_{y,\theta} \frac{f_y}{\gamma_{M,fi}}} + \frac{K_{LT} M_{y,fi,Ed}}{1.2 W_{pl,y} k_{y,\theta} \frac{f_y}{\gamma_{M,fi}}} \leq 1 \quad (8)$$

with

$$K_{LT} = 1 - \frac{\mu_{LT} N_{fi,Ed}}{\frac{\chi_{z,fi}}{1.2} Ak_{y,\theta} f_y} \quad \text{but} \quad K_{LT} \leq 1.0 \quad (9)$$

and

$$\mu_{LT} = 0.15 \bar{\lambda}_{z,\theta} \beta_{M,LT} - 0.15 \quad \text{but} \quad \mu \leq 0.9 \quad (10)$$

where

$\beta_{M,LT}$ is the equivalent uniform moment factor corresponding to lateral-torsional buckling, in this case ($\beta_{M,LT} = \beta_{M,y} = 1.1$);

The reduction factor for lateral-torsional buckling is calculated according to the expressions of Eurocode 3, if the slenderness $\bar{\lambda}_{LT,\theta}$ at the temperature θ exceeds 0.4. The reduction factor in case of fire, $\chi_{LT,fi}$, is determined as for room temperature using the slenderness $\bar{\lambda}_{LT,\theta}$ given by:

$$\bar{\lambda}_{LT,\theta} = \bar{\lambda}_{LT} \sqrt{\frac{k_{y,\theta}}{k_{E,\theta}}} \quad (11)$$

Again, in order to compare the results, the maximum value of the design moment is divided by the plastic moment resistance at temperature θ . Solving for $M_{y,fi,Ed}$ from equation (8) and dividing by $M_{y,fi,\theta,Rd}$ from equation (6), gives

$$\frac{M_{y,fi,Ed}}{M_{y,fi,\theta,Rd}} \leq \frac{\chi_{LT}}{1.2 \left(1 - \frac{\mu_{LT} N_{fi,Ed}}{\frac{\chi_{z,fi}}{1.2} N_{fi,\theta,Rd} \gamma_{M,fi}} \right)} \left(1 - \frac{N_{fi,Ed}}{\frac{\chi_{z,fi}}{1.2} N_{fi,\theta,Rd}} \right) \quad (12)$$

3.2 Simple model according to the new version of Eurocode 3 (2002)

According to the new version of Eurocode 3 [4] the elements with cross-sectional classes sections 1 and 2 subjected to bending and axial compression, in case of fire, must satisfy the condition:

$$\frac{N_{fi,Ed}}{\chi_{\min,fi} Ak_{y,\theta} \frac{f_y}{\gamma_{M,fi}}} + \frac{K_y M_{y,fi,Ed}}{W_{pl,y} k_{y,\theta} \frac{f_y}{\gamma_{M,fi}}} \leq 1 \quad (13)$$

where

$$K_y = 1 - \frac{\mu_y N_{fi,Ed}}{\chi_{y,fi} A k_{y,\theta} \frac{f_y}{\gamma_{M,fi}}} \quad \text{but} \quad K_y \leq 3 \quad (14)$$

and

$$\mu_y = (1.2\beta_{M,y} - 3)\bar{\lambda}_{y,\theta} + 0.44\beta_{M,y} - 0.29 \quad \text{but} \quad \mu \leq 0.8 \quad (15)$$

with

$$\chi_{fi} = \frac{1}{\phi_\theta + \sqrt{[\phi_\theta]^2 - [\bar{\lambda}_\theta]^2}} \quad (16)$$

where

$$\phi_\theta = \frac{1}{2} \left[1 + \alpha \bar{\lambda}_\theta + (\bar{\lambda}_\theta)^2 \right] \quad (17)$$

and

$$\alpha = 0.65 \sqrt{235/f_y} \quad (18)$$

χ_{fi} is the reduction factor to the axis yy and zz in case of fire;

$$\bar{\lambda}_{y,\theta} = \bar{\lambda}_y \sqrt{\frac{k_{y,\theta}}{k_{E,\theta}}} \quad \bar{\lambda}_{z,\theta} = \bar{\lambda}_z \sqrt{\frac{k_{y,\theta}}{k_{E,\theta}}} \quad (19a,b)$$

where:

$\bar{\lambda}_y$ and $\bar{\lambda}_z$ are the slenderness of the axis yy and zz at room temperature;

$k_{E,\theta}$ is the reduction factor of the elastic modulus at temperature θ

Following the same strategy as before, solving for $M_{y,fi,Ed}$ from equation (13) and dividing by $M_{y,fi,\theta,Rd}$ from equation (6), yields the ratio of applied moment versus resisting moment for a given level of axial force:

$$\frac{M_{y,fi,Ed}}{M_{y,fi,\theta,Rd}} \leq \frac{1}{\left(1 - \frac{\mu_y N_{fi,Ed}}{\chi_{y,fi} N_{fi,\theta,Rd}} \right)} \left(1 - \frac{N_{fi,Ed}}{\chi_{\min,fi} N_{fi,\theta,Rd}} \right) \quad (20)$$

Again, the lateral-torsional buckling check is given by

$$\frac{N_{fi,Ed}}{\chi_{z,fi} A k_{y,\theta} \frac{f_y}{\gamma_{M,fi}}} + \frac{K_{LT} M_{y,fi,Ed}}{\chi_{LT,fi} W_{pl,y} k_{y,\theta} \frac{f_y}{\gamma_{M,fi}}} \leq 1 \quad (21)$$

where

$$K_{LT} = 1 - \frac{\mu_{LT} N_{fi,Ed}}{\chi_{z,fi} A k_{y,\theta} \frac{f_y}{\gamma_{M,fi}}} \quad \text{but} \quad K_{LT} \leq 1.0 \quad (22)$$

and

$$\mu_{LT} = 0.15 \bar{\lambda}_{z,\theta} \beta_{M,Lt} - 0.15 \quad \text{but} \quad \mu \leq 0.9 \quad (23)$$

where

$\beta_{M,LT}$ is the equivalent uniform moment factor corresponding to lateral-torsional buckling, in this case ($\beta_{M,LT} = \beta_{M,y} = 1.1$);

where

$$\chi_{LT,\beta} = \frac{1}{\phi_{LT,\theta} + \sqrt{[\phi_{LT,\theta}]^2 - [\bar{\lambda}_{LT,\theta}]^2}} \quad (24)$$

with

$$\phi_{LT,\theta} = \frac{1}{2} \left[1 + \alpha \bar{\lambda}_{LT,\theta} + (\bar{\lambda}_{LT,\theta})^2 \right] \quad (25)$$

$$\alpha = 0.65 \sqrt{235/f_y} \quad (26)$$

$$\bar{\lambda}_{LT,\theta} = \bar{\lambda}_{LT} \sqrt{\frac{k_{y,\theta}}{k_{E,\theta}}} \quad (27)$$

Similarly, for comparison, the maximum value of the design moment (taken from equation (21)) is divided by the plastic moment resistance at temperature (equation (6)), to give

$$\frac{M_{y,\beta,Ed}}{M_{\beta,\theta,Rd}} \leq \frac{\chi_{LT}}{\left(1 - \frac{\mu_{LT} N_{\beta,Ed}}{\chi_{z,\beta} N_{\beta,\theta,Rd}} \right)} \left(1 - \frac{N_{\beta,Ed}}{\chi_{z,\beta} N_{\beta,\theta,Rd}} \right) \quad (28)$$

4. COMPARATIVE ANALYSIS OF THE NUMERICAL RESULTS AND THE TWO VERSIONS OF EUROCODE 3

4.1 Basic results: steel members loaded in compression or in bending

To establish the grounds for the subsequent analysis of the behaviour of beam-columns, it is worth recalling the results of axially-compressed columns and simply-supported beams loaded in pure bending under fire conditions.

For both versions of part 1.2 of Eurocode 3, figure 3 compares the axial resistance of an axially-compressed pin-ended column, non-dimensionalised with respect to its plastic resistance, for a range of non-dimensional slenderness, $\bar{\lambda}_{\theta,com}$, with the corresponding numerical results for various constant temperature simulations (400° to 700°C). It is noted that, although the numerical results apparently highlight a slight unconservative nature of the eurocode design expressions, experimental results indicate otherwise, an issue briefly discussed in the conclusions.

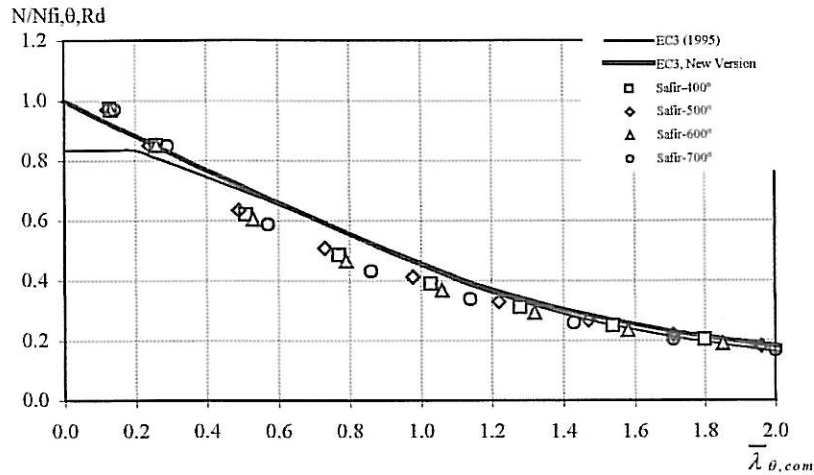

Fig. 3 – Design curves for buckling of columns

Analogously, figures 4, 5 and 6 compare the non-dimensional bending resistance of a simply supported beam under bending moment variation along its length according to the three values of the ψ ratio (-1, 0, 1) from the two eurocode proposals, against the numerical results obtained using the program SAFIR for a range of uniform temperatures from 400° to 700°C, for various levels of non-dimensional slenderness, $\bar{\lambda}_{LT,\theta,com}$. For $\psi = 1$, the more recent

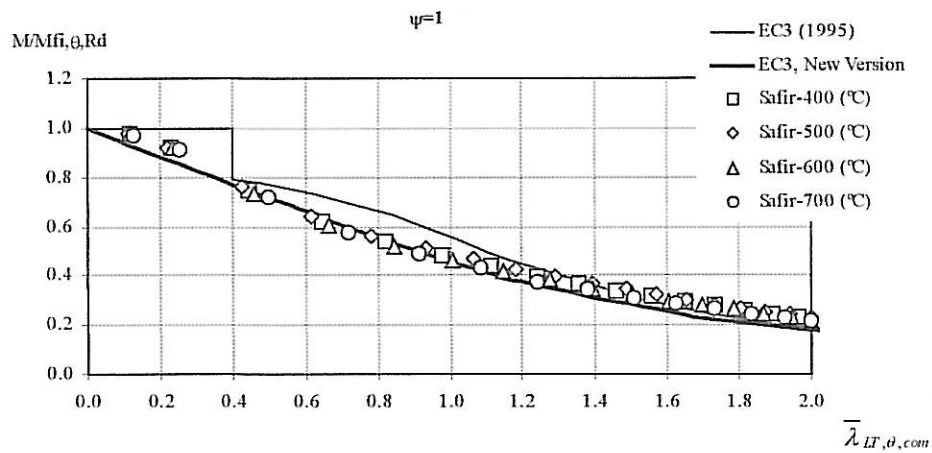

Fig. 4 – Design curves for lateral torsional buckling of beams for $\psi = 1$

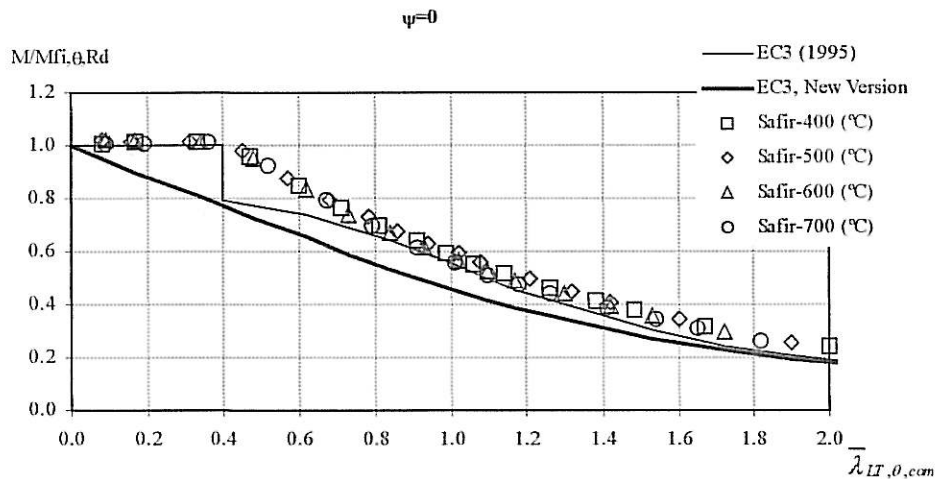

Fig. 5 – Design curves for lateral torsional buckling of beams for $\psi = 0$

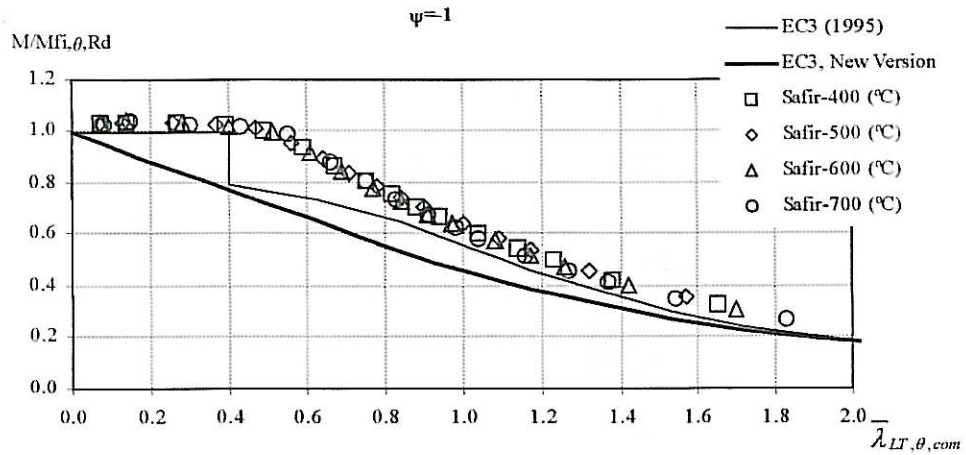

Fig. 6-Design curves for lateral torsional buckling of beams for $\psi = -1$

eurocode design proposal provides perfect fit to the numerical results. As the ψ ratio decreases, the results become too conservative, a direct result of the flexural-torsional buckling safety format of part 1.1 of EC3 [11], that does not account for the effect of bending moment diagram in the calculation of the reduction factor χ_{LT} .

4.2 Beam-Column results: combined major-axis bending and axial force

In order to assess the eurocode design rules for bending and axial force, a parametric study was carried out where the following parameters were considered:

(i) length, L ; (ii) level of axial force, $N/N_{fi,\theta,Rd}$; (iii) level of bending moment, $M/M_{fi,\theta,Rd}$.

For each length L , and for a chosen temperature, the eurocode design expressions (12) and (28) were plotted for increasing ratios of $N/N_{fi,\theta,Rd}$, together with the results of the numerical simulations for that beam-column length. These results are illustrated in figures 8 to 9, for uniform temperature of 600° and for values of ψ ratio equal to -1 , 0 and 1 . In each figure, the continuous surface corresponds to the simple model of Eurocode whereas the cross points result from the numerical simulations, only visible over the surface, i.e. when the simple model is on the safe side. These figures clearly show that there are more points in the safe side for the newer version in case of ψ equal to 1 , and similar safety for the other two cases.

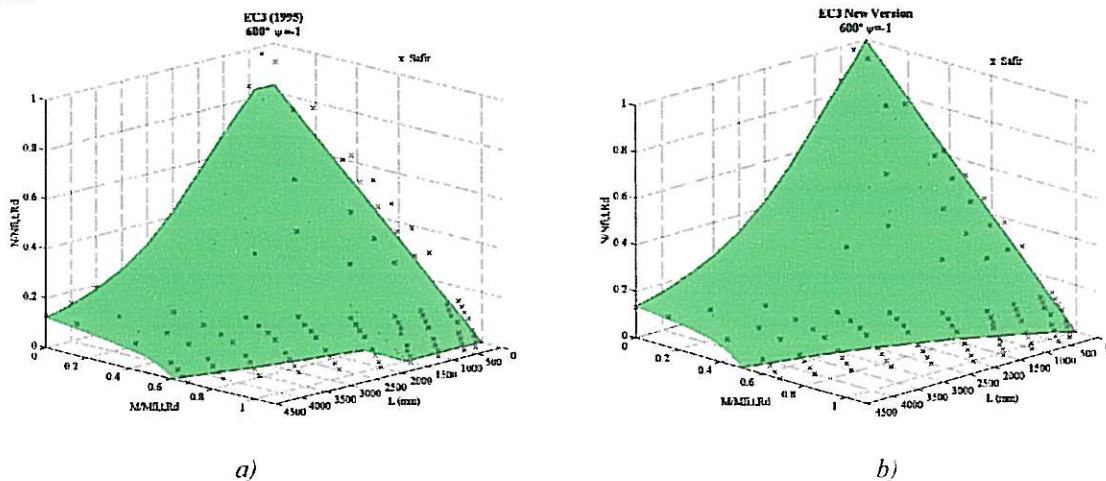

Fig. 8- Interaction surfaces for combined moment and axial load at 600°C . $\psi = -1$
a) Version from 1995; b) New version

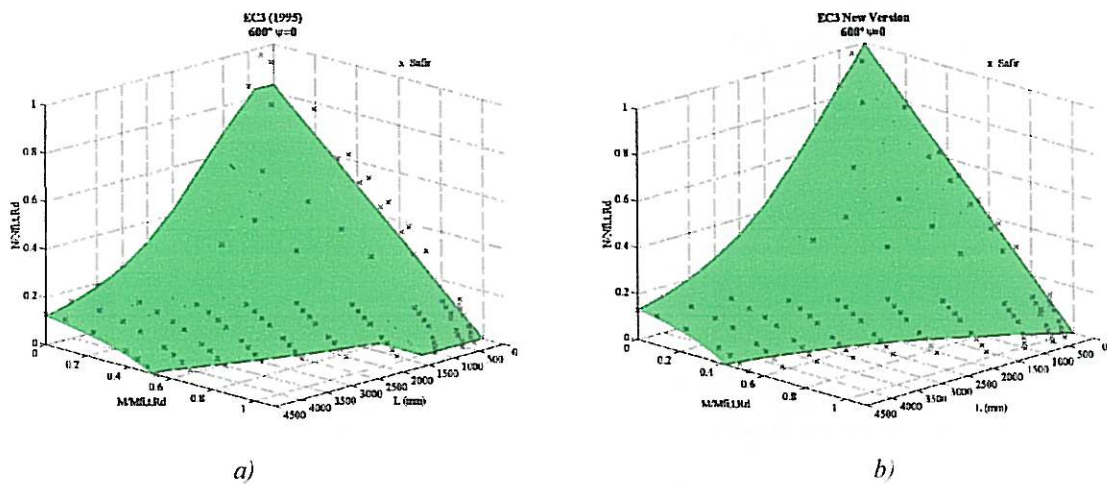

Fig. 9- Interaction surfaces for combined moment and axial load at 600 °C. $\psi = 0$
 a) Version from 1995; b) New version

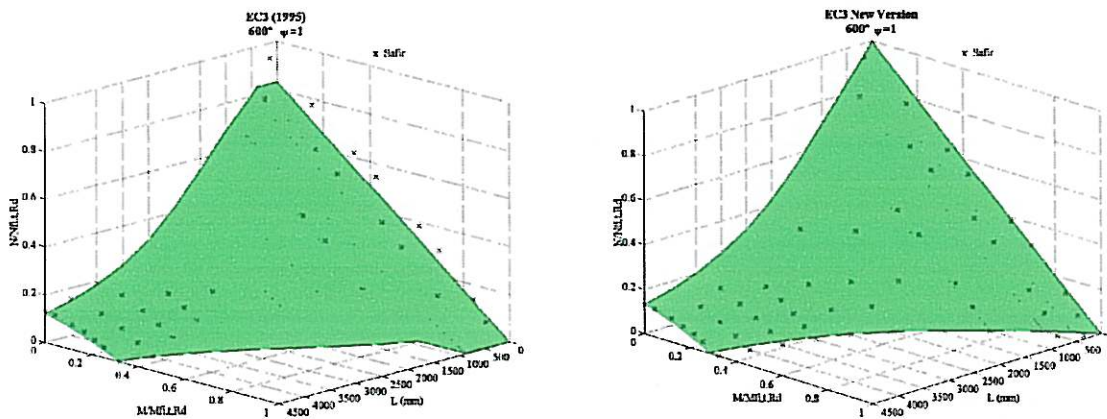

Fig. 10- Interaction surfaces for combined moment and axial load at 600 °C. $\psi = 1$
 a) Version from 1995; b) New version

5. CONCLUSIONS

The comparative analysis performed in this paper has shown that for the beam-column IPE 220 studied and ψ ratio equal to -1 and 0 the two versions of the Eurocode yield similar results in terms of safety. However, for ratio $\psi = 1$, the new version for the fire part of Eurocode is safer than the version from 1995.

This new proposal is general on the safe side when compared to numerical results, as would be expected from a simple calculation model. This is not systematically the case, especially for short members submitted mainly to axial forces. However, it should be mentioned that Franssen et al [2] have calibrated the simple model against experimental tests results in case of a 2D behaviour (no lateral torsional buckling) and have shown that it is very much on the safe side to perform numerical analyses that consider simultaneously a characteristic value for both imperfections, namely the geometrical out of straightness and the residual stresses. It can thus reasonable be expected that the simple model would prove to be on the safe side for the whole (M,N,L) range if compared to experimental tests. Such tests involving 3D

behaviour in elements submitted to axial force and bending moment at elevated temperature have yet to be performed.

8. REFERENCES

1. Franssen, J.-M., Schleich, J.-B. and Cajot L.-G., A Simple Model for Fire Resistance of Axially-loaded Members According to Eurocode 3, *Journal of Constructional Steel Research*, ELSEVIER, 1995, Vol. 35, pp. 49-69.
2. Franssen, J.-M., Schleich, J.-B., Cajot, L.-G., Azpiazu, W., A Simple Model for the Fire Resistance of Axially-loaded Members-Comparison with Experimental Results *Journal of Constructional Steel Research*, ELSEVIER, 1996, Vol. 37, pp. 175-204.
3. Franssen, J. M., Taladona, D., Kruppa, J., Cajot, L.G., Stability of Steel Columns in Case of Fire: Experimental Evaluation, *Journal of Structural Engineering*, 1998, Vol. 124, No. 2, pp. 158-163
4. CEN prEN 1993-1-2, Eurocode 3 – Design of steel structures – part 1-2: General Rules – Structural fire design, February, 2002.
5. Vila Real, P.M.M. and Franssen, J.-M., Lateral buckling of steel I beams under fire conditions - Comparison between the EUROCODE 3 and the SAFIR code, internal report No. 99/02 , Institute of Civil Engineering – Service Ponts et Charpents – of the University of Liege, 1999.
6. Vila Real, P.M.M. and Franssen, J.-M., Numerical Modelling of Lateral Buckling of Steel I Beams Under Fire Conditions – Comparison with Eurocode 3, *Journal of Fire Protection Engineering*, USA, 2001, Vol. 11, No. 2, , pp. 112-128.
7. Vila Real, P.M.M., Piloto, P.A.G. and Franssen, J.-M., A New Proposal of a Simple Model for the Lateral-Torsional Buckling of Unrestrained Steel I-Beams in Case of Fire: Experimental and Numerical Validation, *Journal of Constructional Steel Research*, ELSEVIER, 2003, Vol. 59/2, pp. 179-199.
8. Franssen J.-M., Kodur V. K. R. and Mason J., *User's Manual for SAFIR (Version NZ). A Computer Program for Analysis of Structures Submitted to the Fire*, Univ. of Liege, Ponts et Charpentes, Rapport interne SPEC/2000_03, 2000.
9. ECCS – EUROPEAN CONVENTION FOR CONSTRUCTIONAL STEELWORK, Technical Committee 8 – Structural Stability, Technical Working Group 8.2 – System, “Ultimate Limit State Calculation of Sway Frames With Rigid Joints”, first edition, 1984.
10. CEN ENV 1993-1-2, Eurocode 3 – Design of steel structures – part 1-2: General Rules – Structural fire design, 1995.
11. EUROCODE 3, Design of Steel Structures – part 1-1. General rules and rules for buildings. ENV 1993-1-1, Commission of the European Communities, Brussels, Belgium, 1992.