

# An integrated test bench for research, study or demonstration of variable speed drives of induction motors

H. Teixeira <sup>(1)</sup>, V. Leite <sup>(2)</sup>, J. Batista <sup>(3)</sup>, R. Araújo <sup>(4)</sup>, D. Freitas <sup>(5)</sup>

<sup>(1),(2),(3)</sup> Instituto Politécnico de Bragança - Escola Superior de Tecnologia e de Gestão  
Campus de Sta. Apolónia - Apartado 134, 5301-857 Bragança, Portugal  
Email: <sup>(1)</sup>hteixeira@ipb.pt, <sup>(2)</sup>avtl@ipb.pt, <sup>(3)</sup>jbatista@ipb.pt

<sup>(4),(5)</sup> Faculdade de Engenharia da Universidade do Porto  
Rua Dr. Roberto Frias s/n, 4200-465 Porto, Portugal  
Email: <sup>(4)</sup>raraujo@fe.up.pt, <sup>(5)</sup>dfreitas@fe.up.pt

## Abstract

This paper presents an integrated and low cost test bench for teaching and R&D purposes in variable speed drives of induction motors. The test bench is composed by different integrated sub-systems and the resulting platform is suitable for control, parameter estimation and condition monitoring of induction machines controlled by electrical drives.

**Keywords:** Test bench, induction motor, variable speed drives.

## 1. Introduction

Courses in electric machines and electrical drives are suffering from lack of student interest, all over the world, leading to their cancellation and eventual elimination from the curriculum as referred in [1]. However, the importance of the field of power electronics and electrical drives is patent on the great number of meetings and conferences recently promoted and by the increasing number of publications on this field. The authors of [2] defend that these subjects require a large amount of knowledge regarding power electronics, electric machines, digital control design, digital signal processors, measuring electronics, etc. For this reason, the students are challenged to increase their theoretical knowledge without sufficient details and explanations. Furthermore, the practical experimentation is being more and more reduced. The main goal of the laboratory is to give the possibility to the students to put in practice the theory without spending too much time with details concerning to sophisticated hardware implementations and avoiding high level and expensive development systems like in [2], for instance, to focus only on the monitoring, control and estimation schemes, by using simple and practical solutions as suggested in [3]. This project is intended to be an important contribution to stimulate the student's interest in power electronics, electric machines and variable speed drives as well as to provide them with practical experience in electronic design, and is a contribution to a new philosophy for teaching also suggested in [1] and [3]. The present paper is a new contribution to go beyond the lack of practical experimentation in teaching of power electronics and

electrical drives, providing a test bench that has also been used in research activities related to state, parameter and speed estimation as well as condition monitoring of vector controlled induction machines.

## 2. Description of the test bench prototype

A diagram of the test bench is shown in fig. 1 and consists of five main sub-systems, namely, the power board, the opto-isolation board, the controller board, an electronic unit with several analogue modules for signal processing and several measured and estimated signals monitoring, and the mechanical system that includes an induction motor with an incremental encoder and loaded by a powder brake.

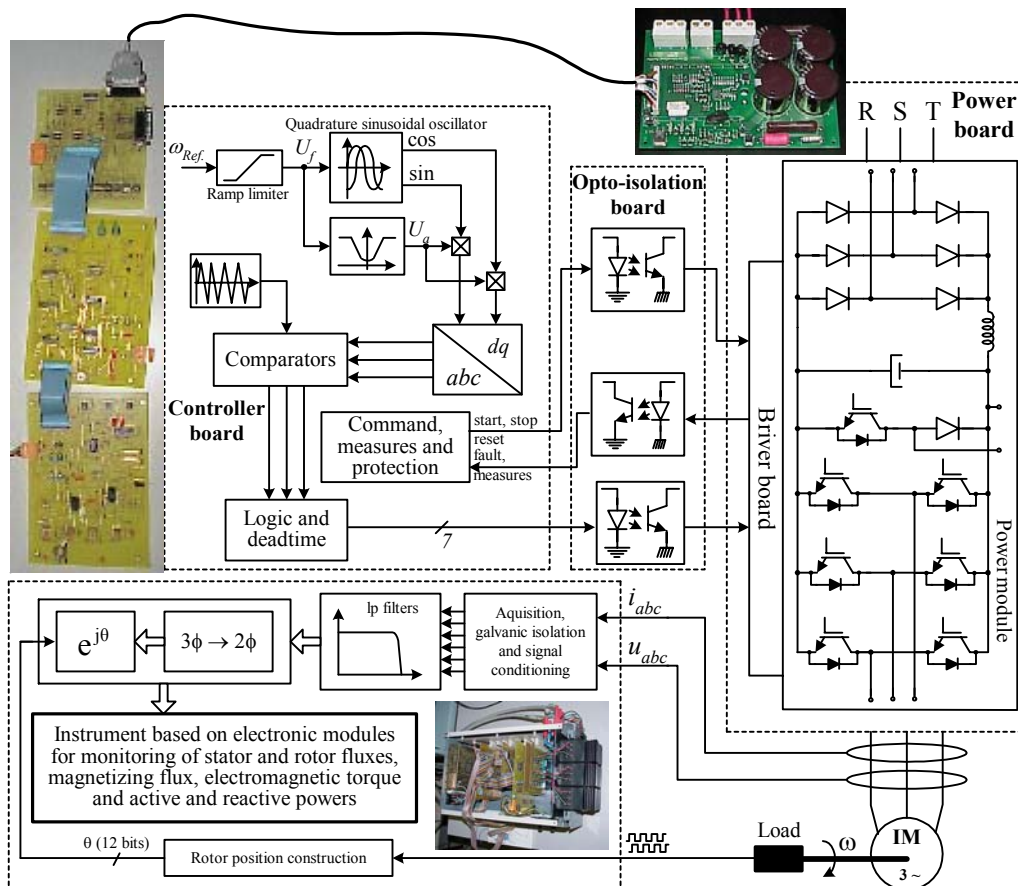

Fig. 1 – General diagram of the test bench prototype.

The power board is based on a low cost commercial and integrated Design Kit, namely, *IRMDAC3*, from the *International Rectifier* company. It is a kit of parts that work together as an evaluation platform for the three phase motor control *IC IR2233* drive and the power module *IRPT2062A* which houses the input rectifier, a break circuit, the output inverter and current sense shunts and a *NTC* thermistor. A driver PCB board receives power from the three phase line and control signals provided by the user's controller board. It supports surge suppression, reduces inrush current and provides DC bus current and voltage feedback as well as fault information. In conjunction with the power module the result is an open, flexible and compact power conversion system with all signals available for monitoring if needed.



of a circuit based on a comparator and an analog switch enabling the inversion of the mechanical speed. Figure 5 shows the three-phase reference system in an inversion of rotation. The signals in both figures 4 and 5 were obtained by means of a data acquisition system.

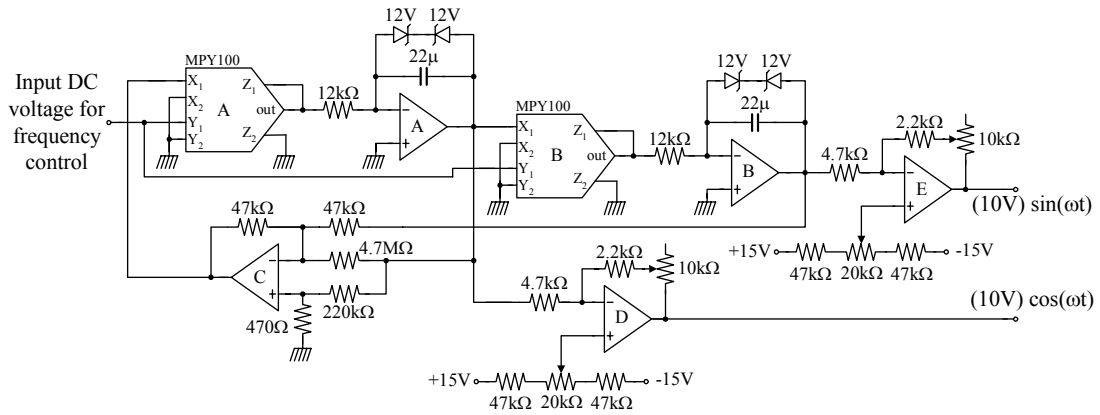

Fig. 3 – Voltage controlled quadrature sinusoidal oscillator.

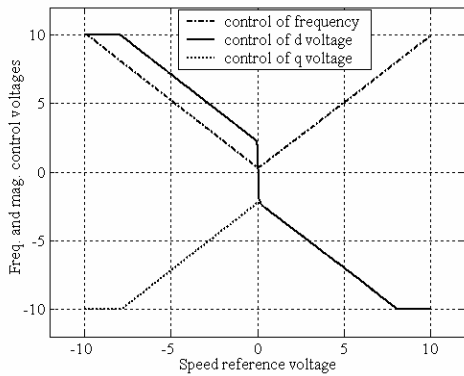

Fig. 4 –DC voltages for frequency and amplitude control of the quadrature sinusoids versus DC input voltage control.

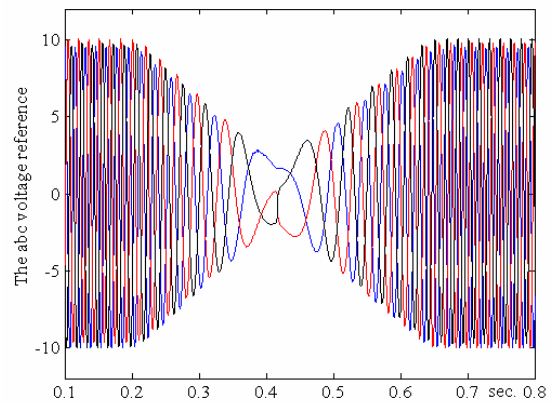

Fig. 5 –The three-phase reference system of voltages in an inversion of rotation.

The implemented voltage controlled quadrature sinusoidal oscillator, shown in fig 3, is based on the two analogue multipliers, *MPY100*, and two integrators implemented with the operational amplifiers A and B and a feedback loop based on operational amplifier C. The frequency varies linearly with the input DC control voltage. From the output of the quadrature oscillator, sine and cosine waves are obtained and can be seen in fig. 6. These two voltages are taken through multipliers where they are multiplied by the respective amplitude control outputs of the circuit in fig. 2 satisfying the V/F law and assuring the minimum voltage at low frequencies. Then, the resulting two-phase reference system, which is shown in fig 7, during an inversion of rotation, is converted into a three-phase sinusoidal voltage reference, by means of a vectorial transformation, and can be seen in fig. 8 together with the triangular carrier. The test bench prototype has been implemented with success in the frequency range of 1Hz to 65Hz. A line-to-line voltage at the inverter output is shown in fig. 9 where the frequency of the fundamental component is about 15Hz. Between the opto-isolation and controller boards there is a command board that implements the dead-time, processes faults detection and measurements as well as the logic signals of command like *stop*, *start* and *reset*.

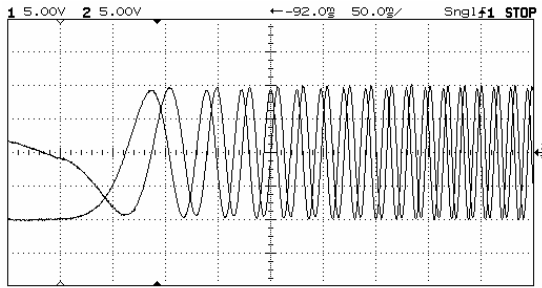

Fig. 6 – The two quadrature sinusoids in an oscillogram before amplitude modulation.

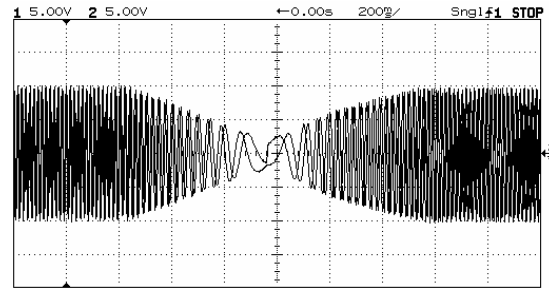

Fig. 7 – The two quadrature sinusoids in an inversion of rotation

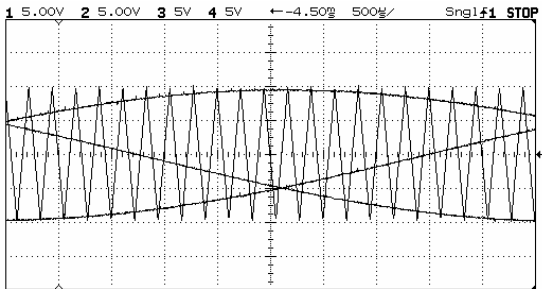

Fig. 8 – The three phase sinusoidal reference and carrier signals.

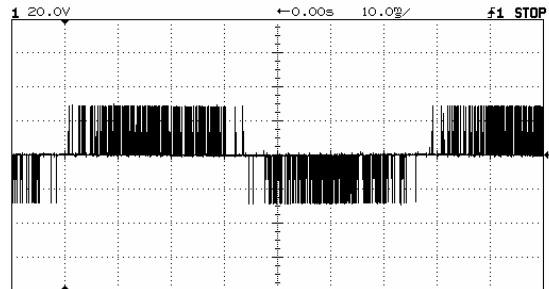

Fig. 9 – The inverter output line-to-line voltage.

The electronic unit has been developed since [4] and is a modular electronic sub-system that has been developed to capture, isolate, filter and process the stator voltages and currents space phasors, as well as to calculate the rotor speed and position, for induction machines controlled by voltage inverters. By using the *AD2S100* analogue vector processor from *Analog Devices*, the equivalent orthogonal *dq* components of stator voltages and currents are available in both stator and rotor reference frames in the range of  $\pm 10V$ , isolated and further filtered by a set of active elliptic low-pass filters, *MAX7411* from *MAXIM*. All signals are available, the three-phase systems of voltages and currents and the equivalent two-phase orthogonal systems, before and after anti-aliasing filtering, as well as before and after coordinate rotation by using the vector processor. Using these available signals, additional electronic modules have been developed and integrated into the previous work [4] as an electronic instrument for real time monitoring of stator, rotor and magnetizing fluxes space phasors, electromagnetic torque and active and reactive powers as described in [5].

The mechanical system includes a 1.5kW squirrel-cage induction motor with nominal characteristics - 400V, 3.2A, 1430 rpm, 50Hz and 2 pole pairs - with an incremental encoder and loaded by a powder brake, both from *Leroy Somer*. The global system has additional electrical machines, a tachometer generator, torque sensors and measurement modules. One of them is used to control the load torque imposed by the powder brake.

#### 4. New developments

Other subsystems are being developed in the scope of students' projects and will be integrated in the test bench, namely, a full-bridge DC-DC converter in order to control a DC machine in all four quadrants and the respective controller board. These electronic circuits will replace the actual mechanical system being an even lower cost solution for a flexible dynamic load while providing the students with additional application-

oriented projects and extending the power electronics design to other topics of the static power conversion and practical design skills.

## 5. Conclusions

The present paper has introduced a low cost and integrated advanced test bench for variable speed drives of induction motors. The developed hardware platform allows the easy assimilation of different concepts and enables the understanding of the enclosed subsystems in order to stimulate the student's interest in power electronics as well as to provide them with practical power electronic design.

A set of new subsystems were successfully integrated in the test bench prototype for control and monitoring purposes in teaching and R&D activities. Some of the subsystems have already been used for online electrical parameters, fluxes and speed estimation of vector controlled induction motors by using advanced techniques based on the extended Kalman filter which in turn requires advanced and consequently expensive development platforms for real time operation. In this case, the ACE kit 1103 has been used for this purpose. With regard to teaching activities the prototype test bench is being successfully used for the following main activities:

- monitoring the voltage and current space phasors in both stator and rotor reference frames, in both Yt and XY modes;
- demonstration of the vector transformation from the three-phase 120 degree into the equivalent two-phase 90 degree sine and cosine signals and their vector rotation into the rotor reference frame which is controlled by the constructed digital rotor angle;
- monitoring the switching pattern of voltage inverters output and analysis of the harmonic content using different cutoff frequencies in the anti-aliasing filters;
- monitoring the stator, rotor and magnetizing fluxes space phasors as well as the electromagnetic torque and both active and reactive powers;
- monitoring the rotor speed and position from an incremental encoder, improving the available resolution from 1024 to 4096 pulses per revolution;
- familiarization with the main important practical aspects related to power electronic design and variable speed drives,
- and finally, the training of the most important practical aspects related to measurement of the electrical and mechanical signals as well as signal conditioning.

## References

- [1] T. Undeland, N. Mohan, *Teaching Electric Machines and Drives: A Re-examination for the New Millennium*, in Proc. EPE-PEMC02, Dubrovnic & Cavtat, Croatia, July 2002, full paper SSTNU01 on CD-ROM.
- [2] R. Teodorescu, M. Bech, A. Jorgensen, K. Larsen, F. Blaabjerk, J. Pedersen, *Advanced Prototyping Tools for Project- and Problem-Based Learning*, in Proc. EPE-PEMC02, Dubrovnic & Cavtat, Croatia, July 2002, full paper SSTNU03 on CD-ROM
- [3] R. Round, *Converter Design for a Model Solar Car*, in Proc. EPE-PEMC02, Dubrovnic & Cavtat, Croatia, July 2002, full paper T12-014 on CD-ROM.
- [4] V. Leite, H. Teixeira, R. Araújo, D. Freitas, *Sistema Electrónico de Condicionamento e Processamento, em Tempo Real, das Tensões e Correntes do Motor de Indução Trifásico Alimentado por Conversores de Frequência*, 7<sup>as</sup> Jornadas Hispano-Lusas de Ingeniería Eléctrica, vol. IV, pp. 111-116, July 2001, Madrid, Spain
- [5] V. Leite, H. Teixeira, F. Casais, R. Araújo, D. Freitas, *A real-time monitoring instrument of induction machines for an integrated teaching test bench*, 8CILEEE, in press, July 2003, Vilamoura, Portugal