Accumulation and release of Pb(II) in aqueous solution by aquatic mosses (*Fontinalis antipyretica*)

Ramiro J.E. Martins

Department of Chemical and Biological Technology,
Polytechnic Institute of Bragança, Campus de Santa Apolónia,
Apartado 1134, 5301-857 Bragança, Portugal
E-mail: rmartins@ipb.pt

Olga M.M. Freitas

Department of Chemical Engineering,
School of Engineering SEP,
Polytechnic Institute of Porto,
Rua Dr. António Bernardino de Almeida,
431, 4200-072 Porto, Portugal
E-mail: omf@fe.up.pt

Vítor J.P. Vilar and Rui A.R. Boaventura*

Laboratory of Separation and Reaction Engineering,
Department of Chemical Engineering, Faculty of Engineering,
University of Porto,
Rua Dr. Roberto Frias, 4200-465 Porto, Portugal
E-mail: vilar@fe.up.pt
E-mail: bventura@fe.up.pt
*Corresponding author

Abstract: The uptake and release of Pb(II) by *Fontinalis antipyretica* was studied in laboratory, by exposing the plants to different lead concentrations for 144 h and 335 h contamination and decontamination periods, respectively. A first order kinetic model was fitted to the experimental data to determine the uptake and release constants, k_1 and k_2 , and other relevant parameters. The metal accumulation capacity, at equilibrium, follows the order: Pb(II) > Zn(II) > Cd(II) > Cr(VI). A Bioconcentration Factor (BCF) and a Biological Elimination Factor (BEF) were also determined; for 0.9–2.2 mg Pb l⁻¹, BCF decreases from about 30748 to 21296.

Keywords: *Fontinalis antipyretica*; first-order model; kinetics; lead.

Reference to this paper should be made as follows: Martins, R.J.E., Freitas, O.M.M., Vilar, V.J.P. and Boaventura, R.A.R. (2012) 'Accumulation and release of Pb(II) in aqueous solution by aquatic mosses (*Fontinalis antipyretica*)', *Int. J. Environment and Waste Management*, Vol. 9, Nos. 3/4, pp.270–283.

Biographical notes: Ramiro J.E. Martins is an Assistant Professor in the Department of Chemical and Biological Technology at the Polytechnic Institute of Bragança, Portugal. He received his graduation in Chemical Engineering from the University of Porto, in 1991, a master degree in Environment Technology from the University of Braga in 1995 and a PhD in Chemical Engineering from University of Porto, in 2004. His research interests are in treatment of heavy metal contaminated waters by biosorption with low cost adsorbents, wastewater treatment by wetlands and environmental engineering. He also acts in the water and wastewater market in a small company (design, management and sales).

Olga M.M. Freitas is an Assistant Professor in the Department of Chemical Engineering at the School of Engineering ISEP, Polytechnic Institute of Porto, Portugal. She is graduated in Chemical Engineering at the Polytechnic Institute of Porto (1996), got a Master Degree (2000) in Environmental Engineering and a PhD in Chemical and Biological Engineering at the University of Porto. The current research interests are the biosorption of micropollutants using low cost materials and wastes valorisation.

Vitor J.P. Vilar received his Graduation in Chemical Engineering from the University of Porto, Portugal, in 2001, a PhD in Chemical Engineering from the same institution in 2006 and a Post-graduation in Environmental Management in 2004. He is currently working as a Post-doc student in water disinfection and wastewater treatment by solar photocatalysis. He has authored more than 20 papers in international scientific periodicals with referees, four papers in edited books, and many others communications in international and national conferences. His specialisation domain is on the treatment of heavy metal contaminated waters by biosorption, and his present research interests are on solar photocatalysis.

Rui A.R. Boaventura is a Principal Investigator in the Department of Chemical Engineering at the University of Porto, Portugal. He received his graduation in Chemical Engineering from the University of Porto, in 1969 and a PhD in the same institution, in 1986. He has over 30 years of experience in teaching, research and consulting in chemical and environmental engineering. His current research interests include colour and heavy metal removal from contaminated waters, formation and fate of disinfection by-products and biogeochemical transformations in surface waters. He has published about 90 papers in peer-reviewed environmental journals and presented over 140 communications in international conferences.

1 Introduction

The biogeochemical cycles of the majority of heavy metals are in constant modification as a consequence of human activities, originating an increasing concentration in water bodies and terrestrial or aquatic ecosystems.

Physical and chemical methods are often applied to reduce the metal pollution levels to achieve discharge limits that comply with the water legislation, but these processes present some limitations. Processes suitable at high concentrations are often either ineffective or cost unreasonable when applied to metal dilute wastewaters (Lodeiro et al., 2005a). Biosorption is an emerging and attractive technology that uses biological

materials to remove metals from solution through adsorption (Volesky, 2003; Norton et al., 2004). Aquatic bryophytes have been referred to in literature as being able to shut off, retain and accumulate pollutants, such as nutrients, toxic organics and heavy metals, leading to a concentration in their tissues several times higher than in the surrounding environment (Nimptsch et al., 2005). Because of their physiological and environmental characteristics and the fact they are widespread in most European rivers (Whitton et al., 1981), aquatic mosses have also been successfully used as biological indicators of surface waters contaminated by heavy metals or radioisotopes (Nimis et al., 2002; Mouvet, 1985; Bruns et al., 1997; Gonçalves and Boaventura, 1998; Vincent et al., 2001). The use of bioaccumulators to monitor water quality is of particular interest for environmental agencies, owing to the difficulties in assessing metal concentrations in the stream water by a purely instrumental approach (Nimis et al., 2002). Their accumulation capacity allows an integration of casual fluctuations in the metal concentration in water during long periods of time. So, aquatic bryophytes proved to be an effective one for the detection of intermittent, sporadic and seasonal pollutant incidents (Gonçalves et al., 1994; Nimis et al., 2002). Srivastav et al. (1994) reported the accumulation capacity of aquatic mosses to remove heavy metals from polluted waters. Moreover, their special characteristics also allow using them as biosorbents to clean industrial wastewaters.

The trace metals are distributed in different compartments of the plant: bound to functional groups on the cell walls, in the cytoplasm, inside the vacuoles and in the form of polymers complexes (Bruns et al., 2001).

To get a correct and effective interpretation of biomonitoring results, several studies have been carried out to establish heavy metal uptake and release kinetics either through laboratory experiments (Gonçalves and Boaventura, 1998; Martins and Boaventura, 2002) or from field surveys (Mersch and Kass, 1994).

Kinetics depends on physical–chemical characteristics of the water, environmental factors (temperature, light intensity, metal concentration and the presence of other compounds) and parameters concerning the plant itself.

In last decades, several authors have studied heavy metal accumulation by bryophytes (Pickering and Puia, 1969; Brown and Beckett, 1985; Gonçalves and Boaventura, 1998; Martins and Boaventura, 2002; Martins, 2004), fungal biomass (Aksu and Balibek, 2006), marine macroalgae (Lodeiro et al., 2005b), agricultural wastes (Kadirvelu et al., 2001, 2003) and biosolids (Norton et al., 2004) to elucidate the uptake or release mechanisms and the uptake rate from metal-enriched solutions.

Foulquier and Hébrard (1976) and Pickering and Puia (1969) suggested that two and three stages, respectively, were identifiable during metal uptake by plant cells in batch system. A simple first-order kinetic model proved to give an adequate approach to the simulation of experimental kinetic data (Martins and Boaventura, 2002; Martins, 2004).

Equilibrium concentrations may be calculated from uptake and release kinetic rate constants, experimentally determined by contaminating the plants during a short period and then exposing them to non-contaminated water (Walker, 1990).

This methodology has been applied to determine BCFs of Cd, Cu, Cr, Ni, Pb and Zn by amphipods (Clason et al., 2003, 2004), Zn by *Gammarus Pulex* (Xu and Pascoe, 1993), and in the investigation on the uptake and release kinetics of Cu (Gonçalves and Boaventura, 1998) and Cd, Cr and Zn (Martins and Boaventura, 2002; Martins, 2004) by *Fontinalis antipyretica*.

Experimental data obtained in laboratory (Srivastav et al., 1994) and from field (Nimis et al., 2002; Hongve et al., 2002) have shown that metal ion uptake by aquatic

mosses depends on the selected species. However, *Fontinalis antipyretica* has been recognised as a good bioindicator for heavy metal contamination (Carballeira and Fernandez, 2002; Bargagli et al., 2002; Figueira and Ribeiro, 2005; Samecka-Cymerman et al., 2005).

This study focused on the lead uptake and release by the aquatic moss *Fontinalis antipyretica*, in the perspective of a future application for decontamination of metal-enriched waters. Actually, many industrial wastewaters have to be decontaminated to comply with permissible discharge limits of about 1.0 mg l^{-1} for lead, and aquatic bryophytes can be used as biosorbent to achieve this limit in a polishing treatment step.

Kinetic and equilibrium parameters were determined by fitting a simple kinetic model to the experimental data.

2 Material and methods

2.1 Mosses

Fontinalis antipyretica was collected from the Selho River, at Aldão, in the Ave River basin. Plant material was taken out from a river stretch without metal contamination upstream, so its metal content is assumed to be of natural origin. Prior to rinsing the mosses directly with river water, dead material, soil particles and invertebrates attached to the plants were removed. Back to the laboratory, the mosses were washed with deionised water and the plant green parts separated to be used later. The material was preserved for some hours in a refrigerator before starting the experimental work.

2.2 Kinetic studies

The experiments were carried out in a continuous flow system, including four 20 L – rectangular basis ($250 \text{ mm} \times 400 \text{ mm}$) and 200 mm height acrylic tanks (Figure 1). Water recirculation by a centrifugal pump (6 l min^{-1}) promotes the agitation and homogenisation, to get perfectly mixed conditions, as confirmed by the analysis of the residence time distribution using the tracer (KCl) technique.

Each tank was supplied from a reservoir containing previously dechlorinated water (by adsorption of residual chlorine onto activated carbon), using peristaltic pumps. The lead stock solution (345.2 mg l^{-1}) was introduced in the feed line of each tank through a multi-channel peristaltic pump. Lead concentrations in the range of $0.9\text{--}2.2 \text{ mg l}^{-1}$, which is common in acid mine drainage waters (Patterson, 1985), were obtained in the tanks. As intermediate concentrations, we expected values of 1.3 and 1.7 mg l^{-1} . For some reason we could not identify, the peristaltic pump P2 delivered a flow rate higher than the expected one. Despite this abnormality, we decided to keep the results from the tank 2. The flow rate was adjusted to 600 ml min^{-1} for all tanks and the water level remained constant. Experiments were carried out at ambient temperature, in the range $17\text{--}20^\circ\text{C}$, and pH was practically constant (7.27 ± 0.03 and 7.43 ± 0.02).

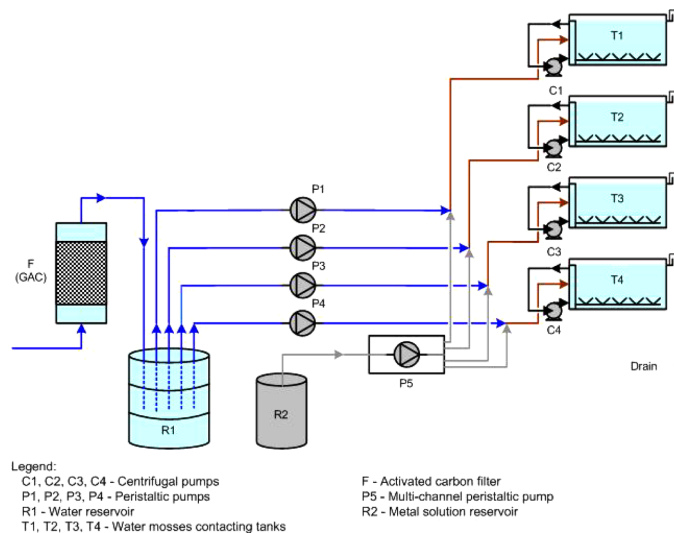
Figure 1 Experimental set-up (see online version for colours)

Illumination was supplied by two fluorescent lamps (a 40 W white light lamp and a 36 W rose light one) that remained switched on during all the experiments. Lamps were about 0.9 m above the water level and the average illumination at the water surface was 1723 Lux.

Moss samples were placed in parallelepiped plastic net bags in amount enough for analyses in duplicate and immersed in each tank. Experiments consisted of a contamination period of 144 h followed by a decontamination stage of 335 h. Mosses and water samples were removed from each tank for analysis, at time intervals previously defined. Biomass remained active during all the experiments as indicated by the oxygen bubbles released, owing to photosynthesis. Although some plant growth could be expected, it was negligible for the contact period within the tanks.

2.3 Analytical procedures

Moss samples from each tank were washed thoroughly with deionised water and dried at 70°C for 24 h. Then, they were ground for 90 s in an ultra-centrifugal mill RETSCH ZM 100 at 1400 rpm. The plant samples were analysed in duplicate after acid digestion. Approximately 100 mg of moss were placed in boxes of teflon (23 ml capacity) previously washed with 10% HNO₃ and then digested with 4 ml of 65% HNO₃. Each box was inserted in a Parr bomb, which was placed in a microwave oven at 600 watts for 60 s. After digestion, the bomb was left to rest for 2 h, being the solution transferred to a 25 ml volumetric flask and diluted with deionised water. Prior to the analysis of lead by atomic absorption spectrometry using acetylene-air flame (AAS, VARIAN SPECTRA, model S220), the solutions were vacuum-filtered through 0.45 µm membranes. The spectral slit width was 1.0 nm and the working current/wavelength was adjusted to 5.0 mA/217.0 nm, giving a detection limit of 1 ppm. The instrument response was periodically checked with Pb²⁺ solution standards. Lead solution (1000 µg ml⁻¹) was obtained from Merck. The lead content in the mosses was expressed in µg g⁻¹ dry weight basis.

3 Kinetic model

For a two-compartments system (water-plant), the metal ions transfer from and to aquatic bryophytes is assumed to be described by a first-order kinetic model (Martins and Boaventura, 2002), represented as:

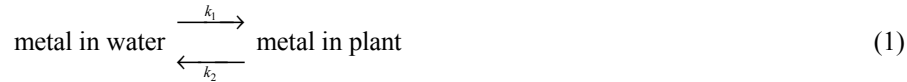

where

- C_W : Metal concentration in the water (mg l^{-1})
- C_m : Metal concentration in the plant ($\mu\text{g g}^{-1}$)
- C_{m0} : Initial metal concentration in the plant ($\mu\text{g g}^{-1}$)
- k_1 : Uptake rate constant (h^{-1})
- k_2 : Release rate constant (h^{-1}).

The metal concentration variation in the plant along the uptake period is given by the differential equation:

$$\frac{dC_m}{dt} = k_1 \frac{C_W}{\rho} - k_2 (C_m - C_{m0}) \quad (2)$$

where $t = \text{time (h)}$ and $\rho = \text{density (kg l}^{-1}\text{)}$.

Integrating equation (2), with the initial condition $C_m = C_{m0}$ at $t = 0$ and assuming $C_W = \text{constant}$, gives:

$$C_m = C_{m0} + \frac{k_1 C_W}{k_2 \rho} (1 - e^{-k_2 t}). \quad (3)$$

When $t \rightarrow \infty$, the metal concentration in the plant tends to equilibrium (C_{me}), then:

$$C_{me} = C_{m0} + \frac{k_1 C_W}{k_2 \rho}. \quad (4)$$

Replacing t by t_d ($t_d = \text{time at the end of uptake period}$) in equation (3), we can calculate the metal concentration at the end of the contamination period (C_{mu}):

$$C_{mu} = C_{m0} + \frac{k_1 C_W}{k_2 \rho} (1 - e^{-k_2 t_d}). \quad (5)$$

At steady-state conditions, the bioaccumulation capacity may be represented by a BCF defined as:

$$\text{BCF} = \frac{(C_{me} - C_{m0})\rho}{C_W} = \frac{k_1}{k_2}. \quad (6)$$

Interrupting the addition of metal to water at $t = t_d$, a decontamination period starts up. Experimental studies have shown that in this period the metal elimination is not

complete, i.e., the metal accumulated tends to be a residual value greater than C_{m0} . In this phase, the metal concentration varies with time according to the equation:

$$\frac{dC_m}{dt} = -k_2(C_m - C_{mr}) \quad (7)$$

where C_{mr} is the residual metal concentration in plant, $\mu\text{g g}^{-1}$.

Integrating equation (7) with the initial condition

$$t = t_d; \quad C_m = C_{mu} \quad (8)$$

it comes:

$$C_m = C_{mr} + (C_{mu} - C_{mr}) \times e^{-k_2(t-t_d)}. \quad (9)$$

As $t \rightarrow \infty$, C_m tends to C_{mr} , and a BEF may be defined for the decontamination period:

$$\text{BEF} = \frac{C_{mu} - C_{mr}}{C_{mu}} = 1 - \frac{C_{mr}}{C_{mu}}. \quad (10)$$

The BEF can take values between zero (no decontamination when mosses are exposed to metal-free water) and one (total metal release).

4 Results and discussion

The physico-chemical characteristics of the free chlorine tap water throughout the experimental work are presented in Table 1. The evolution of the lead concentration in the tanks is plotted in Figure 2. The concentration in the feed stream ranged between 0.9 mg l^{-1} and 2.2 mg l^{-1} . The initial lead concentration in *Fontinalis antipyretica* was $114 \mu\text{g g}^{-1}$, which can be considered as the natural background level for aquatic mosses collected at non-polluted sites (Wehr and Whitton, 1983).

Table 1 Water quality parameters throughout the experiment

Parameter	Range
pH	6.5–7.0
Conductivity ($\mu\text{S cm}^{-1}$)	220–240
Alkalinity ($\text{mg CaCO}_3 \text{ l}^{-1}$)	50.0–58.2
Total hardness ($\text{mg CaCO}_3 \text{ l}^{-1}$)	95.5–106.0
Nitrates (mg l^{-1})	2.3–2.5
Chloride (mg l^{-1})	13.4–13.8
Lead (mg l^{-1})	<0.03
TOC (mg l^{-1})	14.4–14.7

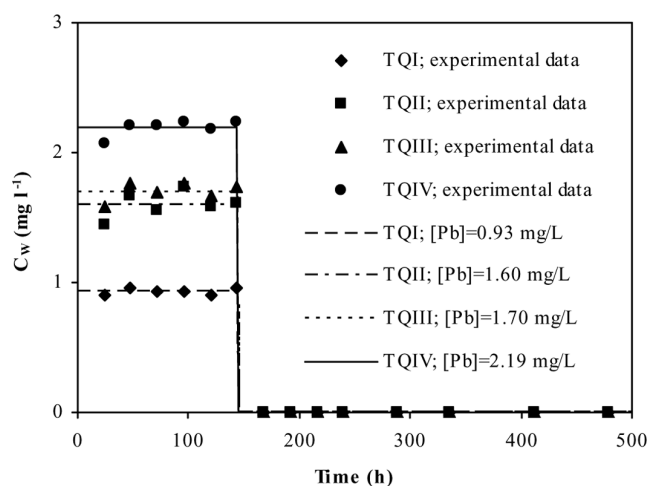
Figure 2 Lead concentration in the tanks throughout the experiment

Equation (3) was fitted to the experimental data for the accumulation stage to determine the uptake and release rate constants. C_{me} (metal concentration at equilibrium) and C_{mu} (metal concentration at the end of the uptake period) values were calculated by equations (4) and (5), respectively. The residual metal concentration, C_{mr} , was obtained by fitting equation (8) to data of the decontamination period. The values of kinetic constants, equilibrium concentrations and statistical parameters, for the uptake and release stages, are presented in Table 2. The evolution of the lead concentration as predicted by the model, as well as the experimental values, is plotted in Figures 3(a)–(d).

Table 2 Kinetic constants and equilibrium concentrations for lead uptake and release

$C_w \pm LC$ 95% (mg l ⁻¹)	$k_1 \pm LC$ 95% (h ⁻¹)	t_{exp}	$k_2 \pm LC$ 95% (h ⁻¹)	t_{exp}	$C_{mr} \pm LC$ 95% (µg g ⁻¹)	t_{exp}
0.93 ± 0.02	507 ± 31	38.3	0.017 ± 0.005	7.3	12247 ± 1355	20.8
1.60 ± 0.08	300 ± 20	35.3	0.012 ± 0.006	5.1	17342 ± 2588	15.8
1.70 ± 0.05	327 ± 19	39.9	0.015 ± 0.005	6.4	17650 ± 1635	24.9
2.19 ± 0.05	298 ± 22	31.2	0.02 ± 0.01	2.5	22812 ± 8134	6.3
	R^2		C_{me} (µg g ⁻¹)		C_{mr}/C_{mu}	
	0.99		28772		0.47	
	0.99		39535		0.53	
	0.99		37183		0.54	
	0.97		46860		0.56	

t ($\alpha = 0.05$; $df = 8$) = 2.306.

Figure 3 Uptake and release of lead by *Fontinalis antipyretica*: (a) metal concentration in the water = 0.93 mg l^{-1} ; (b) 1.60 mg l^{-1} ; (c) 1.70 mg l^{-1} and (d) 2.19 mg l^{-1} ; (— model; ● experimental data)

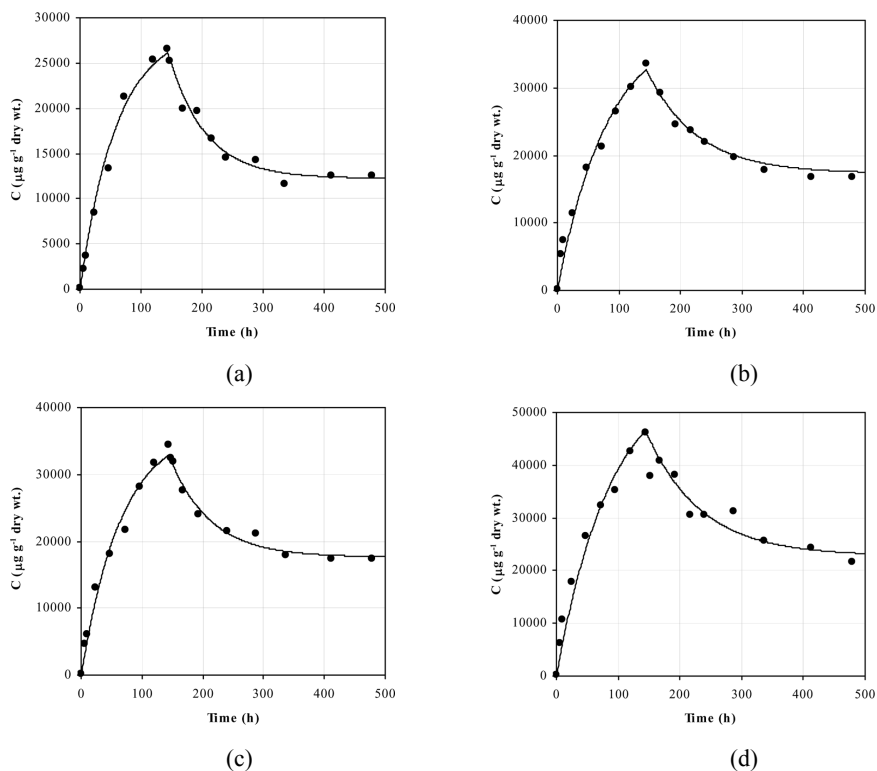

Generically, the mosses accumulate lead in accordance with the external concentration they are exposed to. The kinetic constant k_1 decreased from 507 h^{-1} to 298 h^{-1} as metal concentration increased from 0.93 mg l^{-1} to 2.19 mg l^{-1} . So, for metal concentrations in this range, the retention of metal ions in the cell wall or inside the cell (by complexation with molecules or precipitation inside the vacuoles) probably do not condition the physiological process of the organism, in accordance with those referred by Figueira and Ribeiro (2005), on a study about biomonitoring metals released by a mine effluent.

The plant uptake capacity, expressed as C_{me} or C_{mu} , increases with the metal concentration in water (Table 2). A limit to the amount of metal bound by the mosses seems to exist, as the maximum amount of metal retained by the plant depends on the number of binding sites (Martins and Boaventura, 2002). For the metal concentration used in this work, the maximum uptake capacity was not attained at the end of the contamination period (144 h). Uptake kinetics, however, are not dependent on the number of binding sites, but on lead concentration in water, so the decrease in the kinetic constant k_1 as C_w increases suggests a toxic effect on the plant. For the decontamination phase, k_2 is practically independent of the metal concentration ($k_2 = 0.015 \text{ h}^{-1}$). In the uptake/release kinetic study of Cu(II) by aquatic mosses of the same species, Gonçalves and Boaventura (1998) obtained similar results for the release rate constant. For $C_w \sim 1.0 \text{ mg l}^{-1}$, the release rate constant, k_2 , is greater for Zn(II) than for Pb(II), 0.030 and 0.017 h^{-1} , respectively (Martins and Boaventura, 2002), which means that lead has

a higher affinity to the moss. Such fact can be explained by its higher covalent index (6.61) when compared with zinc (4.07) (Dean, 1999).

As could be expected, at equilibrium, the lead concentration in the plant increases (from 28.8 to 46.8 mg g⁻¹) with the concentration in water. After decontamination, the residual lead concentration in equilibrium with metal-free water is also proportional to the amount accumulated at the end of the uptake period.

Comparing C_{me} values for lead (Table 2) with those obtained for zinc, cadmium and hexavalent chromium by Martins (2004), the uptake equilibrium capacity follows the order Pb(II) > Zn(II) > Cd(II) > Cr(VI). According to Avery and Tobin (1992), the adsorption capacity varies in the direct ratio of the element atomic weight. The functional groups in the cells wall may also be responsible for establishing preferential binding with lead ions (Tyler, 1990).

The metal ions release is very fast in an initial phase, becoming gradually slower, in accordance with a standard described for a concave hyperbole curve (Figure 3). This behaviour may be partially explained by different binding strengths of the metal adsorbed at the surface or more internally into the cells.

Pb(II) uptake increased rapidly in the first hour and then remained nearly constant, suggesting that bioaccumulation is a very fast process. This behaviour is compatible with the mechanism of the uptake in three stages. The first stage (exchange adsorption) corresponds to a rapid surface binding; a large amount of lead is taken up in this stage and it is limited to the Donnan-free-space of the cell wall (Pickering and Puia, 1969). The second stage is slower and the intracellular diffusion (penetration into the protoplast including the cell organelles) governs the process. The slow third stage results from the active accumulation of metal within the plant cells. This stage is dependent on factors that affect the metabolism, such as temperature and light intensity. The experimental results and the first-order kinetic model show that the contribution of the last two stages can be neglected regarding uptake kinetics when compared with the first stage.

The accumulation time was not long enough to reach the saturation of the aquatic mosses with lead. The extent of the decontamination period was adequately established as shown in Figures 3(a)–(d).

BCF and BEF calculated from equations (6) and (10), respectively, are presented in Table 3. BCF values vary inversely with the lead concentration in water, and range between 30748 and 21296. As the metal concentration increases, greater is the driving force, and then active sites with lesser affinity could be occupied. For lower lead concentrations (0.93 mg l⁻¹), the plant can accumulate approximately 31000 times more lead than the concentration in the water. A linear relationship between BCF and C_w was found (Figure 4):

$$\text{BCF} = 37416 - 7538.5 \times C_w; \quad (R^2 = 0.982) \quad \text{for } 0.93 < C_w < 2.19 : \text{mg l}^{-1}.$$

Assuming that the BCF values represent the bioaccumulation potential of a given metal for the moss, a comparative ranking is of great interest. Thus, considering the same metal concentration in water (2.0 mg l⁻¹) and the results of a previous study (Martins, 2004), the BCF values for Pb(II), Zn(II), Cd(II) and Cr(VI) are 22339, 3694, 1903 and 1716, respectively. These values indicate that *Fontinalis antipyretica* can accumulate about 6, 12 and 13 times more lead than zinc, cadmium and chromium, respectively. This is in accordance with the accumulation factors found for *Rhynchostegium*

riparioides ($\text{Pb}^{2+} > \text{Zn}^{2+} > \text{Cd}^{2+} > \text{Cu}^{2+}$) (Wehr and Whitton, 1983) and for *Hylocomium splendens*: ($\text{Cu}^{2+}, \text{Pb}^{2+} > \text{Ni}^{2+} > \text{Co}^{2+} > \text{Zn}^{2+} > \text{Mn}^{2+}$) (Tyler, 1990).

Figure 4 Linear relationship between the Bioconcentration Factor (BCF) and the lead concentration in water (C_w)

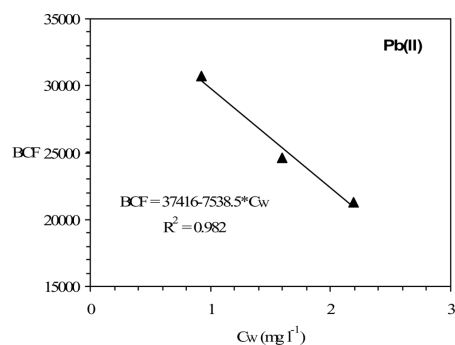

Table 3 Bioconcentration (BCF) and Biological Elimination (BEF) Factors

$C_w \pm LC\ 95\%$ (mg l^{-1})	BCF	BEF
0.93 ± 0.07	30748	0.53
1.60 ± 0.05	24623	0.47
1.70 ± 0.05	21793	0.46
2.19 ± 0.05	21296	0.44

In the decontamination period, lead released by the aquatic mosses reached intermediate values. The BEF remained approximately constant and averaged 0.45. The fraction of lead retained by the plant at equilibrium with metal-free water (C_{mr}/C_{mu}) increases with the maximum accumulated at the end of the uptake period (C_{mu}) as observed in Table 2.

Exposing the aquatic moss *Fontinalis antipyretica* to a $0.75\ \text{mg l}^{-1}$ solution in similar conditions, Gonçalves and Boaventura (1998) obtained a Cu concentration at equilibrium of $22.04\ \text{mg}$ per gram of moss (dry wt.), a value similar to that found in this study using a $0.95\ \text{mg l}^{-1}$ lead solution ($28.4\ \text{mg}$ per gram of moss, dry wt.). This proximity of the C_{me} values for Pb(II) and Cu(II) is due to the compensation of the lesser Cu (II) atomic radius by the greater Pb(II) atomic weight (Avery and Tobin, 1992). The BCFs for lead and copper are 30365 and 29333, respectively, which shows that *Fontinalis antipyretica* has less preference to accumulate lead.

5 Conclusions

Aquatic mosses are able to accumulate lead from aqueous solutions and partially release it when exposed to metal-free water, an interesting particularity that permits the reuse of plant material and partially recover the metal ions.

A first-order kinetic model was successfully fitted to the experimental data of lead uptake/release by *Fontinalis antipyretica*. Both phases are suitably described for this model, then permitting to know the kinetic constants and equilibrium concentrations.

When the lead concentration in water increases, a decrease in the metal uptake rate was observed. This fact imputes a toxic effect in plants and a subsequent deterioration of their physiological state.

For lead concentrations in the range of 0.93–2.19 mg l⁻¹, *Fontinalis antipyretica* accumulates, at equilibrium, the metal ion by a factor of 30748–21296 (Pb concentration in the moss, µg g⁻¹, dry wt.).

After exposition of contaminated mosses to lead-free water, the plants retain between 47% and 66% of the metal previously accumulated.

Comparing Pb (covalent binding) and Zn (electrostatic binding) accumulation and release by the same moss species, it was observed that, for similar concentrations in water, Zn uptake is slower and the amount retained in the plant is lower.

Fontinalis antipyretica may be used in the decontamination of industrial effluents, as well as in monitoring aquatic systems where lead is present as pollutant.

Acknowledgement

The authors wish to thank FCT (Portuguese Foundation for Science and Technology) for the financial support under the research project POCTI/C/EQU/12139/98.

References

- Aksu, Z. and Balibek, E. (2006) 'Chromium(VI) biosorption by dried *Rhizopus arrhizus*: effect of salt (NaCl) concentration on equilibrium and kinetic parameters', *J. Hazard. Mat.*, Vol. 145, pp.210–220.
- Avery, S. and Tobin, J. (1992) 'Mechanisms of strontium uptake by laboratory and brewing strains of *Saccharomyces cerevisiae*', *Appl. Environ. Microbiol.*, Vol. 58, pp.3883–3889.
- Bargagli, R., Monaci, F., Borghini, F., Bravi, F. and Agnorelli, C. (2002) 'Mosses and lichens as biomonitors of trace metals. A comparison study on *Hypnum cupressiforme* and *Parmelia caperata* in a former mining district in Italy', *Environ. Pollut.*, Vol. 116, pp.279–287.
- Brown, D.H. and Beckett, R.P. (1985) 'Intracellular and extracellular uptake of cadmium by the moss *Rhytidiadelphus squarrosus*', *Ann. Bot.*, Vol. 55, pp.179–188.
- Bruns, I., Friese, K., Markert, B. and Krauss, G.-J. (1997) 'The use of *Fontinalis antipyretica* L. ex. Hedw. as a bioindicator for heavy metals. 2. Heavy metal accumulation and physiological reaction of *Fontinalis antipyretica* L. ex. Hedw. in active biomonitoring in the river Elbe', *Sci. Total Environ.*, Vol. 204, pp.161–176.
- Bruns, I., Sutter, K., Menge, S. and Neumann, D. (2001) 'Cadmium lets increase the glutathione pool in bryophytes', *J. Plant Physiol.*, Vol. 158, pp.79–89.
- Carballeira, A. and Fernandez, J.A. (2002) 'Bioconcentration of metals in the moss *Scleropodium purum* in the area surrounding a power plant: a geotopographical predictive model for mercury', *Chemosphere*, Vol. 47, pp.1041–1048.
- Clason, B., Duquesne, S., Liess, M., Schulz, R. and Zauke, G.P. (2003) 'Bioaccumulation of trace metals in the Antarctic amphipod *Paramoera walkeri* (Stebbing, 1906): comparison of two-compartment and hyperbolic toxicokinetic models', *Aquat. Toxicol.*, Vol. 65, pp.117–140.
- Clason, B., Gulliksen, B. and Zauke, G.P. (2004) 'Assessment of two-compartment models as predictive tools for the bioaccumulation of trace metals in the amphipod *Gammarus oceanicus* Segerstrale, 1947 from Grunnfjord (Northern Norway)', *Sci. Total Environ.*, Vol. 323, pp.227–241.
- Dean, J.A. (1999) *Lange's Handbook of Chemistry*, McGraw-Hill, New York.

- Figueira, R. and Ribeiro, T. (2005) 'Transplants of aquatic mosses as biomonitors of metals released by a mine effluent', *Environ. Pollut.*, Vol. 136, pp.293–301.
- Foulquier, L. and Hébrard, J.P. (1976) 'Étude expérimentale de la fixation et de la décontamination du sodium 22 par une mousse *dulcaciquole* *Platyhypnydium riparioides* (Hedw.) Dix', *Oecol. Plantarum*, Vol. 11, pp.267–276.
- Gonçalves, E.P.R. and Boaventura, R.A.R. (1998) 'Uptake and release kinetics of copper by the aquatic moss *Fontinalis antipyretica*', *Water Res.*, Vol. 32, pp.1305–1313.
- Gonçalves, E.P.R., Soares, H.M.V.M., Boaventura, R.A.R., Machado, A.A.S.C. and Silva, J.C.G.E. (1994) 'Seasonal variations of heavy metals in sediments and aquatic mosses from the Cávado river basin (Portugal)', *Sci. Total Environ.*, Vol. 142, pp.143–156.
- Hongve, D., Brittain, J.E. and Bjornstad, H.E. (2002) 'Aquatic mosses as a monitoring tool for ¹³⁷Cs contamination in streams and rivers – a field study from central southern Norway', *J. Environ. Radioact.*, Vol. 60, pp.139–147.
- Kadirvelu, K., Thamaraiselvi, K. and Namasivayam, C. (2001) 'Removal of heavy metals from industrial wastewaters by adsorption onto activated carbon prepared from an agricultural solid waste', *Biores. Technol.*, Vol. 76, pp.63–65.
- Kadirvelu, K., Kavipriya, M., Karthika, C., Radhika, M., Vennilamani, N. and Pattabhi, S. (2003) 'Utilization of various agricultural wastes for activated carbon preparation and application for the removal of dyes and metal ions from aqueous solutions', *Biores. Technol.*, Vol. 87, pp.129–132.
- Lodeiro, P., Cordero, B., Barriada J.L., Herrero, R. and Sastre de Vicente, M.E. (2005a) 'Biosorption of cadmium by biomass of brown marine macroalgae', *Biores. Technol.*, Vol. 96, pp.1796–1803.
- Lodeiro, P., Rey-Castro, C., Barriada, J.L., Sastre de Vicente, M.E. and Herrero, R. (2005b) 'Biosorption of cadmium by the protonated macroalga *Sargassum muticum*: binding analysis with a nonideal, competitive, and thermodynamically consistent adsorption (NICCA) model', *J. Colloid Interface Sci.*, Vol. 289, pp.352–358.
- Martins, R.J.E. (2004) *Acumulação e libertação de metais pesados por briófitas aquáticas*, PhD Thesis, *Faculdade de Engenharia*, Universidade do Porto, Porto.
- Martins, R.J.E. and Boaventura, R.A.R. (2002) 'Uptake and release of zinc by aquatic bryophytes (*Fontinalis antipyretica* L. ex. Hedw.)', *Water Res.*, Vol. 36, pp.5005–5012.
- Mersch, J. and Kass, M. (1994) 'La mousse aquatique *Fontinalis antipyretica* comme traceur de la contamination radioactive de la Moselle en aval de la Centrale nucléaire de Cattenom', *Bull. Soc. Natural. Luxemb.*, Vol. 95, pp.109–117.
- Mouvet, C. (1985) 'The use of aquatic bryophytes to monitor heavy metal pollution of freshwaters as illustrated by case studies', *Int. Ver. Theor. Angew. Limnol. Verh.*, Vol. 22, pp.2420–2425.
- Nimis, P.L., Fumagalli, F., Bizzotto, A., Codogno, M. and Skert, N. (2002) 'Bryophytes as indicators of trace metal pollution in the River Brenta (NE Italy)', *Sci. Total Environ.*, Vol. 286, pp.233–242.
- Nimptsch, J., Wunderlin, D.A., Dollan, A. and Pflugmacher, S. (2005) 'Antioxidant and biotransformation enzymes in *Myriophyllum quitense* as biomarkers of heavy metal exposure and eutrophication in Suquia River basin (Córdoba, Argentina)', *Chemosphere*, Vol. 261, pp.147–157.
- Norton, L., Baskaran, K. and McKenzie, T. (2004) 'Biosorption of zinc from aqueous solutions using biosolids', *Adv. Environ. Res.*, Vol. 8, pp.629–635.
- Patterson, J.W. (1985) *Industrial Wastewater Treatment Technology*, Butterworth, Boston.
- Pickering, D.C. and Puia, I.L. (1969) 'Mechanism for the uptake of zinc by *Fontinalis antipyretica*', *Physiology*, Vol. 22, pp.653–661.
- Samecka-Cymerman, A., Kolon, K. and Kempers, A.J. (2005) 'A comparison of native and transplanted *Fontinalis antipyretica* Hedw. as biomonitors of water polluted with heavy metals', *Sci. Total Environ.*, Vol. 341, pp.97–107.

- Srivastav, R.K., Gupta, S.K., Nigam, K.D.P. and Vasudevan, P. (1994) 'Treatment of chromium and nickel in wastewater by using aquatic plants', *Water Res.*, Vol. 28, pp.1631–1638.
- Tyler, G. (1990) 'Bryophytes and heavy metals: a literature review', *Bot. J. Limnol. Soc.*, Vol. 104, pp.231–253.
- Vincent, C.D., Lawlor, A.J. and Tipping, E. (2001) 'Accumulation of Al, Mn, Fe, Cu, Zn, Cd and Pb by the bryophyte *Scapania undulata* in three upland waters of different pH', *Environ. Pollu.*, Vol. 114, pp.93–100.
- Volesky, B. (2003) *Sorption and Biosorption*, Quebec, BV Sorbex, Inc.
- Walker, C.H. (1990) 'Kinetic models to predict bioaccumulation of pollutants', *Funct. Ecol.*, Vol. 4, pp.295–301.
- Wehr, J.D. and Whitton, B.A. (1983) 'Accumulation of heavy metals by aquatic mosses', *2.Rhynchosygium riparioides. Hydrobiologia*, Vol. 100, pp.261–284.
- Whitton, B.A., Say, P.P. and Wehr, J.D. (1981) 'Use of plants to monitor heavy metals in rivers', in Whitton, B.A. (Ed.): *Heavy Metals in Northern England: Environmental and Biological Aspects*, Univ. of Durham, England, pp.125–145.
- Xu, Q. and Pascoe, D. (1993) 'The bioconcentration of zinc by *Gammarus pulex* (L.) and the application of a kinetic model to determine bioconcentration factors', *Water Res.*, Vol. 27, pp.1683–1688.

Nomenclature

BCF	Bioconcentration Factor
BEF	Biological Elimination Factor
C_m	Metal concentration in the plant ($\mu\text{g g}^{-1}$)
C_{m0}	Initial metal concentration in the plant ($\mu\text{g g}^{-1}$)
C_{mr}	Residual metal concentration in the plant ($\mu\text{g g}^{-1}$)
C_{mu}	Metal concentration in the plant at the end of uptake period ($\mu\text{g g}^{-1}$)
C_w	Metal concentration in the water (mg l^{-1})
k_1	Uptake rate constant (h^{-1})
k_2	Release rate constant (h^{-1})
t_d	Time at the end of uptake period (h)
ρ	Water density (kg l^{-1})
